

MSP430FR21xx, MSP430FR2000 混合信号微控制器

1 器件概述

1.1 特性

- 嵌入式微控制器
 - 16 位精简指令集计算机 (RISC) 架构, 高达 16MHz
 - 3.6V 至 1.8V 的宽电源电压范围 (最低电源电压受限于 SVS 电平, 请参阅 [SVS 规格](#))
- 经优化的低功耗模式 (3V 时)
 - 工作模式: 120 μ A/MHz
 - 待机
 - LPM3.5 (采用低功耗振荡器 (VLO)): 1 μ A
 - 实时时钟 (RTC) 计数器 (LPM3.5, 采用 32768Hz 晶振): 1 μ A
 - 关断 (LPM4.5): 34nA, 无 SVS
- 高性能模拟
 - 8 通道 10 位模数转换器 (ADC)
 - 集成温度传感器
 - 1.5V 内部基准电压
 - 采样与保持 200kpsps
 - 增强型比较器 (eCOMP)
 - 集成 6 位数模转换器 (DAC) 作为基准电压
 - 可编程迟滞
 - 可配置的高功率和低功率模式
- 低功耗铁电 RAM (FRAM)
 - 高达 3.75KB 的非易失性存储器
 - 内置错误修正码 (ECC)
 - 可配置的写保护
 - 对程序和常量数据统一进行存储
 - 10¹⁵ 写入周期持久性
 - 抗辐射和非磁性
- 智能数字外设
 - 一个具有 3 个捕捉/比较寄存器的 16 位定时器 (Timer_B3)
 - 一个仅用作定时器的 16 位 RTC 定时器
 - 16 位循环冗余校验器 (CRC)
- 增强型串行通信
 - 增强型 USCI A (eUSCI_A) 支持通用异步收发器 (UART)、红外数据通讯 (IrDA) 和串行外设接口 (SPI)
- 时钟系统 (CS)
 - 片上 32kHz RC 振荡器 (REFO)
 - 带有锁频环 (FLL) 的片上 16MHz 数字控制振荡器 (DCO)
 - 室温下的精度为 $\pm 1\%$ (具有片上基准)
 - 片上超低频 10kHz 振荡器 (VLO)
 - 片上高频调制振荡器 (MODOSC)
 - 32kHz 外部晶振 (LFXT)
 - 可编程 MCLK 预分频器 (1 至 128)
 - 通过可编程的预分频器 (1、2、4 或 8) 从 MCLK 获得的 SMCLK
- 通用输入/输出和引脚功能
 - 12 个 I/O (采用 16 引脚封装)
 - 8 个中断引脚 (4 个引脚用于 P1, 4 个引脚用于 P2) 可将 MCU 从 LPM 模式下唤醒
 - 所有 I/O 均为电容式触控 I/O
- 开发与软件 (另请参阅 [工具与软件](#))
 - 免费的专业开发环境
 - 开发套件 (MSP-TS430PW20、MSP-FET430U20、MSP-EXP430FR2311 和 MSP-EXP430FR4133)
- 系列成员 (另请参阅 [器件比较](#))
 - MSP430FR2111: 3.75KB 程序 FRAM + 1KB RAM
 - MSP430FR2110: 2KB 程序 FRAM + 1KB RAM
 - MSP430FR2100: 1KB 程序 FRAM + 512 字节 RAM
 - MSP430FR2000: 0.5KB 程序 FRAM + 512 字节 RAM
- 封装选项
 - 16 引脚: TSSOP (PW16)
 - 24 引脚: VQFN (RLL)
- 有关完整模块说明, 请参见 [《MSP430FR4xx 和 MSP430FR2xx 系列器件用户指南》](#)

1.2 应用

- 电器电池组中
- 烟雾和热量探测器
- 门窗传感器
- 照明传感器
- 电源监控
- 便携式个人护理电子仪器
- 健康与健身设备



1.3 说明

MSP430FR2000 和 MSP430FR21xx 器件是 MSP430™ 微控制器 (MCU) 超值系列传感产品组合的一部分。这款超低功耗, 低成本的 MCU 系列提供从 0.5KB 至 4KB 内存大小的 FRAM 统一存储器, 并具有多种封装选项, 包括 3mmx3mm 的小型 VQFN 封装。该架构、FRAM 和集成外设与多种低功耗模式相结合, 针对在便携式和电池供电传感应用中实现延长电池寿命进行了优化。灵活 PMIC。MSP430FR2000 和 MSP430FR21xx 器件为 8 位设计提供了一个迁移路径, 以从外设集成以及 FRAM 的数据记录和低功耗优势获得附加特性和功能。此外, 使用 MSP430G2x 系列 MCU 可将现有设计迁移到 MSP430FR2000 和 MSP430F21xx 系列, 以提高性能并利用 FRAM 的优点。

MSP430FR2000 和 MSP430FR21xx 系列 MCU 具有功能强大的 16 位 RISC CPU、16 位寄存器和一个有助于获得最大编码效率的常数发生器。数字控制振荡器 (DCO) 通常还可以让器件在不到 10 μ s 的时间内从低功耗模式唤醒至激活模式。此 MCU 的功能集可满足从电器电池组和电池监控到烟雾探测器和健身器材等应用的需求。

MSP 超低功耗 (ULP) FRAM 微控制器平台将独特的嵌入式 FRAM 和全面的超低功耗系统架构相结合, 从而使系统设计人员在低能耗条件下提升性能。FRAM 技术将 RAM 的低能耗快速写入、灵活性和耐用性与闪存的非易失性相结合。

MSP430FR2000 和 MSP430FR21x 系列 MCU 由一款广泛的硬件和软件生态系统进行支持, 提供参考设计和代码示例, 协助用户快速开展设计。开发套件包括 MSP-EXP430FR2311 和 MSP430FR4133 LaunchPad™ 开发套件和 MSP-TS430PW20 20 引脚目标开发板。TI 还提供免费 MSP430Ware™ 软件, 可作为 Code Composer Studio™ IDE 台式机和云版本 (位于 TI Resource Explorer) 的组件。MSP430 MCU 还通过 E2E™ 社区论坛提供广泛的在线配套资料、培训和在线支持。

器件信息⁽¹⁾

器件型号	封装	封装尺寸 ⁽²⁾
MSP430FR2111IPW16	TSSOP (16)	5mm x 4.4mm
MSP430FR2110IPW16		
MSP430FR2100IPW16		
MSP430FR2000IPW16		
MSP430FR2111IRLL	VQFN (24)	3mm x 3mm
MSP430FR2110IRLL		
MSP430FR2100IRLL		
MSP430FR2000IRLL		

(1) 要获得最新的产品、封装和订购信息, 请参见封装选项附录 (节 9), 或者访问德州仪器 (TI) 网站 www.ti.com.cn。

(2) 这里显示的尺寸为近似值。要获得包含误差值的封装尺寸, 请参见机械数据 (节 9 中)。

CAUTION

系统级静电放电 (ESD) 保护必须符合器件级 ESD 规范, 以防发生电气过载或对数据或代码存储器造成干扰。更多相关信息, 请参见 《MSP430™ 系统级 ESD 注意事项》。

1.4 功能框图

图 1-1 给出了功能框图。

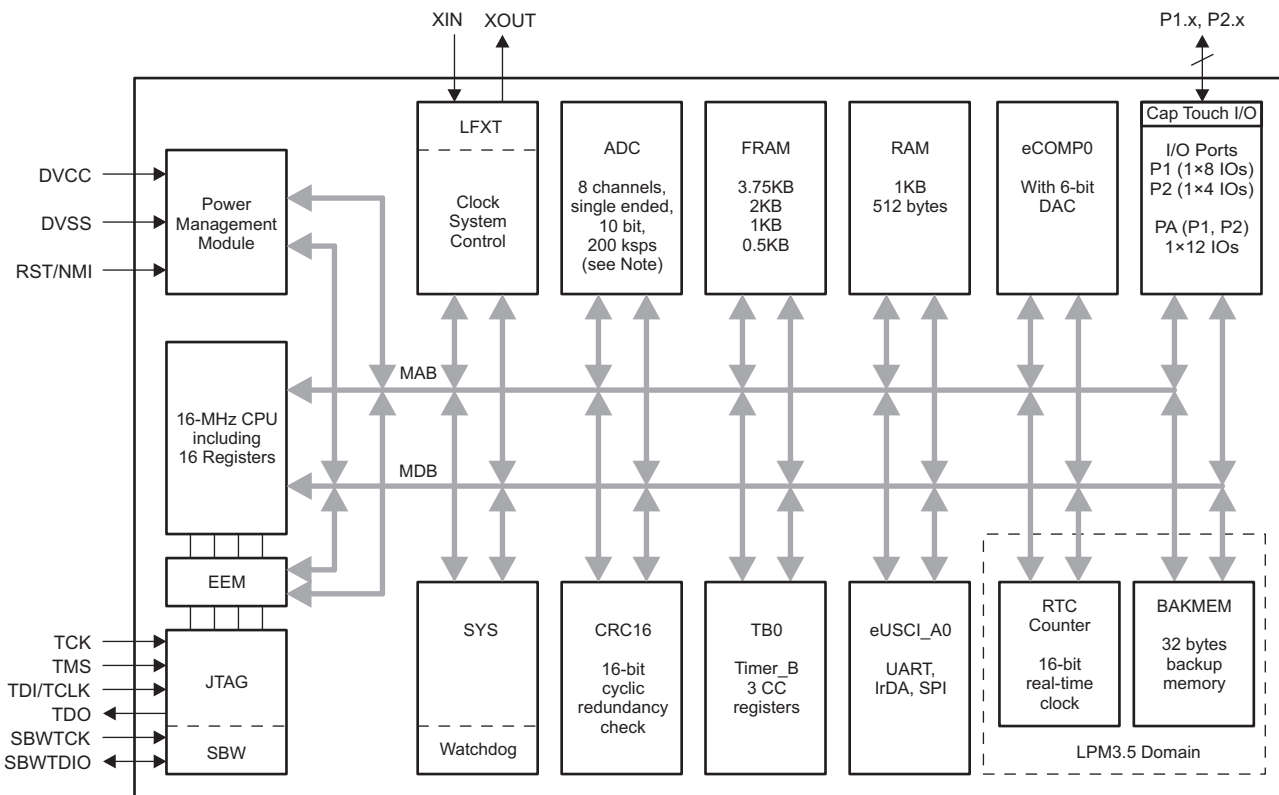

Copyright © 2017, Texas Instruments Incorporated

NOTE: ADC 在 MSP430FR2000 器件上不可用。

图 1-1. 功能框图

- 该器件具有一对主电源（DVCC 和 DVSS），分别为数字和模拟模块供电。推荐的旁路电容和去耦电容分别为 4.7μF 至 10μF 和 0.1μF，精度为 ±5%。
- P1 的 4 个引脚和 P2 的 4 个引脚均具备引脚中断功能，可将 MCU 从所有低功耗模式（LPM）唤醒（包括 LPM4、LPM3.5 和 LPM4.5）。
- Timer_B3 具有三个捕捉/比较寄存器。仅 CCR1 和 CCR2 从外部连接。CCR0 寄存器仅用于内部周期时序和中断生成。
- 在 LPM3.5 模式下，RTC 计数器与备用存储器可继续工作，而其余外设停止工作。
- 所有通用 I/O 均可配置为电容式触控 I/O。

内容

1	器件概述	1	5.13	Timing and Switching Characteristics	17
1.1	特性	1	6	Detailed Description	35
1.2	应用	1	6.1	Overview	35
1.3	说明	2	6.2	CPU	35
1.4	功能框图	3	6.3	Operating Modes	35
2	修订历史记录	5	6.4	Interrupt Vector Addresses	37
3	Device Comparison	6	6.5	Memory Organization	38
3.1	Related Products	6	6.6	Bootloader (BSL)	38
4	Terminal Configuration and Functions	7	6.7	JTAG Standard Interface	38
4.1	Pin Diagrams	7	6.8	Spy-Bi-Wire Interface (SBW)	39
4.2	Pin Attributes	8	6.9	FRAM	39
4.3	Signal Descriptions	10	6.10	Memory Protection	39
4.4	Pin Multiplexing	12	6.11	Peripherals	39
4.5	Connection of Unused Pins	12	6.12	Device Descriptors (TLV)	57
4.6	Buffer Type	12	6.13	Identification	58
5	Specifications	13	7	Applications, Implementation, and Layout	59
5.1	Absolute Maximum Ratings	13	7.1	Device Connection and Layout Fundamentals	59
5.2	ESD Ratings	13	7.2	Peripheral- and Interface-Specific Design Information	62
5.3	Recommended Operating Conditions	13	7.3	Typical Applications	63
5.4	Active Mode Supply Current Into V_{CC} Excluding External Current	14	8	器件和文档支持	64
5.5	Active Mode Supply Current Per MHz	14	8.1	入门和后续步骤	64
5.6	Low-Power Mode LPM0 Supply Currents Into V_{CC} Excluding External Current	14	8.2	器件命名规则	64
5.7	Low-Power Mode LPM3, LPM4 Supply Currents (Into V_{CC}) Excluding External Current	15	8.3	工具与软件	65
5.8	Typical Characteristics – LPM3 Supply Currents	15	8.4	文档支持	67
5.9	Low-Power Mode LPMx.5 Supply Currents (Into V_{CC}) Excluding External Current	16	8.5	相关链接	68
5.10	Typical Characteristics – LPMx.5 Supply Currents	16	8.6	社区资源	68
5.11	Typical Characteristics - Current Consumption Per Module	16	8.7	商标	68
5.12	Thermal Resistance Characteristics	17	8.8	静电放电警告	68
			8.9	术语表	68
			9	机械、封装和可订购信息	69

2 修订历史记录

Changes from July 15, 2017 to August 28, 2018	Page
• Added note to V_{SVSH-} and V_{SVSH+} parameters in Table 5-1 , <i>PMM, SVS and BOR</i>	17
• Added the note "Controlled by the RTCKSEL bit in the SYSCFG2 register" on Table 6-7 , <i>Clock Distribution</i>	40
• Changed 1 μ F capacitor to 10 μ F in Figure 7-1 , <i>Power Supply Decoupling</i>	59
• 更新了节 8.2 器件命名规则 中的文本和图	64

3 Device Comparison

Table 3-1 summarizes the features of the available family members.

Table 3-1. Device Comparison⁽¹⁾ ⁽²⁾

DEVICE	PROGRAM FRAM (Kbytes)	SRAM (Bytes)	TB0	eUSCI_A	10-BIT ADC CHANNELS	eCOMP0	I/O	PACKAGE
MSP430FR2111IPW16	3.75	1024	3 × CCR ⁽³⁾	1	8	1	12	16 PW (TSSOP)
MSP430FR2110IPW16	2	1024	3 × CCR ⁽³⁾	1	8	1	12	16 PW (TSSOP)
MSP430FR2100IPW16	1	512	3 × CCR ⁽³⁾	1	8	1	12	16 PW (TSSOP)
MSP430FR2000IPW16	0.5	512	3 × CCR ⁽³⁾	1	–	1	12	16 PW (TSSOP)
MSP430FR2111IRLL	3.75	1024	3 × CCR ⁽³⁾	1	8	1	12	24 RLL (VQFN)
MSP430FR2110IRLL	2	1024	3 × CCR ⁽³⁾	1	8	1	12	24 RLL (VQFN)
MSP430FR2100IRLL	1	512	3 × CCR ⁽³⁾	1	8	1	12	24 RLL (VQFN)
MSP430FR2000IRLL	0.5	512	3 × CCR ⁽³⁾	1	–	1	12	24 RLL (VQFN)

(1) For the most current device, package, and ordering information, see the *Package Option Addendum* in [§ 9](#), or see the TI website at www.ti.com.

(2) Package drawings, standard packing quantities, thermal data, symbolization, and PCB design guidelines are available at www.ti.com/packaging

(3) A CCR register is a configurable register that provides internal and external capture or compare inputs, or internal and external PWM outputs.

3.1 Related Products

For information about other devices in this family of products or related products, see the following links.

TI 16-bit and 32-bit Microcontrollers High-performance, low-power solutions to enable the autonomous future

Products for MSP430 Ultra-Low-Power Sensing and Measurement Microcontrollers One platform. One ecosystem. Endless possibilities.

Products for MSP430 Value Line Microcontrollers Low-cost, ultra-low-power MCUs for simple sensing and measurement applications

Companion Products for MSP430FR2111 Review products that are frequently purchased or used with this product.

Reference Designs for MSP430FR2111 The TI Designs Reference Design Library is a robust reference design library that spans analog, embedded processor, and connectivity. Created by TI experts to help you jump start your system design, all TI Designs include schematic or block diagrams, BOMs, and design files to speed your time to market. Search and download designs at ti.com/tidesigns.

4 Terminal Configuration and Functions

4.1 Pin Diagrams

Figure 4-1 shows the pinout of the 16-pin PW package.

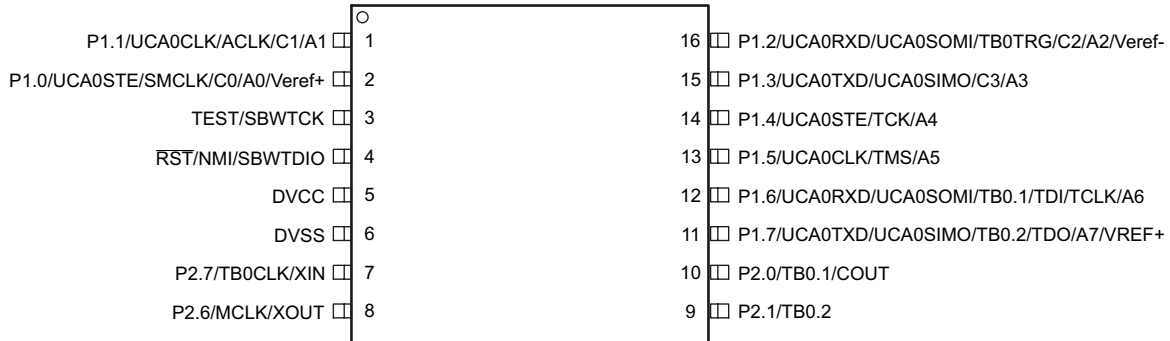

NOTE: The ADC (signals A0 to A7, Verif+, and Verif-) is not available on the MSP430FR2000 device.

Figure 4-1. 16-Pin PW (TSSOP) (Top View)

Figure 4-2 shows the pinout of the 24-pin RLL package.

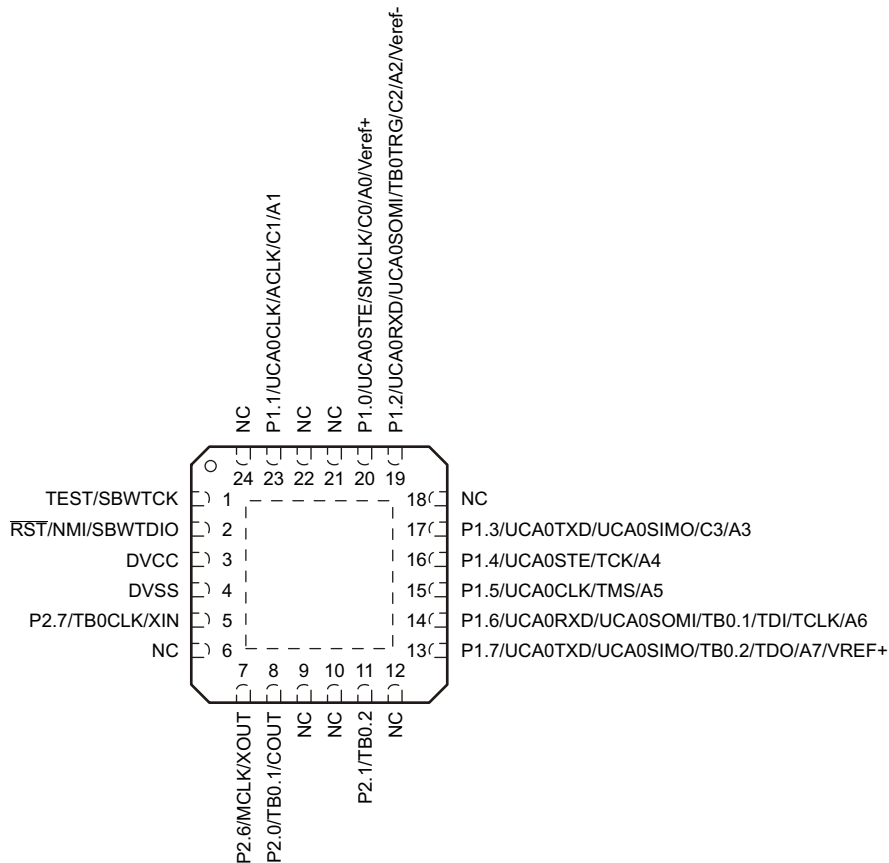

NOTE: The ADC (signals A0 to A7, Verif+, and Verif-) is not available on the MSP430FR2000 device.

Figure 4-2. 24-Pin RLL (VQFN) (Top View)

4.2 Pin Attributes

Table 4-1 lists the attributes of all pins.

Table 4-1. Pin Attributes

PIN NUMBER		SIGNAL NAME ^{(1) (2)}	SIGNAL TYPE ⁽³⁾	BUFFER TYPE ⁽⁴⁾	POWER SOURCE	RESET STATE AFTER BOR ⁽⁵⁾
PW16	RLL					
1	23	P1.1 (RD)	I/O	LVC MOS	DVCC	OFF
		UCA0CLK	I/O	LVC MOS	DVCC	–
		ACLK	O	LVC MOS	DVCC	–
		C1	I	Analog	DVCC	–
		A1 ⁽⁶⁾	I	Analog	DVCC	–
2	20	P1.0 (RD)	I/O	LVC MOS	DVCC	OFF
		UCA0STE	I/O	LVC MOS	DVCC	–
		SMCLK	O	LVC MOS	DVCC	–
		C0	I	Analog	DVCC	–
		A0 ⁽⁶⁾	I	Analog	DVCC	–
		Veref+ ⁽⁶⁾	I	Power	DVCC	–
3	1	TEST (RD)	I	LVC MOS	DVCC	OFF
		SBWTCK	I	LVC MOS	DVCC	–
4	2	$\overline{\text{RST}}$ (RD)	I/O	LVC MOS	DVCC	OFF
		NMI	I	LVC MOS	DVCC	–
		SBWTDIO	I/O	LVC MOS	DVCC	–
5	3	DVCC	P	Power	DVCC	N/A
6	4	DVSS	P	Power	DVCC	N/A
7	5	P2.7 (RD)	I/O	LVC MOS	DVCC	OFF
		TB0CLK	I	LVC MOS	DVCC	–
		XIN	I	LVC MOS	DVCC	–
8	7	P2.6 (RD)	I/O	LVC MOS	DVCC	OFF
		MCLK	O	LVC MOS	DVCC	–
		XOUT	O	LVC MOS	DVCC	–
9	11	P2.1(RD)	I/O	LVC MOS	DVCC	OFF
		TB0.2	I/O	LVC MOS	DVCC	–
10	8	P2.0 (RD)	I/O	LVC MOS	DVCC	OFF
		TB0.1	I/O	LVC MOS	DVCC	–
		COUT	O	LVC MOS	DVCC	–
11	13	P1.7 (RD)	I/O	LVC MOS	DVCC	OFF
		UCA0TXD	O	LVC MOS	DVCC	–
		UCA0SIMO	I/O	LVC MOS	DVCC	–
		TB0.2	I/O	LVC MOS	DVCC	–
		TDO	O	LVC MOS	DVCC	–
		A7 ⁽⁶⁾	I	Analog	DVCC	–
		VREF+	O	Power	DVCC	–

(1) Signals names with (RD) denote the reset default pin name.

(2) To determine the pin mux encodings for each pin, see [Section 6.11.15](#).

(3) Signal Types: I = Input, O = Output, I/O = Input or Output.

(4) Buffer Types: LVC MOS, Analog, or Power (see [Section 4.6](#))

(5) Reset States:

OFF = High-impedance input with pullup or pulldown disabled (if available)

N/A = Not applicable

(6) The ADC is not available on the MSP430FR2000 device.

Table 4-1. Pin Attributes (continued)

PIN NUMBER		SIGNAL NAME ⁽¹⁾ (2)	SIGNAL TYPE ⁽³⁾	BUFFER TYPE ⁽⁴⁾	POWER SOURCE	RESET STATE AFTER BOR ⁽⁵⁾
PW16	RLL					
12	14	P1.6 (RD)	I/O	LVC MOS	DVCC	OFF
		UCA0RXD	I	LVC MOS	DVCC	–
		UCA0SOMI	I/O	LVC MOS	DVCC	–
		TB0.1	I/O	LVC MOS	DVCC	–
		TDI	I	LVC MOS	DVCC	–
		TCLK	I	LVC MOS	DVCC	–
		A6 ⁽⁶⁾	I	Analog	DVCC	–
13	15	P1.5 (RD)	I/O	LVC MOS	DVCC	OFF
		UCA0CLK	I/O	LVC MOS	DVCC	–
		TMS	I	LVC MOS	DVCC	–
		A5 ⁽⁶⁾	I	Analog	DVCC	–
14	16	P1.4 (RD)	I/O	LVC MOS	DVCC	OFF
		UCA0STE	I/O	LVC MOS	DVCC	–
		TCK	I	LVC MOS	DVCC	–
		A4 ⁽⁶⁾	I	Analog	DVCC	–
15	17	P1.3 (RD)	I/O	LVC MOS	DVCC	OFF
		UCA0TXD	O	LVC MOS	DVCC	–
		UCA0SIMO	I/O	LVC MOS	DVCC	–
		C3	I	Analog	DVCC	–
		A3 ⁽⁶⁾	I	Analog	DVCC	–
16	19	P1.2 (RD)	I/O	LVC MOS	DVCC	OFF
		UCA0RXD	I	LVC MOS	DVCC	–
		UCA0SOMI	I/O	LVC MOS	DVCC	–
		TB0TRG	I	LVC MOS	DVCC	–
		C2	I	Analog	DVCC	–
		A2 ⁽⁶⁾	I	Analog	DVCC	–
		Verif- ⁽⁶⁾	I	Power	DVCC	–
	6, 9, 10, 12, 18, 21, 22, 24	NC ⁽⁷⁾	–	–	–	–

(7) NC = Not connected

4.3 Signal Descriptions

Table 4-2 describes the signals for all device variants and package options.

Table 4-2. Signal Descriptions

FUNCTION	SIGNAL NAME	PIN NUMBER		PIN TYPE	DESCRIPTION
		PW16	RLL		
ADC ⁽¹⁾	A0	2	20	I	Analog input A0
	A1	1	23	I	Analog input A1
	A2	16	19	I	Analog input A2
	A3	15	17	I	Analog input A3
	A4	14	16	I	Analog input A4
	A5	13	15	I	Analog input A5
	A6	12	14	I	Analog input A6
	A7	11	13	I	Analog input A7
	Vref+	2	20	I	ADC positive reference
	Vref-	16	19	I	ADC negative reference
eCOMP0	C0	2	20	I	Comparator input channel C0
	C1	1	23	I	Comparator input channel C1
	C2	16	19	I	Comparator input channel C2
	C3	15	17	I	Comparator input channel C3
	COUT	10	8	O	Comparator output channel COUT
Clock	ACLK	1	23	O	ACLK output
	MCLK	8	7	O	MCLK output
	SMCLK	2	20	O	SMCLK output
	XIN	7	5	I	Input terminal for crystal oscillator
	XOUT	8	7	O	Output terminal for crystal oscillator
Debug	SBWTCK	3	1	I	Spy-Bi-Wire input clock
	SBWTDIO	4	2	I/O	Spy-Bi-Wire data input/output
	TCK	14	16	I	Test clock
	TCLK	12	14	I	Test clock input
	TDI	12	14	I	Test data input
	TDO	11	13	O	Test data output
	TMS	13	15	I	Test mode select
	TEST	3	1	I	Test mode pin – selected digital I/O on JTAG pins
System	NMI	4	2	I	Nonmaskable interrupt input
	$\overline{\text{RST}}$	4	2	I/O	Reset input, active low
Power	DVCC	5	3	P	Power supply
	DVSS	6	4	P	Power ground
	VREF+	11	13	P	Output of positive reference voltage with ground as reference

(1) The ADC is not available on the MSP430FR2000 device.

Table 4-2. Signal Descriptions (continued)

FUNCTION	SIGNAL NAME	PIN NUMBER		PIN TYPE	DESCRIPTION
		PW16	RLL		
GPIO	P1.0	2	20	I/O	General-purpose I/O
	P1.1	1	23	I/O	General-purpose I/O
	P1.2	16	19	I/O	General-purpose I/O
	P1.3	15	17	I/O	General-purpose I/O
	P1.4	14	16	I/O	General-purpose I/O ⁽²⁾
	P1.5	13	15	I/O	General-purpose I/O ⁽²⁾
	P1.6	12	14	I/O	General-purpose I/O ⁽²⁾
	P1.7	11	13	I/O	General-purpose I/O ⁽²⁾
	P2.0	10	8	I/O	General-purpose I/O
	P2.1	9	11	I/O	General-purpose I/O
	P2.6	8	7	I/O	General-purpose I/O
	P2.7	7	5	I/O	General-purpose I/O
	SPI and UART	UCA0CLK	13	15	I/O
UCA0RXD		12	14	I	eUSCI_A0 UART receive data
UCA0SIMO		11	13	I/O	eUSCI_A0 SPI slave in/master out
UCA0SOMI		12	14	I/O	eUSCI_A0 SPI slave out/master in
UCA0STE		14	16	I/O	eUSCI_A0 SPI slave transmit enable
UCA0TXD		11	13	O	eUSCI_A0 UART transmit data
UCA0CLK ⁽³⁾		1	23	I/O	eUSCI_A0 SPI clock input/output
UCA0RXD ⁽³⁾		16	19	I	eUSCI_A0 UART receive data
UCA0SIMO ⁽³⁾		15	17	I/O	eUSCI_A0 SPI slave in/master out
UCA0SOMI ⁽³⁾		16	19	I/O	eUSCI_A0 SPI slave out/master in
UCA0STE ⁽³⁾		2	20	I/O	eUSCI_A0 SPI slave transmit enable
UCA0TXD ⁽³⁾		15	17	O	eUSCI_A0 UART transmit data
Timer_B	TB0.1	12	14	I/O	Timer TB0 CCR1 capture: CCI1A input, compare: Out1 outputs
	TB0.2	11	13	I/O	Timer TB0 CCR2 capture: CCI2A input, compare: Out2 outputs
	TB0CLK	7	5	I	Timer clock input TBCLK for TB0
	TB0TRG	16	19	I	TB0 external trigger input for TB0OUTH
	TB0.1 ⁽⁴⁾	10	8	I/O	Timer TB0 CCR1 capture: CCI1A input, compare: Out1 outputs
	TB0.2 ⁽⁴⁾	9	11	I/O	Timer TB0 CCR2 capture: CCI2A input, compare: Out2 outputs
NC pad	NC	–	6, 9, 10, 12, 18, 21, 22, 24	–	Do not connect
VQFN pad	Pad	–	Pad		VQFN package (RLL) exposed thermal pad. Connect to V _{SS} .

- (2) Because this pin is multiplexed with the JTAG function, TI recommends disabling the pin interrupt function while in JTAG debug to prevent collisions.
- (3) This is the remapped functionality controlled by the USCIARMP bit in the SYSCFG3 register. Only one selected port is valid at the same time.
- (4) This is the remapped functionality controlled by the TBRMP bit in the SYSCFG3 register. Only one selected port is valid at the same time when TB0 acts as capture input functionality. TB0 PWM outputs regardless of the setting on this remap bit.

4.4 Pin Multiplexing

Pin multiplexing for these devices is controlled by both register settings and operating modes (for example, if the device is in test mode). For details of the settings for each pin and schematics of the multiplexed ports, see [Section 6.11.15](#).

4.5 Connection of Unused Pins

[Table 4-3](#) lists the correct termination of unused pins.

Table 4-3. Connection of Unused Pins⁽¹⁾

PIN	POTENTIAL	COMMENT
Px.0 to Px.7	Open	Set to port function, output direction (PxDIR.n = 1)
$\overline{\text{RST}}/\text{NMI}$	DVCC	47-k Ω pullup or internal pullup selected with 10-nF (1.1 nF) pulldown ⁽²⁾
TEST	Open	This pin always has an internal pulldown enabled.

- (1) Any unused pin with a secondary function that is shared with general-purpose I/O should follow the Px.0 to Px.7 unused pin connection guidelines.
- (2) The pulldown capacitor should not exceed 1.1 nF when using devices with Spy-Bi-Wire interface in Spy-Bi-Wire mode with TI tools like FET interfaces or GANG programmers.

4.6 Buffer Type

[Table 4-4](#) defines the pin buffer types that are listed in [Table 4-1](#).

Table 4-4. Buffer Type

BUFFER TYPE (STANDARD)	NOMINAL VOLTAGE	HYSTERESIS	PU OR PD	NOMINAL PU OR PD STRENGTH (μA)	OUTPUT DRIVE STRENGTH (mA)	OTHER CHARACTERISTICS
LVC MOS	3.0 V	Υ ⁽¹⁾	Programmable	See Section 5.13.4	See Section 5.13.4.1	
Analog	3.0 V	No	No	N/A	N/A	See the analog modules in Section 5 for details.
Power (DVCC)	3.0 V	No	No	N/A	N/A	SVS enables hysteresis on DVCC.
Power (AVCC)	3.0 V	No	No	N/A	N/A	

- (1) Only for input pins

5 Specifications

5.1 Absolute Maximum Ratings⁽¹⁾

Over operating free-air temperature range (unless otherwise noted)

	MIN	MAX	UNIT
Voltage applied at DVCC pin to V _{SS}	-0.3	4.1	V
Voltage applied to any pin ⁽²⁾	-0.3	V _{CC} + 0.3 (4.1 V Max)	V
Diode current at any device pin		±2	mA
Maximum junction temperature, T _J		85	°C
Storage temperature range, T _{stg} ⁽³⁾	-40	125	°C

- (1) Stresses beyond those listed under *Absolute Maximum Ratings* may cause permanent damage to the device. These are stress ratings only, and functional operation of the device at these or any other conditions beyond those indicated under *Recommended Operating Conditions* is not implied. Exposure to absolute-maximum-rated conditions for extended periods may affect device reliability.
- (2) All voltages are referenced to V_{SS}.
- (3) Higher temperature may be applied during board soldering according to the current JEDEC J-STD-020 specification with peak reflow temperatures not higher than classified on the device label on the shipping boxes or reels.

5.2 ESD Ratings

		VALUE	UNIT
V _(ESD) Electrostatic discharge	Human-body model (HBM), per ANSI/ESDA/JEDEC JS-001 ⁽¹⁾	±1000	V
	Charged-device model (CDM), per JEDEC specification JESD22-C101 ⁽²⁾	±250	

- (1) JEDEC document JEP155 states that 500-V HBM allows safe manufacturing with a standard ESD control process. Manufacturing with less than 500-V HBM is possible with the necessary precautions. Pins listed as ±1000 V may actually have higher performance.
- (2) JEDEC document JEP157 states that 250-V CDM allows safe manufacturing with a standard ESD control process. Manufacturing with less than 250-V CDM is possible with the necessary precautions. Pins listed as ±250 V may actually have higher performance.

5.3 Recommended Operating Conditions

		MIN	NOM	MAX	UNIT
V _{CC}	Supply voltage applied at DVCC pin ⁽¹⁾ ⁽²⁾	1.8		3.6	V
V _{SS}	Supply voltage applied at DVSS pin		0		V
T _A	Operating free-air temperature	-40		85	°C
T _J	Operating junction temperature	-40		85	°C
C _{DVCC}	Recommended capacitor at DVCC	4.7	10		µF
f _{SYSTEM}	Processor frequency (maximum MCLK frequency) ⁽³⁾ ⁽⁴⁾	No FRAM wait states (NWAITSx = 0)		8	MHz
		With FRAM wait states (NWAITSx = 1) ⁽⁵⁾		16 ⁽⁶⁾	
f _{ACLK}	Maximum ACLK frequency			40	kHz
f _{SMCLK}	Maximum SMCLK frequency			16 ⁽⁶⁾	MHz

- (1) Supply voltage changes faster than 0.2 V/µs can trigger a BOR reset even within the recommended supply voltage range.
- (2) Modules may have a different supply voltage range specification. See the specification of the respective module in this data sheet.
- (3) The minimum supply voltage is defined by the SVS levels. See the SVS threshold parameters in [Table 5-1](#).
- (4) Modules may have a different maximum input clock specification. See the specification of the respective module in this data sheet.
- (5) Wait states only occur on actual FRAM accesses (that is, on FRAM cache misses). RAM and peripheral accesses are always executed without wait states.
- (6) If clock sources such as HF crystals or the DCO with frequencies >16 MHz are used, the clock must be divided in the clock system to comply with this operating condition.

5.4 Active Mode Supply Current Into V_{CC} Excluding External Current

See ⁽¹⁾

PARAMETER	EXECUTION MEMORY	TEST CONDITION	FREQUENCY ($f_{MCLK} = f_{SMCLK}$)						UNIT
			1 MHz 0 WAIT STATES (NWAITS _x = 0)		8 MHz 0 WAIT STATES (NWAITS _x = 0)		16 MHz 1 WAIT STATE (NWAITS _x = 1)		
			TYP	MAX	TYP	MAX	TYP	MAX	
$I_{AM, FRAM}$ (0%)	FRAM 0% cache hit ratio	3.0 V, 25°C	460		2670		2940	μA	
		3.0 V, 85°C	475		2730		2980		
$I_{AM, FRAM}$ (100%)	FRAM 100% cache hit ratio	3.0 V, 25°C	191		570		942	μA	
		3.0 V, 85°C	199		585		960		
$I_{AM, RAM}$ ⁽²⁾	RAM	3.0 V, 25°C	213		739		1244	μA	

(1) All inputs are tied to 0 V or to V_{CC} . Outputs do not source or sink any current. Characterized with program executing typical data processing.

$f_{ACLK} = 32768$ Hz, $f_{MCLK} = f_{SMCLK} = f_{DCO}$ at specified frequency

Program and data entirely reside in FRAM. All execution is from FRAM.

(2) Program and data reside entirely in RAM. All execution is from RAM. No access to FRAM.

5.5 Active Mode Supply Current Per MHz

$V_{CC} = 3.0$ V, $T_A = 25^\circ C$ (unless otherwise noted)

PARAMETER	TEST CONDITIONS	TYP	UNIT
$dI_{AM,FRAM}/df$ Active mode current consumption per MHz, execution from FRAM, no wait states ⁽¹⁾	$[(I_{AM} \text{ 75\% cache hit rate at 8 MHz}) - (I_{AM} \text{ 75\% cache hit rate at 1 MHz})] / 7$ MHz	120	$\mu A/MHz$

(1) All peripherals are turned on in default settings.

5.6 Low-Power Mode LPM0 Supply Currents Into V_{CC} Excluding External Current

$V_{CC} = 3.0$ V, $T_A = 25^\circ C$ (unless otherwise noted) ⁽¹⁾ ⁽²⁾

PARAMETER	V_{CC}	FREQUENCY (f_{SMCLK})						UNIT
		1 MHz		8 MHz		16 MHz		
		TYP	MAX	TYP	MAX	TYP	MAX	
I_{LPM0}	2.0 V	148		295		398	μA	
	3.0 V	157		304		402		

(1) All inputs are tied to 0 V or to V_{CC} . Outputs do not source or sink any current.

(2) Current for watchdog timer clocked by SMCLK included.

$f_{ACLK} = 32768$ Hz, $f_{MCLK} = 0$ MHz, f_{SMCLK} at specified frequency.

5.7 Low-Power Mode LPM3, LPM4 Supply Currents (Into V_{CC}) Excluding External Current

over recommended ranges of supply voltage and operating free-air temperature (unless otherwise noted) ⁽¹⁾ (see Figure 5-1)

PARAMETER	V _{CC}	TEMPERATURE						UNIT
		-40°C		25°C		85°C		
		TYP	MAX	TYP	MAX	TYP	MAX	
I _{LPM3,XT1} Low-power mode 3, includes SVS ^{(2) (3) (4)}	3.0 V	0.95		1.07		2.13	6.00	μA
	2.0 V	0.92		1.03		2.09		
I _{LPM3,VLO} Low-power mode 3, VLO, excludes SVS ⁽⁵⁾	3.0 V	0.76		0.87		1.94	5.70	μA
	2.0 V	0.74		0.85		1.90		
I _{LPM3, RTC} Low-power mode 3, RTC, excludes SVS ⁽⁶⁾	3.0 V	0.88		1.00		2.06		μA
	2.0 V	0.86		0.98		2.02		
I _{LPM4, SVS} Low-power mode 4, includes SVS	3.0 V	0.49		0.58		1.60		μA
	2.0 V	0.46		0.56		1.57		
I _{LPM4} Low-power mode 4, excludes SVS	3.0 V	0.33		0.42		1.44		μA
	2.0 V	0.32		0.41		1.42		
I _{LPM4, RTC, VLO} Low-power mode 4, RTC is sourced from VLO, excludes SVS	3.0 V	0.48		0.59		1.91		μA
	2.0 V	0.48		0.58		1.89		
I _{LPM4, RTC, XT1} Low-power mode 4, RTC is sourced from XT1, excludes SVS	3.0 V	0.89		1.04		2.41		μA
	2.0 V	0.88		1.02		2.38		

- (1) All inputs are tied to 0 V or to V_{CC}. Outputs do not source or sink any current
- (2) Not applicable for devices with HF crystal oscillator only.
- (3) Characterized with a Seiko Crystal SC-32S MS1V-T1K crystal with a load capacitance chosen to closely match the required load.
- (4) Low-power mode 3, includes SVS test conditions:
Current for watchdog timer clocked by ACLK and RTC clocked by XT1 included. Current for brownout and SVS included (SVSHE = 1). CPUOFF = 1, SCG0 = 1 SCG1 = 1, OSCOFF = 0 (LPM3), f_{XT1} = 32768 Hz, f_{ACLK} = f_{XT1}, f_{MCLK} = f_{SMCLK} = 0 MHz
- (5) Low-power mode 3, VLO, excludes SVS test conditions:
Current for watchdog timer clocked by VLO included. RTC disabled. Current for brownout included. SVS disabled (SVSHE = 0). CPUOFF = 1, SCG0 = 1 SCG1 = 1, OSCOFF = 0 (LPM3), f_{XT1} = 32768 Hz, f_{MCLK} = f_{SMCLK} = 0 MHz
- (6) RTC periodically wakes every second with external 32768-Hz as source.

5.8 Typical Characteristics – LPM3 Supply Currents

3 V at 25°C and 3 V at 85°C

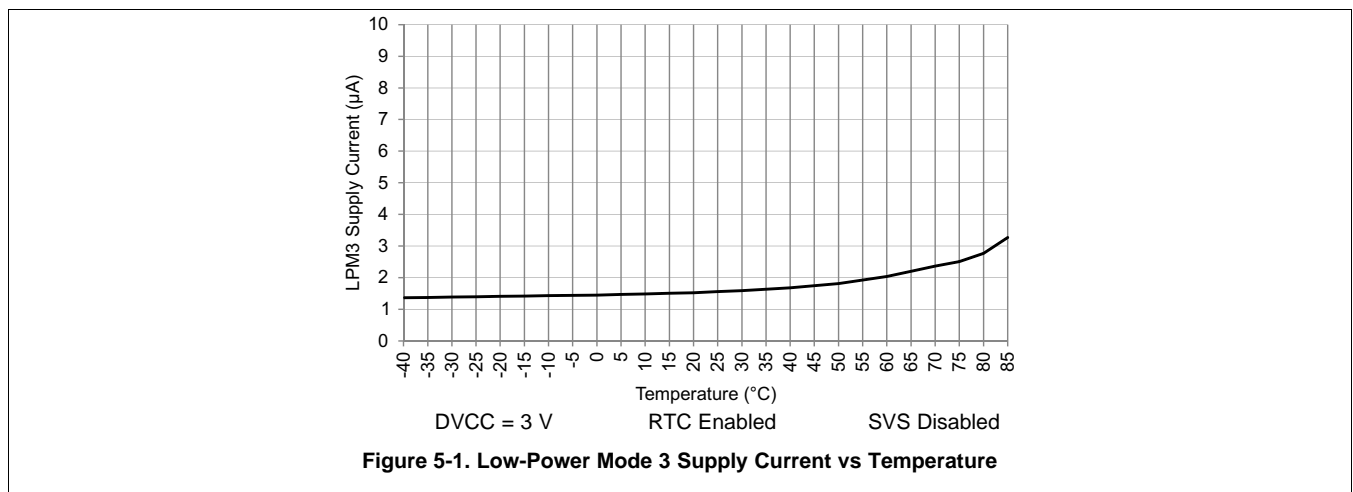

5.9 Low-Power Mode LPMx.5 Supply Currents (Into V_{CC}) Excluding External Current

over recommended ranges of supply voltage and operating free-air temperature (unless otherwise noted)

PARAMETER	V_{CC}	TEMPERATURE						UNIT
		-40°C		25°C		85°C		
		TYP	MAX	TYP	MAX	TYP	MAX	
$I_{LPM3.5, XT1}$ Low-power mode 3.5, includes SVS ^{(1) (2) (3)} (also see Figure 5-2)	3.0 V	0.60		0.66		0.80	2.17	μ A
	2.0 V	0.57		0.64		0.75		
$I_{LPM4.5, SVS}$ Low-power mode 4.5, includes SVS ⁽⁴⁾	3.0 V	0.23		0.25		0.32	0.43	μ A
	2.0 V	0.20		0.23		0.27		
$I_{LPM4.5}$ Low-power mode 4.5, excludes SVS ⁽⁵⁾ (also see Figure 5-3)	3.0 V	0.025		0.034		0.064	0.130	μ A
	2.0 V	0.021		0.029		0.055		

(1) Not applicable for devices with HF crystal oscillator only.

(2) Characterized with a Seiko Crystal SC-32S crystal with a load capacitance chosen to closely match the required load.

(3) Low-power mode 3.5, includes SVS test conditions:
Current for RTC clocked by XT1 included. Current for brownout and SVS included (SVSHE = 1). Core regulator disabled.
PMMREGOFF = 1, CPUOFF = 1, SCG0 = 1 SCG1 = 1, OSCOFF = 1 (LPMx.5),
 $f_{XT1} = 32768$ Hz, $f_{ACLK} = f_{XT1}$, $f_{MCLK} = f_{SMCLK} = 0$ MHz

(4) Low-power mode 4.5, includes SVS test conditions:
Current for brownout and SVS included (SVSHE = 1). Core regulator disabled.
PMMREGOFF = 1, CPUOFF = 1, SCG0 = 1 SCG1 = 1, OSCOFF = 1 (LPMx.5),
 $f_{XT1} = 0$ Hz, $f_{ACLK} = f_{MCLK} = f_{SMCLK} = 0$ MHz

(5) Low-power mode 4.5, excludes SVS test conditions:
Current for brownout included. SVS disabled (SVSHE = 0). Core regulator disabled.
PMMREGOFF = 1, CPUOFF = 1, SCG0 = 1 SCG1 = 1, OSCOFF = 1 (LPMx.5),
 $f_{XT1} = 0$ Hz, $f_{ACLK} = f_{MCLK} = f_{SMCLK} = 0$ MHz

5.10 Typical Characteristics – LPMx.5 Supply Currents

3 V at 25°C and 3 V at 85°C

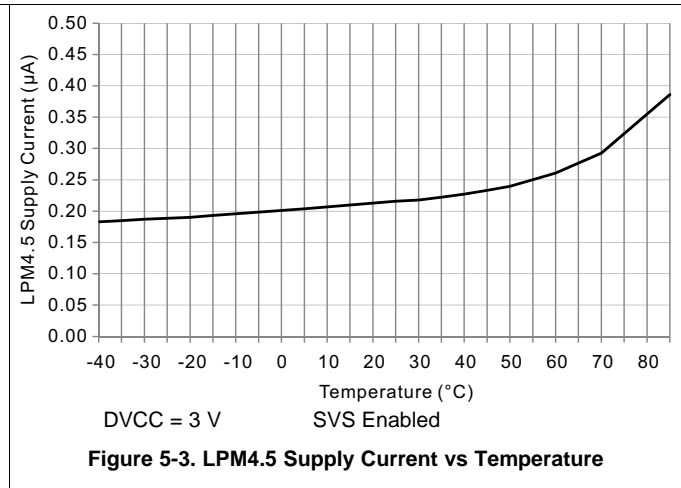
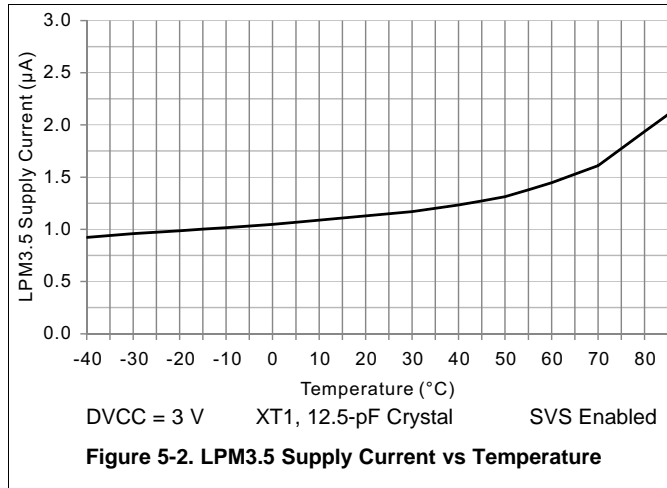

5.11 Typical Characteristics - Current Consumption Per Module

MODULE	TEST CONDITIONS	REFERENCE CLOCK	MIN	TYP	MAX	UNIT
Timer_B	SMCLK = 8 Hz, MC = 10	Module input clock		5		μ A/MHz
eUSCI_A	UART mode	Module input clock		7		μ A/MHz
eUSCI_A	SPI mode	Module input clock		5		μ A/MHz
RTC		32 kHz		85		nA
CRC	From start to end of operation	MCLK		8.5		μ A/MHz

5.12 Thermal Resistance Characteristics

THERMAL METRIC ⁽¹⁾ ⁽²⁾		VALUE	UNIT
R θ _{JA}	Junction-to-ambient thermal resistance, still air	VQFN 24 pin (RLL)	38.7
		TSSOP 16 pin (PW16)	106.5
R θ _{JC}	Junction-to-case (top) thermal resistance	VQFN 24 pin (RLL)	39.5
		TSSOP 16 pin (PW16)	41.2
R θ _{JB}	Junction-to-board thermal resistance	VQFN 24 pin (RLL)	8.6
		TSSOP 16 pin (PW16)	51.5

- (1) For more information about traditional and new thermal metrics, see [Semiconductor and IC Package Thermal Metrics](#).
- (2) These values are based on a JEDEC-defined 2S2P system (with the exception of the Theta JC [R θ _{JC}] value, which is based on a JEDEC-defined 1S0P system) and will change based on environment and application. For more information, see these EIA/JEDEC standards:
- JESD51-2, *Integrated Circuits Thermal Test Method Environmental Conditions - Natural Convection (Still Air)*
 - JESD51-3, *Low Effective Thermal Conductivity Test Board for Leaded Surface Mount Packages*
 - JESD51-7, *High Effective Thermal Conductivity Test Board for Leaded Surface Mount Packages*
 - JESD51-9, *Test Boards for Area Array Surface Mount Package Thermal Measurements*

5.13 Timing and Switching Characteristics

5.13.1 Power Supply Sequencing

Figure 5-4 shows the power cycle, SVS, and BOR reset conditions.

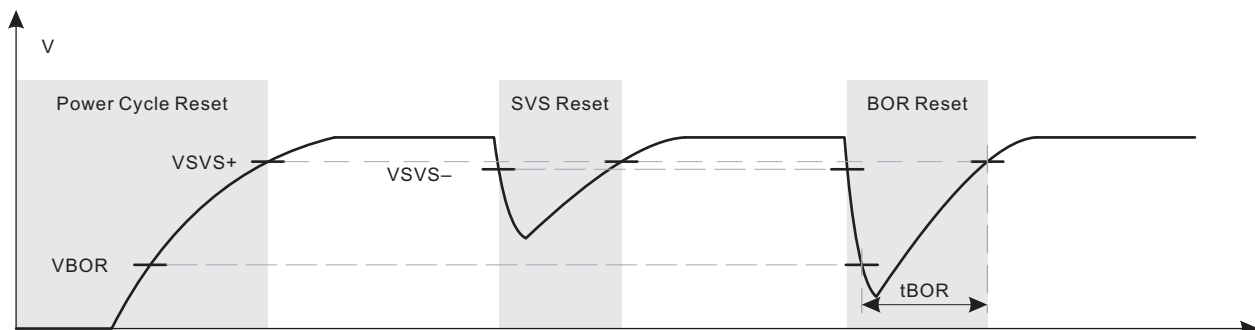

Figure 5-4. Power Cycle, SVS, and BOR Reset Conditions

Table 5-1 lists the characteristics of the SVS and BOR.

Table 5-1. PMM, SVS and BOR

over recommended ranges of supply voltage and operating free-air temperature (unless otherwise noted)

PARAMETER	TEST CONDITIONS	MIN	TYP	MAX	UNIT
V _{BOR, safe}	Safe BOR power-down level ⁽¹⁾	0.1			V
t _{BOR, safe}	Safe BOR reset delay ⁽²⁾	10			ms
I _{SVSH, AM}	SVS _H current consumption, active mode			1.5	μA
I _{SVSH, LPM}	SVS _H current consumption, low-power modes		240		nA
V _{SVSH-}	SVS _H power-down level ⁽³⁾	1.71	1.81	1.86	V
V _{SVSH+}	SVS _H power-up level ⁽³⁾	1.74	1.88	1.99	V
V _{SVSH_hys}	SVS _H hysteresis		80		mV
t _{PD, SVSH, AM}	SVS _H propagation delay, active mode			10	μs
t _{PD, SVSH, LPM}	SVS _H propagation delay, low-power modes			100	μs

- (1) A safe BOR can be correctly generated only if DVCC drops below this voltage before it rises.
- (2) When an BOR occurs, a safe BOR can be correctly generated only if DVCC is kept low longer than this period before it reaches V_{SVSH+}.
- (3) For additional information, see the [Dynamic Voltage Scaling Power Solution for MSP430 Devices With Single-Channel LDO Reference Design](#).

5.13.2 Reset Timing

Table 5-2 lists the wake-up time characteristics.

Table 5-2. Wake-up Times From Low-Power Modes and Reset

over recommended ranges of supply voltage and operating free-air temperature (unless otherwise noted)

PARAMETER		TEST CONDITIONS	V _{CC}	MIN	TYP	MAX	UNIT
t _{WAKE-UP FRAM}	(Additional) wake-up time to activate the FRAM in AM if previously disabled through the FRAM controller or from an LPM if immediate activation is selected for wakeup ⁽¹⁾		3 V		10		μs
t _{WAKE-UP LPM0}	Wake-up time from LPM0 to active mode ⁽¹⁾		3 V			200 + 2.5 / f _{DCO}	ns
t _{WAKE-UP LPM3}	Wake-up time from LPM3 to active mode ⁽¹⁾		3 V		10		μs
t _{WAKE-UP LPM4}	Wake-up time from LPM4 to active mode ⁽²⁾		3 V		10		μs
t _{WAKE-UP LPM3.5}	Wake-up time from LPM3.5 to active mode ⁽²⁾		3 V		350		μs
t _{WAKE-UP LPM4.5}	Wake-up time from LPM4.5 to active mode ⁽²⁾	SVSHE = 1	3 V		350		μs
		SVSHE = 0			1		ms
t _{WAKE-UP-RESET}	Wake-up time from $\overline{\text{RST}}$ or BOR event to active mode ⁽²⁾		3 V		1		ms
t _{RESET}	Pulse duration required at $\overline{\text{RST}}$ /NMI pin to accept a reset				2		μs

- (1) The wake-up time is measured from the edge of an external wake-up signal (for example, port interrupt or wake-up event) to the first externally observable MCLK clock edge.
- (2) The wake-up time is measured from the edge of an external wake-up signal (for example, port interrupt or wake-up event) until the first instruction of the user program is executed.

5.13.3 Clock Specifications

Table 5-3 lists the characteristics of the XT1 in low-frequency mode.

Table 5-3. XT1 Crystal Oscillator (Low Frequency)

over recommended ranges of supply voltage and operating free-air temperature (unless otherwise noted)⁽¹⁾

PARAMETER		TEST CONDITIONS	V _{CC}	MIN	TYP	MAX	UNIT
f _{XT1, LF}	XT1 oscillator crystal, low frequency	LFXTBYPASS = 0			32768		Hz
DC _{XT1, LF}	XT1 oscillator LF duty cycle	Measured at MCLK, f _{LFXT} = 32768 Hz		30%		70%	
f _{XT1, SW}	XT1 oscillator logic-level square-wave input frequency	LFXTBYPASS = 1 ⁽²⁾ ⁽³⁾			32768		Hz
DC _{XT1, SW}	LFXT oscillator logic-level square-wave input duty cycle	LFXTBYPASS = 1		40%		60%	
OA _{LFXT}	Oscillation allowance for LF crystals ⁽⁴⁾	LFXTBYPASS = 0, LFXTDRIVE = {3}, f _{LFXT} = 32768 Hz, C _{L,eff} = 12.5 pF			200		kΩ
C _{L,eff}	Integrated effective load capacitance ⁽⁵⁾	See ⁽⁶⁾			1		pF
t _{START, LFXT}	Start-up time ⁽⁷⁾	f _{OSC} = 32768 Hz LFXTBYPASS = 0, LFXTDRIVE = {3}, T _A = 25°C, C _{L,eff} = 12.5 pF			1000		ms
f _{Fault, LFXT}	Oscillator fault frequency ⁽⁸⁾	XTS = 0 ⁽⁹⁾		0		3500	Hz

- (1) To improve EMI on the LFXT oscillator, observe the following guidelines:
 - Keep the trace between the device and the crystal as short as possible.
 - Design a good ground plane around the oscillator pins.
 - Prevent crosstalk from other clock or data lines into oscillator pins XIN and XOUT.
 - Avoid running PCB traces underneath or adjacent to the XIN and XOUT pins.
 - Use assembly materials and processes that avoid any parasitic load on the oscillator XIN and XOUT pins.
 - If conformal coating is used, make sure that it does not induce capacitive or resistive leakage between the oscillator pins.
- (2) When LFXTBYPASS is set, LFXT circuits are automatically powered down. The input signal is a digital square wave with parametrics defined in Table 5-9. Duty cycle requirements are defined by DC_{LFXT, SW}.
- (3) Maximum frequency of operation of the entire device cannot be exceeded.
- (4) Oscillation allowance is based on a safety factor of 5 for recommended crystals. The oscillation allowance is a function of the LFXTDRIVE settings and the effective load. In general, comparable oscillator allowance can be achieved based on the following guidelines, but should be evaluated based on the actual crystal selected for the application:
 - For LFXTDRIVE = {0}, C_{L,eff} = 3.7 pF
 - For LFXTDRIVE = {1}, 6 pF ≤ C_{L,eff} ≤ 9 pF
 - For LFXTDRIVE = {2}, 6 pF ≤ C_{L,eff} ≤ 10 pF
 - For LFXTDRIVE = {3}, 6 pF ≤ C_{L,eff} ≤ 12 pF
- (5) Includes parasitic bond and package capacitance (approximately 2 pF per pin).
- (6) Requires external capacitors at both terminals. Values are specified by crystal manufacturers.
- (7) Includes start-up counter of 1024 clock cycles.
- (8) Frequencies above the MAX specification do not set the fault flag. Frequencies between the MIN and MAX specifications may set the flag. A static condition or stuck at fault condition sets the flag.
- (9) Measured with logic-level input frequency but also applies to operation with crystals.

Table 5-4 lists the frequency characteristics of the DCO FLL.

Table 5-4. DCO FLL, Frequency

Over recommended operating free-air temperature (unless otherwise noted)

PARAMETER		TEST CONDITIONS	V _{CC}	MIN	TYP	MAX	UNIT
f _{DCO, FLL}	FLL lock frequency, 16 MHz, 25°C	Measured at MCLK, internal trimmed REFO as reference	3.0 V	-1.0%		1.0%	
	FLL lock frequency, 16 MHz, -40°C to 85°C		3.0 V	-2.0%		2.0%	
	FLL lock frequency, 16 MHz, -40°C to 85°C	Measured at MCLK, XT1 crystal as reference	3.0 V	-0.5%		0.5%	
f _{DUTY}	Duty cycle	Measured at MCLK, XT1 crystal as reference	3.0 V	40%	50%	60%	
Jitter _{CC}	Cycle-to-cycle jitter, 16 MHz		3.0 V		0.25%		
Jitter _{long}	Long term Jitter, 16 MHz		3.0 V		0.022%		
t _{FLL, lock}	FLL lock time		3.0 V		245		ms

Table 5-5 lists the frequency characteristics of the DCO.

Table 5-5. DCO Frequency

Over recommended operating free-air temperature (unless otherwise noted) (see Figure 5-5)

PARAMETER		TEST CONDITIONS	V _{CC}	MIN	TYP	MAX	UNIT
f _{DCO, 16 MHz} ⁽¹⁾	DCO frequency, 16 MHz	DCORSEL = 101b, DISMOD = 1b, DCOFTRIM = 000b, DCO = 0	3.0 V		7.8		MHz
		DCORSEL = 101b, DISMOD = 1b, DCOFTRIM = 000b, DCO = 511			12.5		
		DCORSEL = 101b, DISMOD = 1b, DCOFTRIM = 111b, DCO = 0			18.0		
		DCORSEL = 101b, DISMOD = 1b, DCOFTRIM = 111b, DCO = 511			30.0		
f _{DCO, 12 MHz} ⁽¹⁾	DCO frequency, 12 MHz	DCORSEL = 100b, DISMOD = 1b, DCOFTRIM = 000b, DCO = 0	3.0 V		6.0		MHz
		DCORSEL = 100b, DISMOD = 1b, DCOFTRIM = 000b, DCO = 511			9.5		
		DCORSEL = 100b, DISMOD = 1b, DCOFTRIM = 111b, DCO = 0			13.5		
		DCORSEL = 100b, DISMOD = 1b, DCOFTRIM = 111b, DCO = 511			22.0		
f _{DCO, 8 MHz} ⁽¹⁾	DCO frequency, 8 MHz	DCORSEL = 011b, DISMOD = 1b, DCOFTRIM = 000b, DCO = 0	3.0 V		3.8		MHz
		DCORSEL = 011b, DISMOD = 1b, DCOFTRIM = 000b, DCO = 511			6.5		
		DCORSEL = 011b, DISMOD = 1b, DCOFTRIM = 111b, DCO = 0			9.5		
		DCORSEL = 011b, DISMOD = 1b, DCOFTRIM = 111b, DCO = 511			16.0		
f _{DCO, 4 MHz} ⁽¹⁾	DCO frequency, 4 MHz	DCORSEL = 010b, DISMOD = 1b, DCOFTRIM = 000b, DCO = 0	3.0 V		2.0		MHz
		DCORSEL = 010b, DISMOD = 1b, DCOFTRIM = 000b, DCO = 511			3.2		
		DCORSEL = 010b, DISMOD = 1b, DCOFTRIM = 111b, DCO = 0			4.8		
		DCORSEL = 010b, DISMOD = 1b, DCOFTRIM = 111b, DCO = 511			8.0		

(1) This frequency reflects the achievable frequency range when FLL is either enabled or disabled.

Table 5-5. DCO Frequency (continued)

Over recommended operating free-air temperature (unless otherwise noted) (see Figure 5-5)

PARAMETER	TEST CONDITIONS	V _{CC}	MIN	TYP	MAX	UNIT
f _{DCO, 2 MHz} ⁽¹⁾ DCO frequency, 2 MHz	DCORSEL = 001b, DISMOD = 1b, DCOFTRIM = 000b, DCO = 0	3.0 V		1.0		MHz
	DCORSEL = 001b, DISMOD = 1b, DCOFTRIM = 000b, DCO = 511			1.7		
	DCORSEL = 001b, DISMOD = 1b, DCOFTRIM = 111b, DCO = 0			2.5		
	DCORSEL = 001b, DISMOD = 1b, DCOFTRIM = 111b, DCO = 511			4.2		
f _{DCO, 1 MHz} ⁽¹⁾ DCO frequency, 1 MHz	DCORSEL = 000b, DISMOD = 1b, DCOFTRIM = 000b, DCO = 0	3.0 V		0.5		MHz
	DCORSEL = 000b, DISMOD = 1b, DCOFTRIM = 000b, DCO = 511			0.85		
	DCORSEL = 000b, DISMOD = 1b, DCOFTRIM = 111b, DCO = 0			1.2		
	DCORSEL = 000b, DISMOD = 1b, DCOFTRIM = 111b, DCO = 511			2.1		

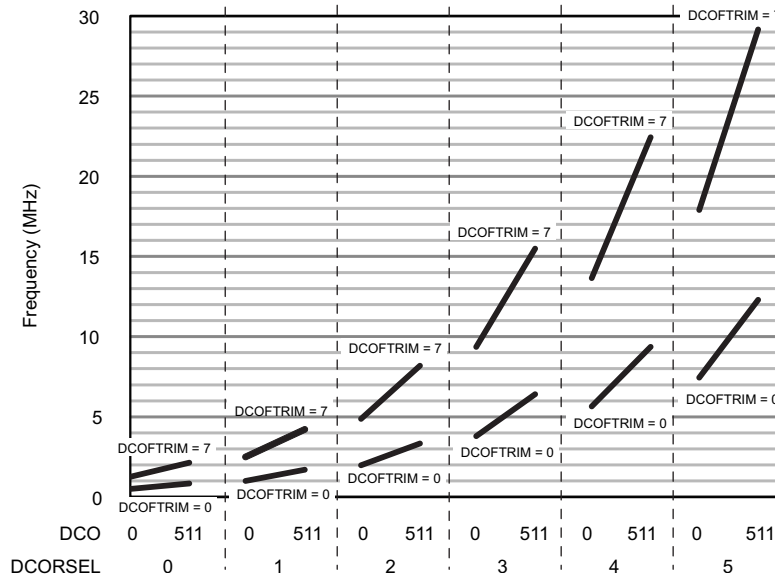

Figure 5-5. Typical DCO Frequency

Table 5-6 lists the characteristics of the REFO.

Table 5-6. REFO

Over recommended operating free-air temperature (unless otherwise noted)

PARAMETER	TEST CONDITIONS	V _{CC}	MIN	TYP	MAX	UNIT
I _{REFO}	REFO oscillator current consumption	T _A = 25°C		15		μA
f _{REFO}	REFO calibrated frequency	Measured at MCLK		32768		Hz
	REFO absolute calibrated tolerance	–40°C to 85°C	1.8 V to 3.6 V	–3.5%	+3.5%	
df _{REFO} /dT	REFO frequency temperature drift	Measured at MCLK ⁽¹⁾	3.0 V	0.01		%/°C
df _{REFO} /dV _{CC}	REFO frequency supply voltage drift	Measured at MCLK at 25°C ⁽²⁾	1.8 V to 3.6 V	1		%/V
f _{DC}	REFO duty cycle	Measured at MCLK	1.8V to 3.6 V	40%	50%	60%
t _{START}	REFO start-up time	40% to 60% duty cycle		50		μs

(1) Calculated using the box method: (MAX(–40°C to 85°C) – MIN(–40°C to 85°C)) / MIN(–40°C to 85°C) / (85°C – (–40°C))

(2) Calculated using the box method: (MAX(1.8 V to 3.6 V) – MIN(1.8 V to 3.6 V)) / MIN(1.8 V to 3.6 V) / (3.6 V – 1.8 V)

Table 5-7 lists the characteristics of the VLO.

Table 5-7. Internal Very-Low-Power Low-Frequency Oscillator (VLO)

over recommended ranges of supply voltage and operating free-air temperature (unless otherwise noted)

PARAMETER		TEST CONDITIONS	V _{CC}	MIN	TYP	MAX	UNIT
f _{VLO}	VLO frequency	Measured at MCLK	3.0 V		10		kHz
df _{VLO} /dT	VLO frequency temperature drift	Measured at MCLK ⁽¹⁾	3.0 V		0.5		%/°C
df _{VLO} /dV _{CC}	VLO frequency supply voltage drift	Measured at MCLK ⁽²⁾	1.8 V to 3.6 V		4		%/V
f	Duty cycle	Measured at MCLK	3.0 V		50%		

(1) Calculated using the box method: (MAX(−40°C to 85°C) – MIN(−40°C to 85°C)) / MIN(−40°C to 85°C) / (85°C – (−40°C))

(2) Calculated using the box method: (MAX(1.8 V to 3.6 V) – MIN(1.8 V to 3.6 V)) / MIN(1.8 V to 3.6 V) / (3.6 V – 1.8 V)

NOTE

The VLO clock frequency is reduced by 15% (typical) when the device switches from active mode to LPM3 or LPM4, because the reference changes. This lower frequency is not a violation of the VLO specifications (see Table 5-7).

Table 5-8 lists the characteristics of the MODOSC.

Table 5-8. Module Oscillator (MODOSC)

over recommended ranges of supply voltage and operating free-air temperature (unless otherwise noted)

PARAMETER		V _{CC}	MIN	TYP	MAX	UNIT
f _{MODOSC}	MODOSC frequency	3.0 V	3.8	4.8	5.8	MHz
f _{MODOSC} /dT	MODOSC frequency temperature drift	3.0 V		0.102		%/°C
f _{MODOSC} /dV _{CC}	MODOSC frequency supply voltage drift	1.8 V to 3.6 V		2.29		%/V
f _{MODOSC,DC}	Duty cycle	3.0 V	40%	50%	60%	

5.13.4 Digital I/Os

Table 5-9 lists the characteristics of the digital inputs.

Table 5-9. Digital Inputs

over recommended ranges of supply voltage and operating free-air temperature (unless otherwise noted)

PARAMETER		TEST CONDITIONS	V _{CC}	MIN	TYP	MAX	UNIT
V _{IT+}	Positive-going input threshold voltage		2 V	0.90		1.50	V
			3 V	1.35		2.25	
V _{IT−}	Negative-going input threshold voltage		2 V	0.50		1.10	V
			3 V	0.75		1.65	
V _{hys}	Input voltage hysteresis (V _{IT+} – V _{IT−})		2 V	0.3		0.8	V
			3 V	0.4		1.2	
R _{Pull}	Pullup or pulldown resistor	For pullup: V _{IN} = V _{SS} For pulldown: V _{IN} = V _{CC}		20	35	50	kΩ
C _{I,dig}	Input capacitance, digital only port pins	V _{IN} = V _{SS} or V _{CC}			3		pF
C _{I,ana}	Input capacitance, port pins with shared analog functions	V _{IN} = V _{SS} or V _{CC}			5		pF
I _{lkg(Px.y)}	High-impedance leakage current ⁽¹⁾⁽²⁾		2 V, 3 V	−20		+20	nA

(1) The leakage current is measured with V_{SS} or V_{CC} applied to the corresponding pins, unless otherwise noted.

(2) The leakage of the digital port pins is measured individually. The port pin is selected for input and the pullup/pulldown resistor is disabled.

Table 5-10 lists the characteristics of the digital outputs.

Table 5-10. Digital Outputs

over recommended ranges of supply voltage and operating free-air temperature (unless otherwise noted)

PARAMETER		TEST CONDITIONS	V _{CC}	MIN	TYP	MAX	UNIT
V _{OH}	High-level output voltage (also see Figure 5-8 and Figure 5-9)	I _(OHmax) = -3 mA ⁽¹⁾	2.0 V	1.4		2.0	V
		I _(OHmax) = -5 mA ⁽¹⁾	3.0 V	2.4		3.0	
V _{OL}	Low-level output voltage (also see Figure 5-6 and Figure 5-7)	I _(OLmax) = 3 mA ⁽¹⁾	2.0 V	0.0		0.60	V
		I _(OLmax) = 5 mA ⁽¹⁾	3.0 V	0.0		0.60	
f _{Port_CLK}	Clock output frequency	C _L = 20 pF ⁽²⁾	2.0 V	16			MHz
			3.0 V	16			
t _{rise,dig}	Port output rise time, digital only port pins	C _L = 20 pF	2.0 V		10		ns
			3.0 V		7		
t _{fall,dig}	Port output fall time, digital only port pins	C _L = 20 pF	2.0 V		10		ns
			3.0 V		5		

- (1) The maximum total current, I_(OHmax) and I_(OLmax), for all outputs combined should not exceed ±48 mA to hold the maximum voltage drop specified.
- (2) The port can output frequencies at least up to the specified limit and might support higher frequencies.

5.13.4.1 Digital I/O Typical Characteristics

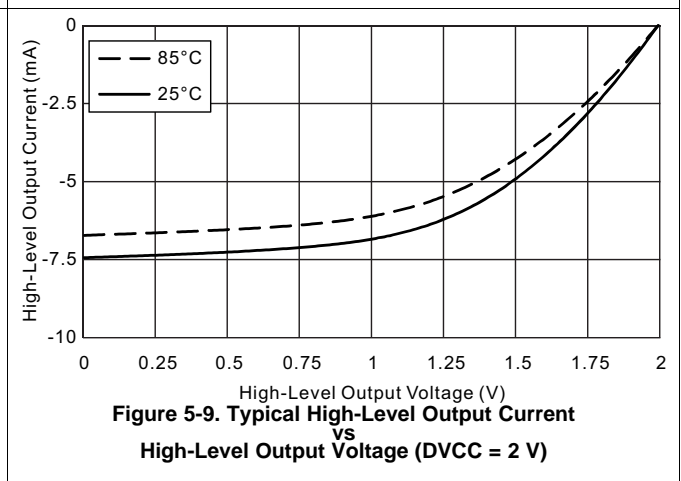
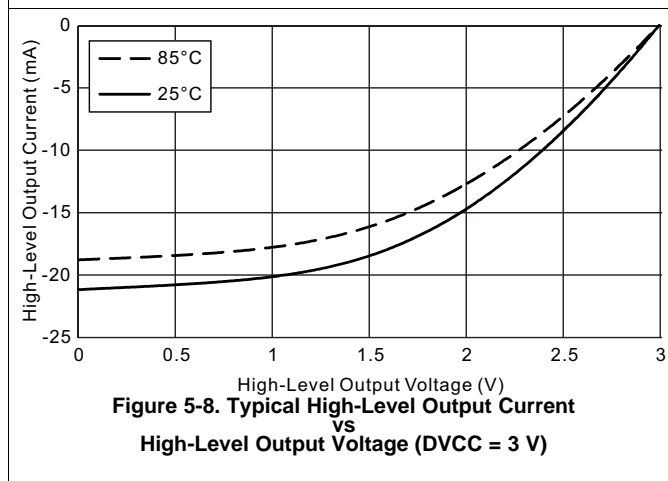
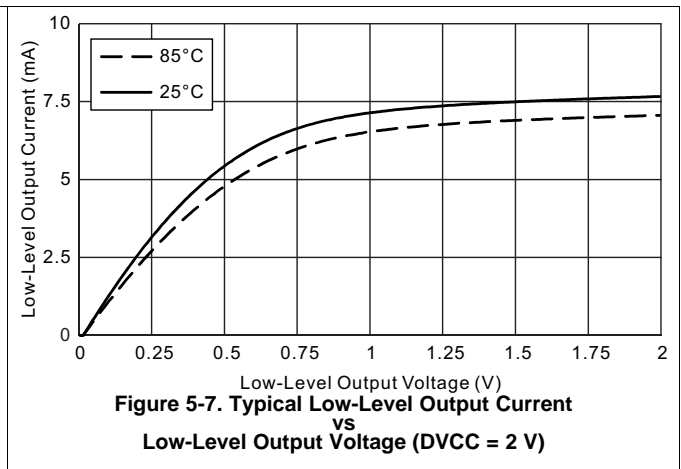
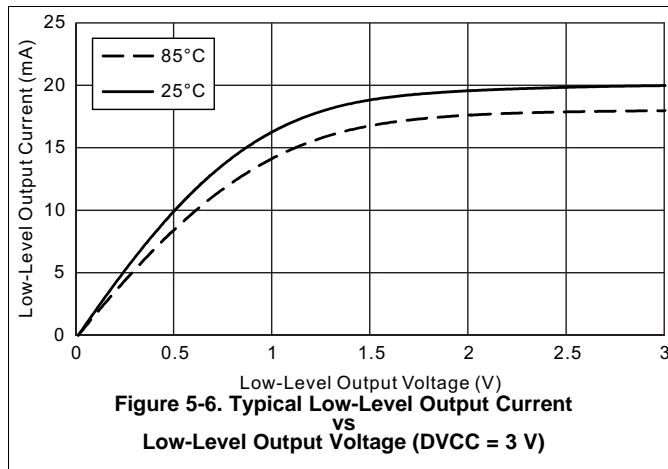

5.13.5 VREF+ Built-in Reference

Table 5-11 lists the characteristics of the VREF+.

Table 5-11. VREF+ Characteristics

over recommended ranges of supply voltage and operating free-air temperature (unless otherwise noted)

PARAMETER		TEST CONDITIONS	V _{CC}	MIN	TYP	MAX	UNIT
V _{REF+}	Positive built-in reference voltage	EXTREFEN = 1 with 1-mA load current	2.0 V, 3.0 V	1.158	1.2	1.242	V
T _{CREF+}	Temperature coefficient of built-in reference voltage	EXTREFEN = 1 with 1-mA load current			30		μV/°C

5.13.6 Timer_B

Table 5-12 lists the supported clock frequencies of Timer_B.

Table 5-12. Timer_B Clock Frequency

over recommended ranges of supply voltage and operating free-air temperature (unless otherwise noted)

PARAMETER		TEST CONDITIONS	V _{CC}	MIN	TYP	MAX	UNIT
f _{TB}	Timer_B input clock frequency	Internal: SMCLK or ACLK, External: TBCLK, duty cycle = 50% ±10%	2.0 V, 3.0 V			16	MHz

5.13.7 eUSCI

Table 5-13 lists the clock frequency characteristics of the eUSCI in UART mode.

Table 5-13. eUSCI (UART Mode) Clock Frequency

over recommended ranges of supply voltage and operating free-air temperature (unless otherwise noted)

PARAMETER		TEST CONDITIONS	V _{CC}	MIN	MAX	UNIT
f _{eUSCI}	eUSCI input clock frequency	Internal: SMCLK or MODCLK, External: UCLK, duty cycle = 50% ±10%	2.0 V, 3.0 V		16	MHz
f _{BITCLK}	BITCLK clock frequency (equals baud rate in Mbaud)		2.0 V, 3.0 V		5	MHz

Table 5-14 lists the switching characteristics of the eUSCI in UART mode.

Table 5-14. eUSCI (UART Mode) Switching Characteristics

over recommended ranges of supply voltage and operating free-air temperature (unless otherwise noted)

PARAMETER		TEST CONDITIONS	V _{CC}	MIN	TYP	MAX	UNIT
t _t	UART receive deglitch time ⁽¹⁾	UCGLITx = 0	2.0 V, 3.0 V		12		ns
		UCGLITx = 1			40		
		UCGLITx = 2			68		
		UCGLITx = 3			110		

- (1) Pulses on the UART receive input (UCxRX) shorter than the UART receive deglitch time are suppressed. To ensure that pulses are correctly recognized their width should exceed the maximum specification of the deglitch time.

Table 5-15 lists the clock frequency characteristics of the eUSCI in SPI master mode.

Table 5-15. eUSCI (SPI Master Mode) Clock Frequency

over recommended ranges of supply voltage and operating free-air temperature (unless otherwise noted)

PARAMETER		TEST CONDITIONS	MIN	MAX	UNIT
f _{eUSCI}	eUSCI input clock frequency	Internal: SMCLK or MODCLK, duty cycle = 50% ±10%		8	MHz

Table 5-16 lists the switching characteristics of the eUSCI in SPI master mode.

Table 5-16. eUSCI (SPI Master Mode) Switching Characteristics

over recommended ranges of supply voltage and operating free-air temperature (unless otherwise noted)⁽¹⁾

PARAMETER		TEST CONDITIONS	V _{CC}	MIN	MAX	UNIT
t _{STE,LEAD}	STE lead time, STE active to clock	UCSTEM = 1, UCMODEx = 01 or 10	3.0 V	1		UCxCLK cycles
t _{STE,LAG}	STE lag time, Last clock to STE inactive	UCSTEM = 1, UCMODEx = 01 or 10	3.0 V	1		UCxCLK cycles
t _{SU,MI}	SOMI input data setup time		2.0 V	53		ns
			3.0 V	35		
t _{HD,MI}	SOMI input data hold time		2.0 V	0		ns
			3.0 V	0		
t _{VALID,MO}	SIMO output data valid time ⁽²⁾	UCLK edge to SIMO valid, C _L = 20 pF	2.0 V		20	ns
			3.0 V		20	
t _{HD,MO}	SIMO output data hold time ⁽³⁾	C _L = 20 pF	2.0 V	0		ns
			3.0 V	0		

- (1) $f_{UCxCLK} = 1/2(t_{LO/Hi})$ with $t_{LO/Hi} = \max(t_{VALID,MO(eUSCI)} + t_{SU,SI(Slave)}, t_{SU,MI(eUSCI)} + t_{VALID,SO(Slave)})$
For the slave parameters $t_{SU,SI(Slave)}$ and $t_{VALID,SO(Slave)}$, see the SPI parameters of the attached slave.
- (2) Specifies the time to drive the next valid data to the SIMO output after the output changing UCLK clock edge. See the timing diagrams in Figure 5-10 and Figure 5-11.
- (3) Specifies how long data on the SIMO output is valid after the output changing UCLK clock edge. Negative values indicate that the data on the SIMO output can become invalid before the output changing clock edge observed on UCLK. See the timing diagrams in Figure 5-10 and Figure 5-11.

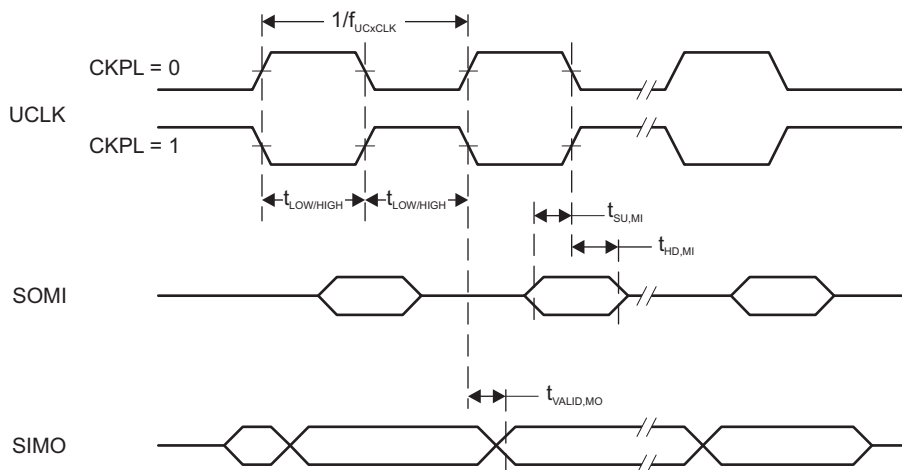

Figure 5-10. SPI Master Mode, CKPH = 0

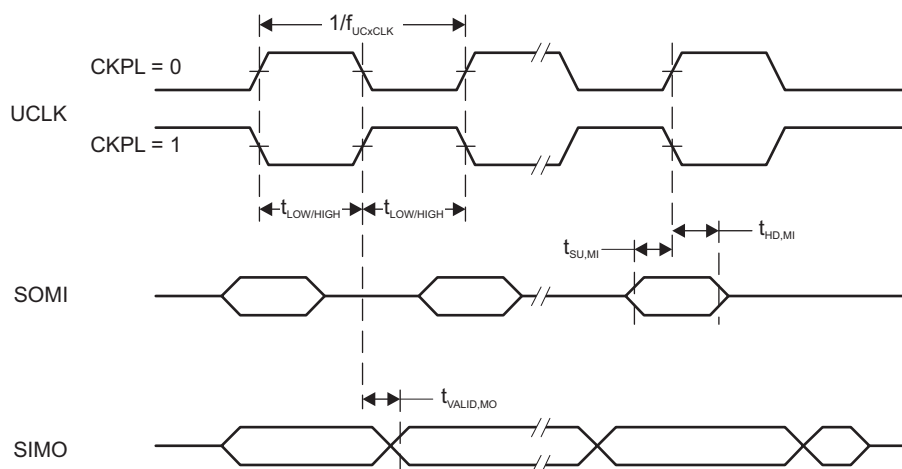

Figure 5-11. SPI Master Mode, CKPH = 1

Table 5-17 lists the switching characteristics of the eUSCI in SPI slave mode.

Table 5-17. eUSCI (SPI Slave Mode) Switching Characteristics

over recommended ranges of supply voltage and operating free-air temperature (unless otherwise noted)⁽¹⁾

PARAMETER		TEST CONDITIONS	V _{CC}	MIN	MAX	UNIT
t _{STE,LEAD}	STE lead time, STE active to clock		2.0 V	55		ns
			3.0 V	45		
t _{STE,LAG}	STE lag time, last clock to STE inactive		2.0 V	20		ns
			3.0 V	20		
t _{STE,ACC}	STE access time, STE active to SOMI data out		2.0 V		65	ns
			3.0 V		40	
t _{STE,DIS}	STE disable time, STE inactive to SOMI high impedance		2.0 V		50	ns
			3.0 V		35	
t _{SU,SI}	SIMO input data setup time		2.0 V	10		ns
			3.0 V	8		
t _{HD,SI}	SIMO input data hold time		2.0 V	12		ns
			3.0 V	12		
t _{VALID,SO}	SOMI output data valid time ⁽²⁾	UCLK edge to SOMI valid, C _L = 20 pF	2.0 V		68	ns
			3.0 V		42	
t _{HD,SO}	SOMI output data hold time ⁽³⁾	C _L = 20 pF	2.0 V	5		ns
			3.0 V	5		

(1) $f_{UCxCLK} = 1/2t_{LO/HI}$ with $t_{LO/HI} \geq \max(t_{VALID,MO(Master)} + t_{SU,SI(eUSCI)}, t_{SU,MI(Master)} + t_{VALID,SO(eUSCI)})$

For the master parameters $t_{SU,MI(Master)}$ and $t_{VALID,MO(Master)}$, see the SPI parameters of the attached master.

- (2) Specifies the time to drive the next valid data to the SOMI output after the output changing UCLK clock edge. See the timing diagrams in [Figure 5-12](#) and [Figure 5-13](#).
- (3) Specifies how long data on the SOMI output is valid after the output changing UCLK clock edge. See the timing diagrams in [Figure 5-12](#) and [Figure 5-13](#).

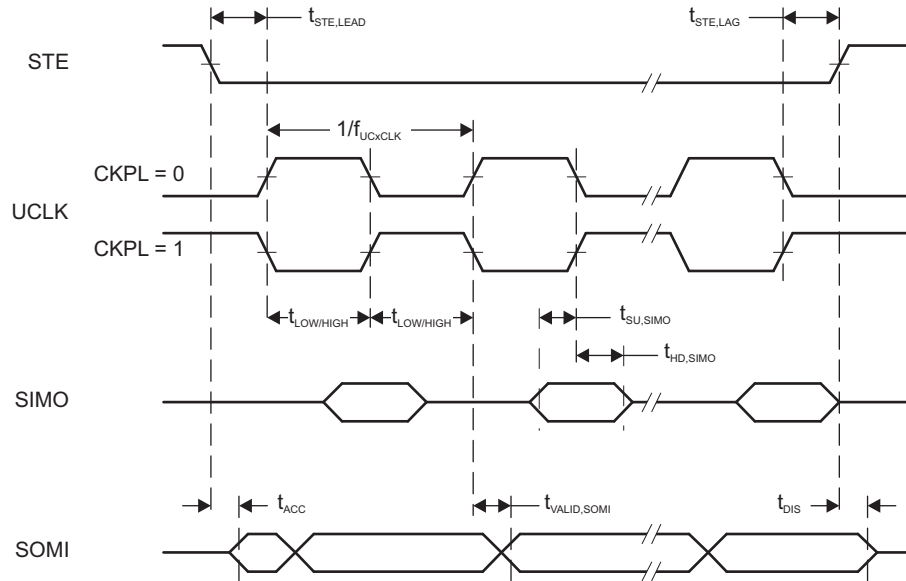

Figure 5-12. SPI Slave Mode, CKPH = 0

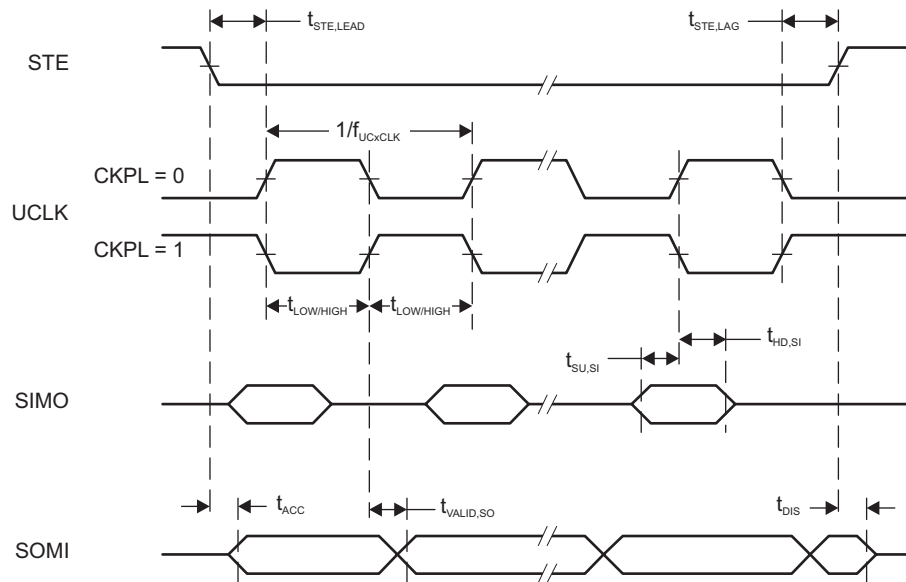

Figure 5-13. SPI Slave Mode, CKPH = 1

5.13.8 ADC

NOTE

The ADC is not available on the MSP430FR2000 device.

Table 5-18 lists the input conditions of the ADC.

Table 5-18. ADC, Power Supply and Input Range Conditions

Over operating free-air temperature range (unless otherwise noted)

PARAMETER		TEST CONDITIONS	V _{CC}	MIN	TYP	MAX	UNIT
DV _{CC}	ADC supply voltage			2.0		3.6	V
V _(Ax)	Analog input voltage range	All ADC pins		0		DV _{CC}	V
I _{ADC}	Operating supply current into DV _{CC} terminal, reference current not included, repeat-single-channel mode	f _{ADCCLK} = 5 MHz, ADCON = 1, REFON = 0, SHT0 = 0, SHT1 = 0, ADCDIV = 0, ADCCONSEQx = 10b	2 V		185		μA
			3 V		207		
C _I	Input capacitance	Only one terminal Ax can be selected at one time from the pad to the ADC capacitor array, including wiring and pad	2.2 V		2.5	3.5	pF
R _I	Input MUX ON resistance	DV _{CC} = 2 V, 0 V = V _{Ax} = DV _{CC}				2	kΩ

Table 5-19 lists the timing parameters of the ADC.

Table 5-19. ADC, 10-Bit Timing Parameters

Over operating free-air temperature range (unless otherwise noted)

PARAMETER		TEST CONDITIONS	V _{CC}	MIN	TYP	MAX	UNIT
f _{ADCCLK}		For specified performance of ADC linearity parameters	2 V to 3.6 V	0.45	5	5.5	MHz
f _{ADCOSC}	Internal ADC oscillator (MODOSC)	ADCDIV = 0, f _{ADCCLK} = f _{ADCOSC}	2 V to 3.6 V	3.8	4.8	5.8	MHz
t _{CONVERT}	Conversion time	REFON = 0, Internal oscillator, 10 ADCCLK cycles, 10-bit mode, f _{ADCOSC} = 4.5 MHz to 5.5 MHz	2 V to 3.6 V	2.18		2.67	μs
t _{ADCON}	Turnon settling time of the ADC	The error in a conversion started after t _{ADCON} is less than ±0.5 LSB. Reference and input signal are already settled.				100	ns
t _{Sample}	Sampling time	R _S = 1000 Ω, R _I = 36000 Ω, C _I = 3.5 pF. Approximately 8 Tau (t) are required for an error of less than ±0.5 LSB.	2 V	1.5			μs
			3 V	2.0			

Table 5-20 lists the linearity parameters of the ADC.

Table 5-20. ADC, 10-Bit Linearity Parameters

Over operating free-air temperature range (unless otherwise noted)

PARAMETER		TEST CONDITIONS	V _{CC}	MIN	TYP	MAX	UNIT
E _I	Integral linearity error (10-bit mode)	V _{ref+} reference	2.4 V to 3.6 V	-2		2	LSB
	Integral linearity error (8-bit mode)		2.0 V to 3.6 V	-2		2	
E _D	Differential linearity error (10-bit mode)	V _{ref+} reference	2.4 V to 3.6 V	-1		1	LSB
	Differential linearity error (8-bit mode)		2.0 V to 3.6 V	-1		1	
E _O	Offset error (10-bit mode)	V _{ref+} reference	2.4 V to 3.6 V	-6.5		6.5	mV
	Offset error (8-bit mode)		2.0 V to 3.6 V	-6.5		6.5	
E _G	Gain error (10-bit mode)	V _{ref+} as reference	2.4 V to 3.6 V	-2.0		2.0	LSB
		Internal 1.5-V reference		-3.0%		3.0%	
	Gain error (8-bit mode)	V _{ref+} as reference	2.0 V to 3.6 V	-2.0		2.0	LSB
		Internal 1.5-V reference		-3.0%		3.0%	
E _T	Total unadjusted error (10-bit mode)	V _{ref+} as reference	2.4 V to 3.6 V	-2.0		2.0	LSB
		Internal 1.5-V reference		-3.0%		3.0%	
	Total unadjusted error (8-bit mode)	V _{ref+} as reference	2.0 V to 3.6 V	-2.0		2.0	LSB
		Internal 1.5-V reference		-3.0%		3.0%	
V _{SENSOR}	See ⁽¹⁾	ADCON = 1, INCH = 0Ch, T _A = 0°C	3.0 V		913		mV
TC _{SENSOR}	See ⁽²⁾	ADCON = 1, INCH = 0Ch	3.0 V		3.35		mV/°C
t _{SENSOR} (sample)	Sample time required if channel 12 is selected	ADCON = 1, INCH = 0Ch, Error of conversion result ≤1 LSB, AM and all LPMs above LPM3	3.0 V		30		μs
		ADCON = 1, INCH = 0Ch, Error of conversion result ≤1 LSB, LPM3	3.0 V		100		

(1) The temperature sensor offset can vary significantly. TI recommends a single-point calibration to minimize the offset error of the built-in temperature sensor.

(2) The device descriptor structure contains calibration values for 30°C ±3°C and 85°C ±3°C for each available reference voltage level. The sensor voltage can be computed as $V_{SENSE} = TC_{SENSOR} \times (\text{Temperature, } ^\circ\text{C}) + V_{SENSOR}$, where TC_{SENSOR} and V_{SENSOR} can be computed from the calibration values for higher accuracy.

5.13.9 Enhanced Comparator (eCOMP)

Table 5-21 lists the characteristics of the eCOMP.

Table 5-21. eCOMP

over recommended ranges of supply voltage and operating free-air temperature (unless otherwise noted)

PARAMETER		TEST CONDITIONS	V _{CC}	MIN	TYP	MAX	UNIT
V _{CC}	Supply voltage			2.0		3.6	V
V _{IC}	Common-mode input range			0		V _{CC}	V
V _{HYS}	DC input hysteresis	CPEN = 1, CPHSEL = 00	2.0 V to 3.6 V		0		mV
		CPEN = 1, CPHSEL = 01		10			
		CPEN = 1, CPHSEL = 10		20			
		CPEN = 1, CPHSEL = 11		30			
V _{OFFSET}	Input offset voltage	CPEN = 1, CPMSEL = 0, CPHSEL = 00	2.0 V to 3.6 V	-40	±5	-40	mV
		CPEN = 1, CPMSEL = 1, CPHSEL = 00		±10			
I _{COMP}	Quiescent current draw from V _{CC} , only comparator	V _{IC} = V _{CC} /2, CPEN = 1, CPMSEL = 0	2.0 V to 3.6 V		22	35	µA
		V _{IC} = V _{CC} /2, CPEN = 1, CPMSEL = 1		1.3	3.5		
I _{DAC}	Quiescent current draw from V _{CC} , only DAC	CPDACREFS = 0, CPEN = 0	2.0 V to 3.6 V		0.5		µA
C _{IN}	Input channel capacitance ⁽¹⁾		2.0 V to 3.6 V		1		pF
R _{IN}	Input channel series resistance	On (switch closed)	2.0 V to 3.6 V		10	20	kΩ
		Off (switch open)		50		MΩ	
t _{PD}	Propagation delay, response time	CPMSEL = 0, CPFLT = 0, Overdrive = 20 mV ⁽²⁾	2.0 V to 3.6 V			1	µs
		CPMSEL = 1, CPFLT = 0, Overdrive = 20 mV ⁽²⁾		2.4			
t _{EN_CP}	Comparator enable time	CPEN = 0→1, CPMSEL = 0, V+ and V- from pads, Overdrive = 20 mV ⁽²⁾	2.0 V to 3.6 V		9.3		µs
		CPEN = 0→1, CPMSEL = 1, V+ and V- from pads, Overdrive = 20 mV ⁽²⁾		12			
t _{EN_CP_DAC}	Comparator with reference DAC enable time	CPEN = 0→1, CPDACEN=0→1, CPMSEL = 0, CPDACREFS = 1, CPDACBUF1 = 0F, Overdrive = 20 mV ⁽²⁾	2.0 V to 3.6 V		9.3		µs
		CPEN = 0→1, CPDACEN=0→1, CPMSEL = 1, CPDACREFS = 1, CPDACBUF1 = 0F, Overdrive = 20 mV ⁽²⁾		113			
t _{FDLY}	Propagation delay with analog filter active	CPMSEL = 0, CPFLTDY = 00, Overdrive = 20 mV, ⁽²⁾ CPFLT = 1	2.0 V to 3.6 V		0.7		µs
		CPMSEL = 0, CPFLTDY = 01, Overdrive = 20 mV, ⁽²⁾ CPFLT = 1		1.1			
		CPMSEL = 0, CPFLTDY = 10, Overdrive = 20 mV, ⁽²⁾ CPFLT = 1		1.9			
		CPMSEL = 0, CPFLTDY = 11, Overdrive = 20 mV, ⁽²⁾ CPFLT = 1		3.7			
V _{CP_DAC}	Reference voltage for built-in 6-bit DAC	V _{IN} = reference into 6-bit DAC, DAC uses internal REF, n = 0 to 63	2.0 V to 3.6 V		V _{IN} × n / 64		V
		V _{IN} = reference into 6-bit DAC, DAC uses V _{CC} as REF, n = 0 to 63		V _{IN} × n / 64			
INL	Integral nonlinearity		2.0 V to 3.6 V	-0.5		+0.5	LSB
DNL	Differential nonlinearity		2.0 V to 3.6 V	-0.5		+0.5	LSB

(1) For the eCOMP C_{IN} model, see Figure 5-14.

(2) This is measured over the input offset.

Table 5-21. eCOMP (continued)

over recommended ranges of supply voltage and operating free-air temperature (unless otherwise noted)

PARAMETER	TEST CONDITIONS	V _{CC}	MIN	TYP	MAX	UNIT
Zero scale		2.0 V to 3.6 V		0		LSB
I _{DACOFF}	Leakage current	2.0 V to 3.6 V		5		nA

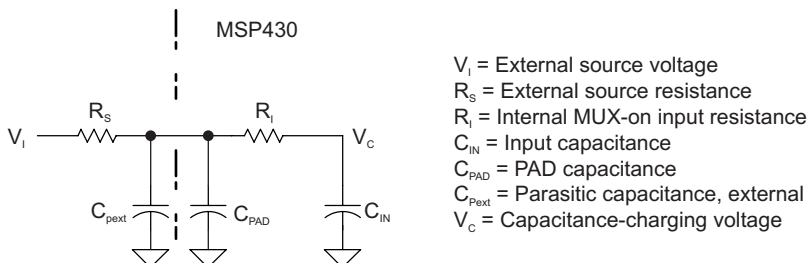

Figure 5-14. eCOMP Input Circuit

5.13.10 FRAM

Table 5-22 lists the characteristics of the FRAM.

Table 5-22. FRAM

over recommended ranges of supply voltage and operating free-air temperature (unless otherwise noted)

PARAMETER	TEST CONDITIONS	MIN	TYP	MAX	UNIT
Read and write endurance		10 ¹⁵			cycles
t _{Retention}	Data retention duration	T _J = 25°C	100		years
		T _J = 70°C	40		
		T _J = 85°C	10		
I _{WRITE}	Current to write into FRAM		I _{READ} ⁽¹⁾		nA
I _{ERASE}	Erase current		n/a ⁽²⁾		
t _{WRITE}	Write time		t _{READ} ⁽³⁾		ns
I _{READ}	Read time, NWAITSx = 0		1 / f _{SYSTEM} ⁽⁴⁾		ns
	Read time, NWAITSx = 1		2 / f _{SYSTEM} ⁽⁴⁾		ns

- (1) Writing to FRAM does not require a setup sequence or additional power when compared to reading from FRAM. The FRAM read current I_{READ} is included in the active mode current consumption I_{AM, FRAM}.
- (2) n/a = not applicable. FRAM does not require a special erase sequence.
- (3) Writing to FRAM is as fast as reading.
- (4) The maximum read (and write) speed is specified by f_{SYSTEM} using the appropriate wait state settings (NWAITSx).

5.13.11 Emulation and Debug

Table 5-23 lists the characteristics of the Spy-Bi-Wire interface.

Table 5-23. JTAG, Spy-Bi-Wire Interface

over recommended ranges of supply voltage and operating free-air temperature (unless otherwise noted) (see Figure 5-15)

PARAMETER		V _{CC}	MIN	TYP	MAX	UNIT
f _{SBW}	Spy-Bi-Wire input frequency	2.0 V, 3.0 V	0		8	MHz
t _{SBW,Low}	Spy-Bi-Wire low clock pulse duration	2.0 V, 3.0 V	0.028		15	µs
t _{SU,SBWTDIO}	SBWTDIO setup time (before falling edge of SBWTCK in TMS and TDI slot Spy-Bi-Wire)	2.0 V, 3.0 V	4			ns
t _{HD,SBWTDIO}	SBWTDIO hold time (after rising edge of SBWTCK in TMS and TDI slot Spy-Bi-Wire)	2.0 V, 3.0 V	19			ns
t _{Valid,SBWTDIO}	SBWTDIO data valid time (after falling edge of SBWTCK in TDO slot Spy-Bi-Wire)	2.0 V, 3.0 V			31	ns
t _{SBW, En}	Spy-Bi-Wire enable time (TEST high to acceptance of first clock edge) (1)	2.0 V, 3.0 V			110	µs
t _{SBW,Ret}	Spy-Bi-Wire return to normal operation time ⁽²⁾	2.0 V, 3.0 V	15		100	µs

- (1) Tools that access the Spy-Bi-Wire interface must wait for the t_{SBW,En} time after pulling the TEST/SBWTCK pin high before applying the first SBWTCK clock edge.
- (2) Maximum t_{SBW,Rst} time after pulling or releasing the TEST/SBWTCK pin low, the Spy-Bi-Wire pins revert from their Spy-Bi-Wire function to their application function. This time applies only if the Spy-Bi-Wire mode was selected.

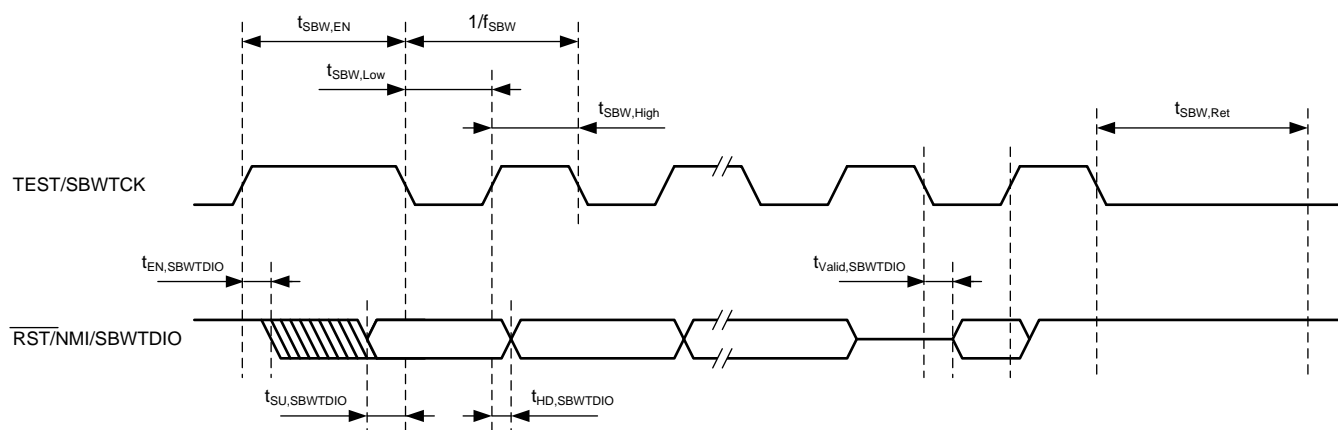

Figure 5-15. JTAG Spy-Bi-Wire Timing

Table 5-24 lists the characteristics of the 4-wire JTAG interface.

Table 5-24. JTAG, 4-Wire Interface

over recommended ranges of supply voltage and operating free-air temperature (unless otherwise noted) (see Figure 5-16)

PARAMETER		V _{CC}	MIN	TYP	MAX	UNIT
f _{TCK}	TCK input frequency ⁽¹⁾	2.0 V, 3.0 V	0		10	MHz
t _{TCK,Low}	TCK low clock pulse duration	2.0 V, 3.0 V	15			ns
t _{TCK,high}	TCK high clock pulse duration	2.0 V, 3.0 V	15			ns
t _{SU,TMS}	TMS setup time (before rising edge of TCK)	2.0 V, 3.0 V	11			ns
t _{HD,TMS}	TMS hold time (after rising edge of TCK)	2.0 V, 3.0 V	3			ns
t _{SU,TDI}	TDI setup time (before rising edge of TCK)	2.0 V, 3.0 V	13			ns
t _{HD,TDI}	TDI hold time (after rising edge of TCK)	2.0 V, 3.0 V	5			ns
t _{z-Valid,TDO}	TDO high impedance to valid output time (after falling edge of TCK)	2.0 V, 3.0 V			26	ns
t _{Valid,TDO}	TDO to new valid output time (after falling edge of TCK)	2.0 V, 3.0 V			26	ns
t _{Valid-Z,TDO}	TDO valid to high-impedance output time (after falling edge of TCK)	2.0 V, 3.0 V			26	ns
t _{JTAG,Ret}	JTAG return to normal operation time		15		100	μs
R _{internal}	Internal pulldown resistance on TEST	2.0 V, 3.0 V	20	35	50	kΩ

(1) Tools that access the Spy-Bi-Wire interface must wait for the t_{SBW,En} time after pulling the TEST/SBWTCK pin high before applying the first SBWTCK clock edge.

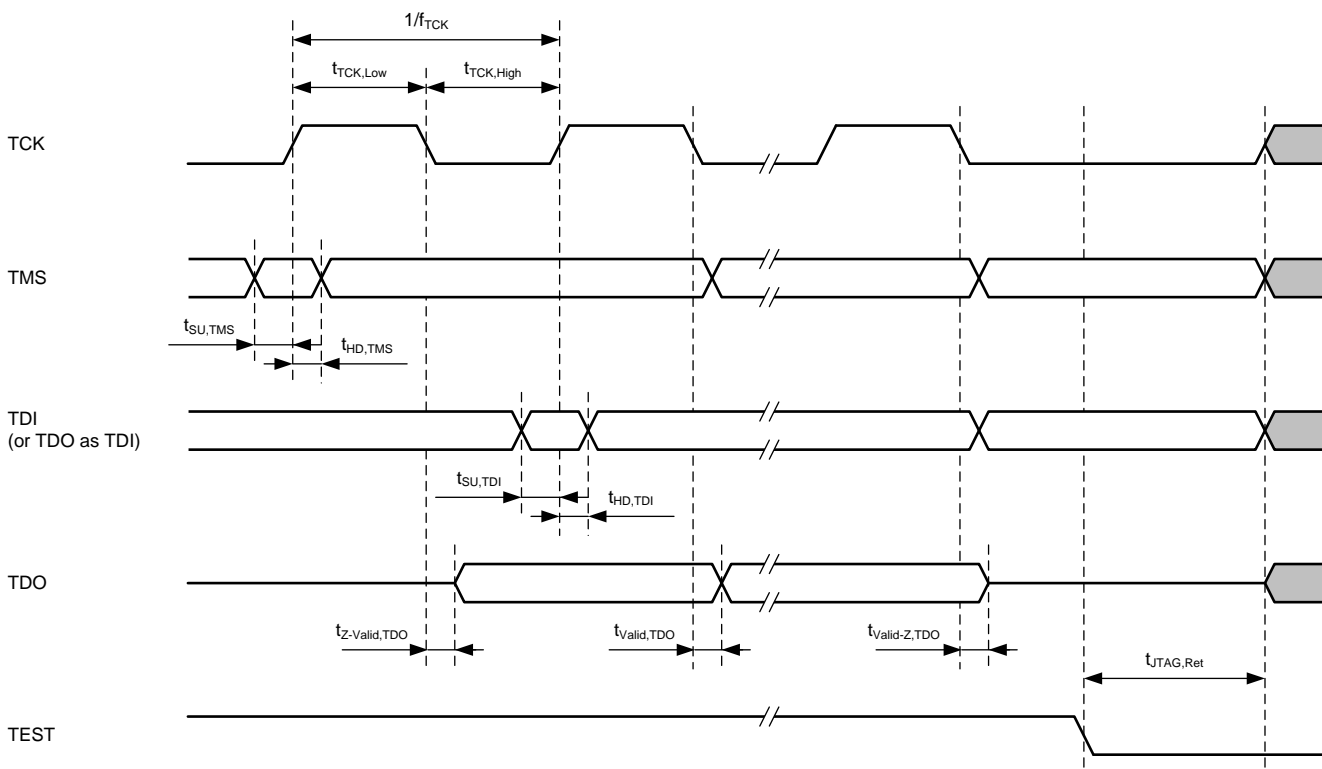

Figure 5-16. JTAG 4-Wire Timing

6 Detailed Description

6.1 Overview

The Texas Instruments MSP430FR211x family of ultra-low-power microcontrollers consists of several devices featuring different sets of peripherals. The architecture, combined with five low-power modes, is optimized to achieve extended battery life (for example, in portable measurement applications). The devices feature a powerful 16-bit RISC CPU, 16-bit register, and constant generators that contribute to maximum code efficiency.

The MSP430FR211x devices are microcontroller configurations with one Timer_B, eCOMP with built-in 6-bit DAC as an internal reference voltage, a high-performance 10-bit ADC, an eUSCI that supports UART and SPI, an RTC module with alarm capabilities, and up to 12 I/O pins.

6.2 CPU

The MSP430 CPU has a 16-bit RISC architecture that is highly transparent to the application. All operations, other than program-flow instructions, are performed as register operations in conjunction with seven addressing modes for source operand and four addressing modes for destination operand.

The CPU is integrated with 16 registers that provide reduced instruction execution time. The register-to-register operation execution time is one cycle of the CPU clock.

Four of the registers, R0 to R3, are dedicated as program counter (PC), stack pointer (SP), status register (SR), and constant generator (CG), respectively. The remaining registers are general-purpose registers.

Peripherals are connected to the CPU using data, address, and control buses. Peripherals can be managed with all instructions.

6.3 Operating Modes

The MSP430 has one active mode and several software selectable low-power modes of operation (see [Table 6-1](#)). An interrupt event can wake up the device from low-power mode LPM0, LPM3 or LPM4, service the request, and restore back to the low-power mode on return from the interrupt program. Low-power modes LPM3.5 and LPM4.5 disable the core supply to minimize power consumption.

NOTE

XT1CLK and VLOCLK can be active during LPM4 if requested by low-frequency peripherals.

Table 6-1. Operating Modes

MODE		AM	LPM0	LPM3	LPM4	LPM3.5	LPM4.5
		ACTIVE MODE	CPU OFF	STANDBY	OFF	ONLY RTC COUNTER	SHUTDOWN
Maximum system clock		16 MHz	16 MHz	40 kHz	0	40 kHz	0
Power consumption at 25°C, 3 V		120 μ A/MHz	40 μ A/MHz	1.5 μ A	0.42 μ A without SVS	0.66 μ A	34 nA without SVS
Wake-up time		N/A	instant	10 μ s	10 μ s	150 μ s	150 μ s
Wake-up events		N/A	All	All	I/O	RTC Counter I/O	I/O
Power	Regulator	Full Regulation	Full Regulation	Partial Power Down	Partial Power Down	Partial Power Down	Power Down
	SVS	On	On	Optional	Optional	Optional	Optional
	Brownout	On	On	On	On	On	On
Clock ⁽¹⁾	MCLK	Active	Off	Off	Off	Off	Off
	SMCLK	Optional	Optional	Off	Off	Off	Off
	FLL	Optional	Optional	Off	Off	Off	Off
	DCO	Optional	Optional	Off	Off	Off	Off
	MODCLK	Optional	Optional	Off	Off	Off	Off
	REFO	Optional	Optional	Optional	Off	Off	Off
	ACLK	Optional	Optional	Optional	Off	Off	Off
	XT1LFCLK	Optional	Optional	Optional	Off	Optional	Off
Core	VLOCLK	Optional	Optional	Optional	Off	Optional	Off
	CPU	On	Off	Off	Off	Off	Off
	FRAM	On	On	Off	Off	Off	Off
	RAM	On	On	On	On	Off	Off
Peripherals	Backup Memory ⁽²⁾	On	On	On	On	On	Off
	Timer_B3	Optional	Optional	Optional	Off	Off	Off
	WDT	Optional	Optional	Optional	Off	Off	Off
	eUSCI_A	Optional	Optional	Optional	Off	Off	Off
	CRC	Optional	Optional	Off	Off	Off	Off
	ADC ⁽³⁾	Optional	Optional	Optional	Off	Off	Off
	eCOMP	Optional	Optional	Optional	Optional	Off	Off
RTC Counter	Optional	Optional	Optional	Off	Optional	Off	
I/O	General Digital Input/Output	On	Optional	State Held	State Held	State Held	State Held
	Capacitive Touch I/O	Optional	Optional	Optional	Off	Off	Off

(1) The status shown for LPM4 applies to internal clocks only.

(2) Backup memory contains 32 bytes of register space in the peripheral memory. See [Table 6-18](#) and [Table 6-31](#) for its memory allocation.

(3) The ADC is not available on the MSP430FR2000 device.

6.4 Interrupt Vector Addresses

The interrupt vectors and the power-up start address are in the address range 0FFFFh to 0FF80h. The vector contains the 16-bit address of the appropriate interrupt-handler instruction sequence. [Table 6-2](#) summarizes the interrupts sources, flags, and vectors.

Table 6-2. Interrupt Sources, Flags, and Vectors

INTERRUPT SOURCE	INTERRUPT FLAG	SYSTEM INTERRUPT	WORD ADDRESS	PRIORITY
System Reset Power up, brownout, supply supervisor External reset RST Watchdog time-out, key violation FRAM uncorrectable bit error detection Software POR, BOR FLL unlock error	SVSHIFG PMMRSTIFG WDTIFG PMMPORIFG, PMMBORIFG SYSRSTIV FLLULPUC	Reset	FFFEh	63, Highest
System NMI Vacant memory access JTAG mailbox FRAM access time error FRAM bit error detection	VMAIFG JMBINIFG, JMBOUTIFG CBDIFG, UBDIFG	(Non)maskable	FFFCh	62
User NMI External NMI Oscillator fault	NMIIFG OFIFG	(Non)maskable	FFFAh	61
Timer0_B3	TB0CCR0 CCIFG0	Maskable	FFF8h	60
Timer0_B3	TB0CCR1 CCIFG1, TB0CCR2 CCIFG2, TB0IFG (TB0IV)	Maskable	FFF6h	59
RTC counter	RTCIFG	Maskable	FFF4h	58
Watchdog timer interval mode	WDTIFG	Maskable	FFF2h	57
eUSCI_A0 receive or transmit	UCTXCFIFG, UCSTTIFG, UCRXIFG, UCTXIFG (UART mode) UCRXIFG, UCTXIFG (SPI mode) (UCA0IV)	Maskable	FFF0h	56
ADC	ADCIFG0, ADCINIFG, ADCLOIFG, ADCHIIFG, ADCTOVIFG, ADCOVIFG (ADCIV)	Maskable	FFEEh	55
P1	P1IFG.0 to P1IFG.3 (P1IV)	Maskable	FFECh	54
P2	P2IFG.0, P2IFG.1, P2IFG.6 and P2IFG.7 (P2IV)	Maskable	FFEAh	53
eCOMP0	CPIIFG, CPIFG (CPIV)	Maskable	FFE8h	52
Reserved	Reserved	Maskable	FFE6h to FF88h	
Signatures	BSL Signature 2		0FF86h	
	BSL Signature 1		0FF84h	
	JTAG Signature 2		0FF82h	
	JTAG Signature 1		0FF80h	

6.5 Memory Organization

Table 6-3 summarizes the memory map of the MSP430FR211x and MSP430FR210x devices.

Table 6-3. Memory Organization

MEMORY TYPE	ACCESS	MSP430FR2111	MSP430FR2110	MSP430FR2100	MSP430FR2000
Memory (FRAM) Main: interrupt vectors and signatures Main: code memory	Read/write (optional write protect) ⁽¹⁾	3.75KB FFFFh to FF80h FFFFh to F100h	2KB FFFFh to FF80h FFFFh to F800h	1KB FFFFh to FF80h FFFFh to FC00h	0.5KB FFFFh to FF80h FFFFh to FE00h
RAM	Read/write	1KB 23FFh to 2000h	1KB 23FFh to 2000h	512 bytes 21FFh to 2000h	512 bytes 21FFh to 2000h
Bootloader (BSL) memory (ROM) (TI internal use)	Read only	1KB 13FFh to 1000h	1KB 13FFh to 1000h	1KB 13FFh to 1000h	1KB 13FFh to 1000h
Peripherals	Read/write	4KB 0FFFh to 0000h	4KB 0FFFh to 0000h	4KB 0FFFh to 0000h	4KB 0FFFh to 0000h

(1) The Program FRAM can be write protected by setting the PFWP bit in the SYSCFG0 register. See the SYS chapter in the [MSP430FR4xx and MSP430FR2xx Family User's Guide](#) for more details.

6.6 Bootloader (BSL)

The BSL lets users program the FRAM or RAM using a UART interface. Access to the device memory through the BSL is protected by an user-defined password. Table 6-4 lists the BSL pin requirements. BSL entry requires a specific entry sequence on the $\overline{\text{RST}}/\text{NMI}/\text{SBWTDIO}$ and $\text{TEST}/\text{SBWTCK}$ pins. For a complete description of the features of the BSL and its implementation, see the [MSP430 FRAM Device Bootloader \(BSL\) User's Guide](#).

Table 6-4. UART BSL Pin Requirements and Functions

DEVICE SIGNAL	BSL FUNCTION
$\overline{\text{RST}}/\text{NMI}/\text{SBWTDIO}$	Entry sequence signal
$\text{TEST}/\text{SBWTCK}$	Entry sequence signal
P1.7	Data transmit
P1.6	Data receive
DVCC	Power supply
DVSS	Ground supply

6.7 JTAG Standard Interface

The MSP430 family supports the standard JTAG interface, which requires four signals for sending and receiving data. The JTAG signals are shared with general-purpose I/Os. The $\text{TEST}/\text{SBWTCK}$ pin is used to enable the JTAG signals. The $\overline{\text{RST}}/\text{NMI}/\text{SBWTDIO}$ pin is also required to interface with MSP430 development tools and device programmers. Table 6-5 lists the JTAG pin requirements. For details on interfacing to development tools and device programmers, see the [MSP430 Hardware Tools User's Guide](#).

Table 6-5. JTAG Pin Requirements and Function

DEVICE SIGNAL	DIRECTION	JTAG FUNCTION
P1.4/UCA0STE/TCK/A4	IN	JTAG clock input
P1.5/UCA0CLK/TMS/A5	IN	JTAG state control
P1.6/UCA0RXD/UCA0SOMI/TB0.1/TDI/TCLK/A6	IN	JTAG data input, TCLK input
P1.7/UCA0TXD/UCA0SIMO/TB0.2/TDO/A7/VREF+	OUT	JTAG data output
$\text{TEST}/\text{SBWTCK}$	IN	Enable JTAG pins
$\overline{\text{RST}}/\text{NMI}/\text{SBWTDIO}$	IN	External reset
DVCC	–	Power supply
DVSS	–	Ground supply

6.8 Spy-Bi-Wire Interface (SBW)

The MSP430 family supports the 2-wire Spy-Bi-Wire interface. Spy-Bi-Wire can be used to interface with MSP430 development tools and device programmers. [Table 6-6](#) lists the Spy-Bi-Wire interface pin requirements. For further details on interfacing to development tools and device programmers, see the [MSP430 Hardware Tools User's Guide](#).

Table 6-6. Spy-Bi-Wire Pin Requirements and Functions

DEVICE SIGNAL	DIRECTION	SBW FUNCTION
TEST/SBWTCK	IN	Spy-Bi-Wire clock input
RST/NMI/SBWDIO	IN, OUT	Spy-Bi-Wire data input and output
VCC		Power supply
VSS		Ground supply

6.9 FRAM

The FRAM can be programmed using the JTAG port, Spy-Bi-Wire (SBW), the BSL, or in-system by the CPU. Features of the FRAM include:

- Byte and word access capability
- Programmable wait state generation
- Error correction coding (ECC)

6.10 Memory Protection

The device features memory protection of user access authority and write protection include:

- Securing the whole memory map to prevent unauthorized access from JTAG port or BSL, by writing JTAG and BSL signatures using the JTAG port, SBW, the BSL, or in-system by the CPU.
- Write protection enabled to prevent unwanted write operation to FRAM contents by setting the control bits with accordingly password in System Configuration register 0. For more detailed information, see the SYS chapter in the [MSP430FR4xx and MSP430FR2xx Family User's Guide](#).

6.11 Peripherals

Peripherals are connected to the CPU through data, address, and control buses. All peripherals can be handled by using all instructions in the memory map. For complete module description, see the [MSP430FR4xx and MSP430FR2xx Family User's Guide](#).

6.11.1 Power-Management Module (PMM) and On-Chip Reference Voltages

The PMM includes an integrated voltage regulator that supplies the core voltage to the device. The PMM also includes supply voltage supervisor (SVS) and brownout protection. The brownout reset circuit (BOR) is implemented to provide the proper internal reset signal to the device during power on and power off. The SVS circuitry detects if the supply voltage drops below a user-selectable safe level. SVS circuitry is available on the primary supply.

The device contains two on-chip references: 1.5 V for internal reference and 1.2 V for external reference.

The 1.5-V reference is internally connected to ADC channel 13. DVCC is internally connected to ADC channel 15. When DVCC is set as the reference voltage for ADC conversion, the DVCC can be easily represent as [Equation 1](#) by using the ADC sampling the 1.5-V reference without any external components support.

$$DVCC = (1023 \times 1.5 \text{ V}) / 1.5\text{-V Reference ADC result} \quad (1)$$

The 1.5-V reference is also internally connected to the comparator built-in DAC as reference voltage. DVCC is internally connected to another source of the DAC reference, and both are controlled by the CPDACREFS bit. For more detailed information, see the Comparator chapter of the [MSP430FR4xx and MSP430FR2xx Family User's Guide](#).

A 1.2-V reference voltage can be buffered and output to P1.7/TDO/A7/VREF+, when EXTREFEN = 1 in the PMMCTL2 register. ADC channel 7 can also be selected to monitor this voltage. For more detailed information, see the [MSP430FR4xx and MSP430FR2xx Family User's Guide](#).

NOTE

The ADC is not available on the MSP430FR2000 device.

6.11.2 Clock System (CS) and Clock Distribution

The clock system includes a 32-kHz low-frequency oscillator (XT1), an internal very-low-power low-frequency oscillator (VLO), an integrated 32-kHz RC oscillator (REFO), an integrated internal digitally controlled oscillator (DCO) that may use frequency-locked loop (FLL) locking with an internal or external 32-kHz reference clock, and on-chip asynchronous high-speed clock (MODOSC). The clock system is designed to target cost-effective designs with minimal external components. A fail-safe mechanism is designed for XT1. The clock system module offers the following clock signals.

- Main Clock (MCLK): the system clock used by the CPU and all relevant peripherals accessed by the bus. All clock sources except MODOSC can be selected as the source with a predivider of 1, 2, 4, 8, 16, 32, 64, or 128.
- Sub-Main Clock (SMCLK): the subsystem clock used by the peripheral modules. SMCLK derives from the MCLK with a predivider of 1, 2, 4, or 8. This means SMCLK is always equal to or less than MCLK.
- Auxiliary Clock (ACLK): this clock is derived from the external XT1 clock or internal REFO clock up to 40 kHz.

All peripherals may have one or several clock sources depending on specific functionality. [Table 6-7](#) and [Table 6-8](#) summarize the clock distribution used in this device.

Table 6-7. Clock Distribution

	CLOCK SOURCE SELECT BITS	MCLK	SMCLK	ACLK	MODCLK	VLOCLK	EXTERNAL PIN
Frequency Range		DC to 16 MHz	DC to 16 MHz	DC to 40 kHz	4 MHz	10 kHz	
CPU	N/A	Default					
FRAM	N/A	Default					
RAM	N/A	Default					
CRC	N/A	Default					
I/O	N/A	Default					
TB0	TBSSEL		10b	01b			00b (TB0CLK pin)
eUSCI_A0	UCSSEL		10b or 11b	01b			00b (UCA0CLK pin)
WDT	WDTSEL		00b	01b		10b	
ADC ⁽¹⁾	ADCSEL		10b or 11b	01b	00b		
RTC	RTCSS		01b ⁽²⁾	01b ⁽²⁾		11b	

(1) The ADC is not available on the MSP430FR2000 device.

(2) Controlled by the RTCCKSEL bit in the SYSCFG2 register.

Table 6-8. XTCLK Distribution

OPERATION MODE	CLOCK SOURCE SELECT BITS	XTLFCLK
		AM TO LPM3.5 (DC to 40 kHz)
MCLK	SEMS	10b
SMCLK	SEMS	10b
REFO	SELREF	0b
ACLK	SELA	0b
RTC	RTCSS	10b

6.11.3 General-Purpose Input/Output Port (I/O)

Up to 12 I/O ports are implemented.

- P1 has 8 bits implemented, and P2 has 4 bits implemented.
- All individual I/O bits are independently programmable.
- Any combination of input, output, and interrupt conditions is possible to P1 and P2.
- Programmable pullup or pulldown on all ports.
- Edge-selectable interrupt, LPM4, LPM3.5 and LPM4.5 wake-up input capability is available for P1.0 to P1.3, P2.0, P2.1, P2.6, and P2.7.
- Read and write access to port-control registers is supported by all instructions.
- Ports can be accessed byte-wise or word-wise in pairs.
- Capacitive Touch I/O functionality is supported on all pins.

NOTE

Configuration of digital I/Os after BOR reset

To prevent any cross currents during start-up of the device, all port pins are high-impedance with Schmitt triggers and module functions disabled. To enable the I/O functions after a BOR reset, the ports must be configured first and then the LOCKLPM5 bit must be cleared. For details, see the *Configuration After Reset* section in the Digital I/O chapter of the [MSP430FR4xx and MSP430FR2xx Family User's Guide](#).

6.11.4 Watchdog Timer (WDT)

The primary function of the WDT module is to perform a controlled system restart after a software problem occurs. If the selected time interval expires, a system reset is generated. If the watchdog function is not needed in an application, the module can be configured as interval timer and can generate interrupts at selected time intervals.

Table 6-9. WDT Clocks

WDTSEL	NORMAL OPERATION (WATCHDOG AND INTERVAL TIMER MODE)
00	SMCLK
01	ACLK
10	VLOCLK
11	Reserved

6.11.5 System Module (SYS)

The SYS module handles many of the system functions within the device. These system functions include power-on reset (POR) and power-up clear (PUC) handling, NMI source selection and management, reset interrupt vector generators, bootloader entry mechanisms, and configuration management (device descriptors). SYS also includes a data exchange mechanism through SBW called a JTAG mailbox that can be used in the application. [Table 6-10](#) lists the SYS module interrupt vector registers.

Table 6-10. System Module Interrupt Vector Registers

INTERRUPT VECTOR REGISTER	ADDRESS	INTERRUPT EVENT	VALUE	PRIORITY
SYSRSTIV, System Reset	015Eh	No interrupt pending	00h	
		Brownout (BOR)	02h	Highest
		RSTIFGRST/NMI (BOR)	04h	
		PMMSWBOR software BOR (BOR)	06h	
		LPMx.5 wakeup (BOR)	08h	
		Security violation (BOR)	0Ah	
		Reserved	0Ch	
		SVSHIFG SVSH event (BOR)	0Eh	
		Reserved	10h	
		Reserved	12h	
		PMMSWPOR software POR (POR)	14h	
		WDTIFG watchdog time-out (PUC)	16h	
		WDTPW password violation (PUC)	18h	
		FRCTLPW password violation (PUC)	1Ah	
		Uncorrectable FRAM bit error detection	1Ch	
		Peripheral area fetch (PUC)	1Eh	
		PMMPW PMM password violation (PUC)	20h	
		Reserved	22h	
		FLL unlock (PUC)	24h	
Reserved	26h to 3Eh	Lowest		
SYSSNIV, System NMI	015Ch	No interrupt pending	00h	
		SVS low-power reset entry	02h	Highest
		Uncorrectable FRAM bit error detection	04h	
		Reserved	06h	
		Reserved	08h	
		Reserved	0Ah	
		Reserved	0Ch	
		Reserved	0Eh	
		Reserved	10h	
		VMAIFG Vacant memory access	12h	
		JMBINIFG JTAG mailbox input	14h	
		JMBOUTIFG JTAG mailbox output	16h	
		Correctable FRAM bit error detection	18h	
		Reserved	1Ah to 1Eh	Lowest
		SYSUNIV, User NMI	015Ah	No interrupt pending
NMIIFG NMI pin or SVS _H event	02h			Highest
OFIFG oscillator fault	04h			
Reserved	06h to 1Eh			Lowest

6.11.6 Cyclic Redundancy Check (CRC)

The 16-bit CRC module produces a signature based on a sequence of data values and can be used for data checking purposes. The CRC generation polynomial is compliant with CRC-16-CCITT standard of $x^{16} + x^{12} + x^5 + 1$.

6.11.7 Enhanced Universal Serial Communication Interface (eUSCI_A0)

The eUSCI modules are used for serial data communications. The eUSCI_A module supports either UART or SPI communications. Additionally, eUSCI_A supports automatic baud-rate detection and IrDA.

Table 6-11. eUSCI Pin Configurations

eUSCI_A0	PIN (USCIARMP = 0)	UART	SPI
	P1.7	TXD	SIMO
	P1.6	RXD	SOMI
	P1.5		SCLK
	P1.4		STE
	PIN (USCIARMP = 1)	UART	SPI
	P1.3 ⁽¹⁾	TXD	SIMO
	P1.2 ⁽¹⁾	RXD	SOMI
	P1.1 ⁽¹⁾		SCLK
	P1.0 ⁽¹⁾		STE

(1) This is the remapped functionality controlled by the USCIARMP bit in the SYSCFG3 register. Only one selected port is valid at the same time.

6.11.8 Timers (Timer0_B3)

The Timer0_B3 module is 16-bit timer and counter with three capture/compare registers. The timer can support multiple captures or compares, PWM outputs, and interval timing (see [Table 6-12](#)). Timer0_B3 has extensive interrupt capabilities. Interrupts may be generated from the counter on overflow conditions and from each of the capture/compare registers. The CCR0 register on Timer0_B3 is not externally connected and can be used only for hardware period timing and interrupt generation. In Up Mode, it can be used to set the overflow value of the counter.

Table 6-12. Timer0_B3 Signal Connections

PORT PIN	DEVICE INPUT SIGNAL	MODULE INPUT NAME	MODULE BLOCK	MODULE OUTPUT SIGNAL	DEVICE OUTPUT SIGNAL	
P2.7	TB0CLK	TBCLK	Timer	N/A		
	ACLK (internal)	ACLK				
	SMCLK (internal)	SMCLK				
	From Capacitive Touch I/O (internal)	INCLK				
	From RTC (internal)	CCI0A	CCR0	TB0		
	ACLK (internal)	CCI0B				
	DVSS	GND				
	DVCC	VCC				
P1.6 (TBRMP = 0)	TB0.1	CCI1A	CCR1	TB1	TB0.1	
P2.0 (TBRMP = 1) ⁽¹⁾		From eCOMP (internal)			CCI1B	To ADC trigger ⁽²⁾
		DVSS			GND	
		DVCC			VCC	
P1.7 (TBRMP = 0)	TB0.2	CCI2A	CCR2	TB2	TB0.2	
P2.1 (TBRMP = 1) ⁽¹⁾		From Capacitive Touch I/O (internal)			CCI2B	
		DVSS			GND	
		DVCC			VCC	

(1) This is the remapped functionality controlled by the TBRMP bit in the SYSCFG3 register. Only one selected port is valid at the same time when TB0 acts as capture input functionality. TB0 PWM outputs regardless of the setting on this remap bit.

(2) The ADC is not available on the MSP430FR2000 device.

The interconnection of Timer0_B3 can be used to modulate the eUSCI_A pin of UCA0TXD/UCA0SIMO in either ASK or part of FSK mode, with which a user can easily acquire a modulated infrared command for directly driving an external IR diode. The IR functions are fully controlled by SYSCFG1 including IREN (enable), IRPSEL (polarity select), IRMSEL (mode select), IRDSEL (data select), and IRDATA (data) bits. For more information, see the SYS chapter in the [MSP430FR4xx and MSP430FR2xx Family User's Guide](#).

The Timer_B module can put all Timer_B outputs into a high-impedance state when the selected source is triggered. The source can be selected from external pin or internal of the device, which is controlled by TB0TRG in SYS. For more information, see the SYS chapter in the [MSP430FR4xx and MSP430FR2xx Family User's Guide](#).

Table 6-13 summarizes the selection of the Timer_B high-impedance trigger.

Table 6-13. TBxOUTH

TB0TRGSEL	TB0OUTH TRIGGER SOURCE SELECTION	Timer_B PAD OUTPUT HIGH IMPEDANCE
TB0TRGSEL = 0	eCOMP0 output (internal)	P1.6, P1.7, P2.0, P2.1 ⁽¹⁾
TB0TRGSEL = 1	P1.2	

(1) When TB0 is set to PWM output function, both port groups can receive the output, and the output is controlled by only the PxSEL.y bits.

6.11.9 Backup Memory (BAKMEM)

The BAKMEM supports data retention functionality during LPM3.5 mode. This device provides up to 32 bytes that are retained during LPM3.5.

6.11.10 Real-Time Clock (RTC) Counter

The RTC counter is a 16-bit modulo counter that is functional in AM, LPM0, LPM3, LPM4, and LPM3.5. This module may periodically wake up the CPU from LPM0, LPM3, LPM4, or LPM3.5 based on timing from a low-power clock source such as XT1, ACLK, or VLO. In AM, RTC can be driven by SMCLK to generate high-frequency timing events and interrupts. ACLK and SMCLK both can source to the RTC; however, only one of them can be selected at any given time. The RTC overflow events trigger:

- Timer0_B3 CCR0A
- ADC conversion trigger when ADCSHSx bits are set as 01b

6.11.11 10-Bit Analog-to-Digital Converter (ADC)

The 10-bit ADC module supports fast 10-bit analog-to-digital conversions with single-ended input. The module implements a 10-bit SAR core, sample select control, reference generator, and a conversion result buffer. A window comparator with lower and upper limits allows CPU-independent result monitoring with three window comparator interrupt flags.

NOTE

The ADC is not available on the MSP430FR2000 device.

The ADC supports 10 external inputs and 4 internal inputs (see [Table 6-14](#)).

Table 6-14. ADC Channel Connections

ADCSHSx	ADC CHANNELS	EXTERNAL PIN OUT
0	A0/Veref+	P1.0
1	A1/	P1.1
2	A2/Veref-	P1.2
3	A3	P1.3
4	A4	P1.4
5	A5	P1.5
6	A6	P1.6
7	A7 ⁽¹⁾	P1.7
8	Not used	N/A
9	Not used	N/A
10	Not used	N/A
11	Not used	N/A
12	On-chip temperature sensor	N/A
13	Reference voltage (1.5 V)	N/A
14	DVSS	N/A
15	DVCC	N/A

(1) When A7 is used, the PMM 1.2-V reference voltage can be output to this pin by setting the PMM control register. The 1.2-V voltage can be directly measured by A7 channel.

The conversion can be started by software or a hardware trigger. [Table 6-15](#) lists the trigger sources that are available.

Table 6-15. ADC Trigger Signal Connections

ADCSHSx		TRIGGER SOURCE
BINARY	DECIMAL	
00	0	ADCSC bit (software trigger)
01	1	RTC event
10	2	TB0.1B
11	3	eCOMP0 COUT

6.11.12 eCOMP0

The enhanced comparator is an analog voltage comparator with built-in 6-bit DAC as an internal voltage reference. The integrated 6-bit DAC can be set up to 64 steps for comparator reference voltage. This module has 4-level programmable hysteresis and a configurable power mode: high-power or low-power mode.

The eCOMP0 supports external inputs and internal inputs (see [Table 6-16](#)) and outputs (see [Table 6-17](#))

Table 6-16. eCOMP0 Input Channel Connections

CPPSEL, CPNSEL	eCOMP0 CHANNELS	EXTERNAL OR INTERNAL CONNECTION
BINARY		
000	C0	P1.0
001	C1	P1.1
010	C2	P1.2
011	C3	P1.3
100	C4	Not used
101	C5	Not used
110	C6	Built-in 6-bit DAC

Table 6-17. eCOMP0 Output Channel Connections

eCOMP0 Out	EXTERNAL PIN OUT, MODULE
1	P2.0
2	TB0.1B ; TB0 (TB0OUTH); ADC

6.11.13 Embedded Emulation Module (EEM)

The EEM supports real-time in-system debugging. The EEM on these devices has the following features:

- Three hardware triggers or breakpoints on memory access
- One hardware trigger or breakpoint on CPU register write access
- Up to four hardware triggers that can be combined to form complex triggers or breakpoints
- One cycle counter
- Clock control on module level

6.11.14 Peripheral File Map

Table 6-18 lists the base address and the memory size of the registers for each peripheral.

Table 6-18. Peripherals Summary

MODULE NAME	BASE ADDRESS	SIZE
Special Functions (see Table 6-19)	0100h	0010h
PMM (see Table 6-20)	0120h	0020h
SYS (see Table 6-21)	0140h	0040h
CS (see Table 6-22)	0180h	0020h
FRAM (see Table 6-23)	01A0h	0010h
CRC (see Table 6-24)	01C0h	0008h
WDT (see Table 6-25)	01CCh	0002h
Port P1, P2 (see Table 6-26)	0200h	0020h
Capacitive Touch I/O (see Table 6-27)	02E0h	0010h
RTC (see Table 6-28)	0300h	0010h
Timer0_B3 (see Table 6-29)	0380h	0030h
eUSCI_A0 (see Table 6-30)	0500h	0020h
Backup Memory (see Table 6-31)	0660h	0020h
ADC ⁽¹⁾ (see Table 6-32)	0700h	0040h
eCOMP0 (see Table 6-33)	08E0h	0020h

(1) The ADC is not available on the MSP430FR2000 device.

Table 6-19. Special Function Registers (Base Address: 0100h)

REGISTER DESCRIPTION	REGISTER	OFFSET
SFR interrupt enable	SFRIE1	00h
SFR interrupt flag	SFRIFG1	02h
SFR reset pin control	SFRRPCR	04h

Table 6-20. PMM Registers (Base Address: 0120h)

REGISTER DESCRIPTION	REGISTER	OFFSET
PMM control 0	PMMCTL0	00h
PMM control 1	PMMCTL1	02h
PMM control 2	PMMCTL2	04h
PMM interrupt flags	PMMIFG	0Ah
PM5 control 0	PM5CTL0	10h

Table 6-21. SYS Registers (Base Address: 0140h)

REGISTER DESCRIPTION	REGISTER	OFFSET
System control	YSCTL	00h
Bootloader configuration area	YSBSLC	02h
JTAG mailbox control	YSJMBC	06h
JTAG mailbox input 0	YSJMBI0	08h
JTAG mailbox input 1	YSJMBI1	0Ah
JTAG mailbox output 0	YSJMBO0	0Ch
JTAG mailbox output 1	YSJMBO1	0Eh
User NMI vector generator	YSUNIV	1Ah
System NMI vector generator	YSSNIV	1Ch
Reset vector generator	YSRSTIV	1Eh
System configuration 0	YSFCG0	20h
System configuration 1	YSFCG1	22h
System configuration 2	YSFCG2	24h
System configuration 3	YSFCG3	26h

Table 6-22. CS Registers (Base Address: 0180h)

REGISTER DESCRIPTION	REGISTER	OFFSET
CS control 0	CSCTL0	00h
CS control 1	CSCTL1	02h
CS control 2	CSCTL2	04h
CS control 3	CSCTL3	06h
CS control 4	CSCTL4	08h
CS control 5	CSCTL5	0Ah
CS control 6	CSCTL6	0Ch
CS control 7	CSCTL7	0Eh
CS control 8	CSCTL8	10h

Table 6-23. FRAM Registers (Base Address: 01A0h)

REGISTER DESCRIPTION	REGISTER	OFFSET
FRAM control 0	FRCTL0	00h
General control 0	GCCTL0	04h
General control 1	GCCTL1	06h

Table 6-24. CRC Registers (Base Address: 01C0h)

REGISTER DESCRIPTION	REGISTER	OFFSET
CRC data input	CRC16DI	00h
CRC data input reverse byte	CRCDIRB	02h
CRC initialization and result	CRCINIRES	04h
CRC result reverse byte	CRCRESR	06h

Table 6-25. WDT Registers (Base Address: 01CCh)

REGISTER DESCRIPTION	REGISTER	OFFSET
Watchdog timer control	WDTCTL	00h

Table 6-26. Port P1, P2 Registers (Base Address: 0200h)

REGISTER DESCRIPTION	REGISTER	OFFSET
Port P1 input	P1IN	00h
Port P1 output	P1OUT	02h
Port P1 direction	P1DIR	04h
Port P1 pulling enable	P1REN	06h
Port P1 selection 0	P1SEL0	0Ah
Port P1 selection 1	P1SEL1	0Ch
Port P1 interrupt vector word	P1IV	0Eh
Port P1 interrupt edge select	P1IES	18h
Port P1 interrupt enable	P1IE	1Ah
Port P1 interrupt flag	P1IFG	1Ch
Port P2 input	P2IN	01h
Port P2 output	P2OUT	03h
Port P2 direction	P2DIR	05h
Port P2 pulling enable	P2REN	07h
Port P2 selection 0	P2SEL0	0Bh
Port P2 selection 1	P2SEL1	0Dh
Port P2 interrupt vector word	P2IV	1Eh
Port P2 interrupt edge select	P2IES	19h
Port P2 interrupt enable	P2IE	1Bh
Port P2 interrupt flag	P2IFG	1Dh

Table 6-27. Capacitive Touch I/O Registers (Base Address: 02E0h)

REGISTER DESCRIPTION	REGISTER	OFFSET
Capacitive Touch I/O 0 control	CAPIO0CTL	0Eh

Table 6-28. RTC Registers (Base Address: 0300h)

REGISTER DESCRIPTION	REGISTER	OFFSET
RTC control	RTCCTL	00h
RTC interrupt vector	RTCIV	04h
RTC modulo	RTCMOD	08h
RTC counter	RTCCNT	0Ch

Table 6-29. Timer0_B3 Registers (Base Address: 0380h)

REGISTER DESCRIPTION	REGISTER	OFFSET
TB0 control	TB0CTL	00h
Capture/compare control 0	TB0CCTL0	02h
Capture/compare control 1	TB0CCTL1	04h
Capture/compare control 2	TB0CCTL2	06h
TB0 counter	TB0R	10h
Capture/compare 0	TB0CCR0	12h
Capture/compare 1	TB0CCR1	14h
Capture/compare 2	TB0CCR2	16h
TB0 expansion 0	TB0EX0	20h
TB0 interrupt vector	TB0IV	2Eh

Table 6-30. eUSCI_A0 Registers (Base Address: 0500h)

REGISTER DESCRIPTION	REGISTER	OFFSET
eUSCI_A control word 0	UCA0CTLW0	00h
eUSCI_A control word 1	UCA0CTLW1	02h
eUSCI_A control rate 0	UCA0BR0	06h
eUSCI_A control rate 1	UCA0BR1	07h
eUSCI_A modulation control	UCA0MCTLW	08h
eUSCI_A status	UCA0STAT	0Ah
eUSCI_A receive buffer	UCA0RXBUF	0Ch
eUSCI_A transmit buffer	UCA0TXBUF	0Eh
eUSCI_A LIN control	UCA0ABCTL	10h
eUSCI_A IrDA transmit control	IUCA0IRTCTL	12h
eUSCI_A IrDA receive control	IUCA0IRRCTL	13h
eUSCI_A interrupt enable	UCA0IE	1Ah
eUSCI_A interrupt flags	UCA0IFG	1Ch
eUSCI_A interrupt vector word	UCA0IV	1Eh

Table 6-31. Backup Memory Registers (Base Address: 0660h)

REGISTER DESCRIPTION	REGISTER	OFFSET
Backup memory 0	BAKMEM0	00h
Backup memory 1	BAKMEM1	02h
Backup memory 2	BAKMEM2	04h
Backup memory 3	BAKMEM3	06h
Backup memory 4	BAKMEM4	08h
Backup memory 5	BAKMEM5	0Ah
Backup memory 6	BAKMEM6	0Ch
Backup memory 7	BAKMEM7	0Eh
Backup memory 8	BAKMEM8	10h
Backup memory 9	BAKMEM9	12h
Backup memory 10	BAKMEM10	14h
Backup memory 11	BAKMEM11	16h
Backup memory 12	BAKMEM12	18h
Backup memory 13	BAKMEM13	1Ah
Backup memory 14	BAKMEM14	1Ch
Backup memory 15	BAKMEM15	1Eh

Table 6-32. ADC Registers (Base Address: 0700h)

REGISTER DESCRIPTION	REGISTER	OFFSET
ADC control 0	ADCCTL0	00h
ADC control 1	ADCCTL1	02h
ADC control 2	ADCCTL2	04h
ADC window comparator low threshold	ADCLO	06h
ADC window comparator high threshold	ADCHI	08h
ADC memory control 0	ADCMCTL0	0Ah
ADC conversion memory	ADCMEM0	12h
ADC interrupt enable	ADCIE	1Ah
ADC interrupt flags	ADCIFG	1Ch
ADC interrupt vector word	ADCIV	1Eh

Table 6-33. eCOMP0 Registers (Base Address: 08E0h)

REGISTER DESCRIPTION	REGISTER	OFFSET
Comparator control 0	CPCTL0	00h
Comparator control 1	CPCTL1	02h
Comparator interrupt	CPINT	06h
Comparator interrupt vector	CPIV	08h
Comparator built-in DAC control	CPDACCTL	10h
Comparator built-in DAC data	CPDACDATA	12h

6.11.15 Input/Output Diagrams

6.11.15.1 Port P1 Input/Output With Schmitt Trigger

Figure 6-1 shows the port diagram. Table 6-34 summarizes the selection of the pin functions.

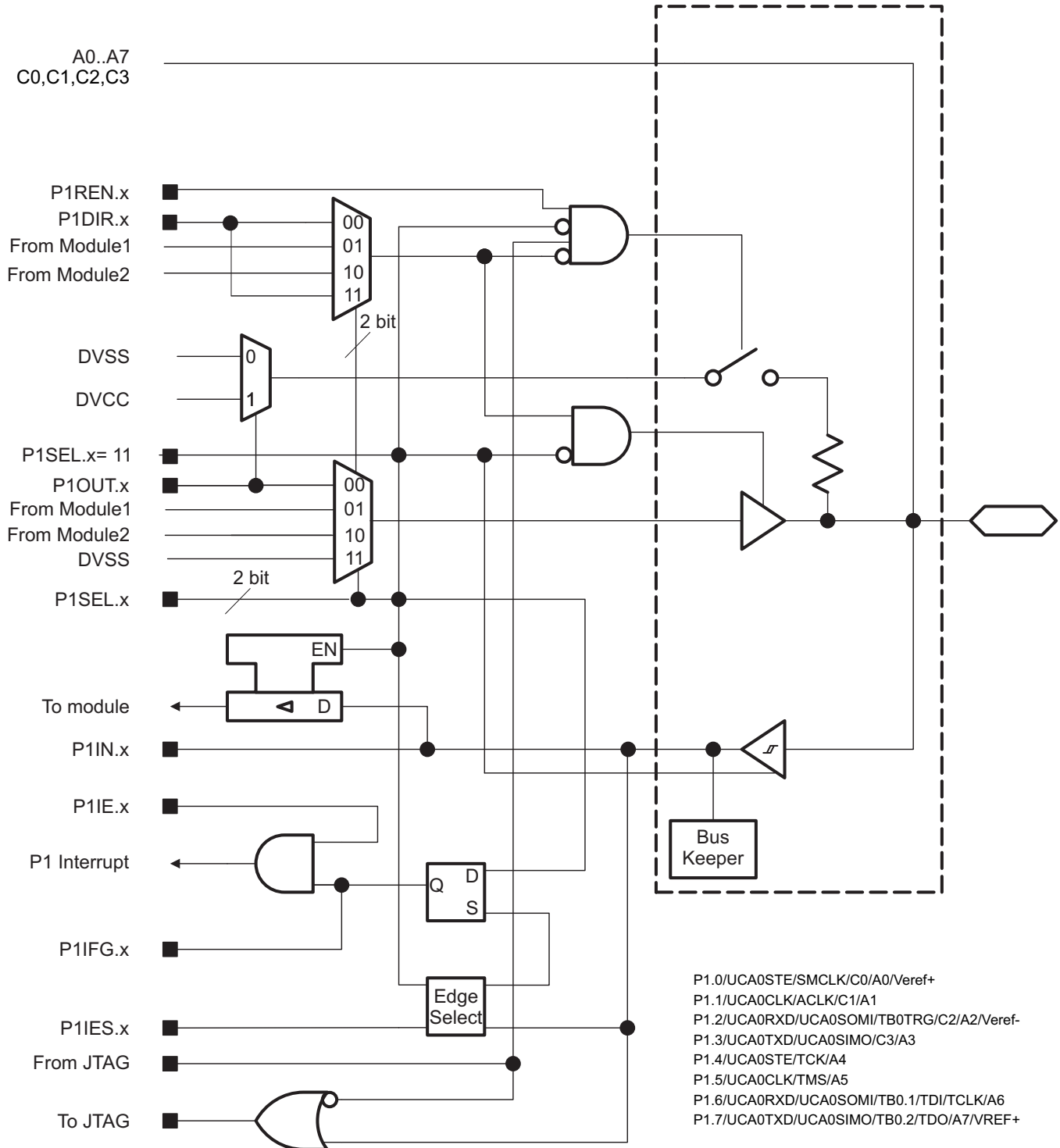

NOTE: Functional representation only.

NOTE: The ADC (signals A0 to A7, Verif+, and Verif-) is not available on the MSP430FR2000 device.

Figure 6-1. Port P1 Input/Output With Schmitt Trigger

Table 6-34. Port P1 Pin Functions

PIN NAME (P1.x)	x	FUNCTION	CONTROL BITS AND SIGNALS ⁽¹⁾		
			P1DIR.x	P1SELx	JTAG
P1.0/UCA0STE/SMCLK/ C0/A0/Veref+	0	P1.0 (I/O)	I: 0; O: 1	00	N/A
		UCA0STE	X	01	N/A
		SMCLK	1	10	N/A
		VSS	0		
		C0, A0/Veref+ ⁽²⁾	X	11	N/A
P1.1/UCA0CLK/ACLK/ C1/A1	1	P1.1 (I/O)	I: 0; O: 1	0	N/A
		UCA0CLK	X	01	N/A
		ACLK	1	10	N/A
		VSS	0		
		C1, A1 ⁽²⁾	X	11	N/A
P1.2/UCA0RXD/ UCA0SOMI/TB0TRG/ C2/A2/Veref-	2	P1.2 (I/O)	I: 0; O: 1	00	N/A
		UCA0RXD/UCA0SOMI	X	01	N/A
		TB0TRG	0	10	N/A
		C2, A2/Veref- ⁽²⁾	X	11	N/A
P1.3/UCA0TXD/ UCA0SIMO/C3/A3	3	P1.3 (I/O)	I: 0; O: 1	00	N/A
		UCA0TXD/UCA0SIMO	X	01	N/A
		C3, A3 ⁽²⁾	X	11	N/A
P1.4/UCA0STE/TCK/A4	4	P1.4 (I/O)	I: 0; O: 1	00	Disabled
		UCA0STE	X	01	N/A
		A4 ⁽²⁾	X	11	Disabled
		JTAG TCK	X	X	TCK
P1.5/UCA0CLK/TMS/A5	5	P1.5 (I/O)	I: 0; O: 1	00	Disabled
		UCA0CLK	X	01	N/A
		A5 ⁽²⁾	X	11	Disabled
		JTAG TMS	X	X	TMS
P1.6/UCA0RXD/ UCA0SOMI/TB0.1/ TDI/TCLK/A6	6	P1.6 (I/O)	I: 0; O: 1	00	Disabled
		UCA0RXD/UCA0SOMI	X	01	N/A
		TB0.CCI1A	0	10	N/A
		TB0.1	1		
		A6 ⁽²⁾	X	11	Disabled
		JTAG TDI/TCLK	X	X	TDI/TCLK
P1.7/UCA0TXD/ UCA0SIMO/TB0.2/ TDO/A7/VREF+	7	P1.7 (I/O)	I: 0; O: 1	00	Disabled
		UCA0TXD/UCA0SIMO	X	01	N/A
		TB0.CCI2A	0	10	N/A
		TB0.2	1		
		A7 ⁽²⁾ , VREF+	X	11	Disabled
		JTAG TDO	X	X	TDO

(1) X = don't care

(2) The ADC is not available on the MSP430FR2000 device.

6.11.15.2 Port P2 Input/Output With Schmitt Trigger

Figure 6-2 shows the port diagram. Table 6-35 summarizes the selection of the pin functions.

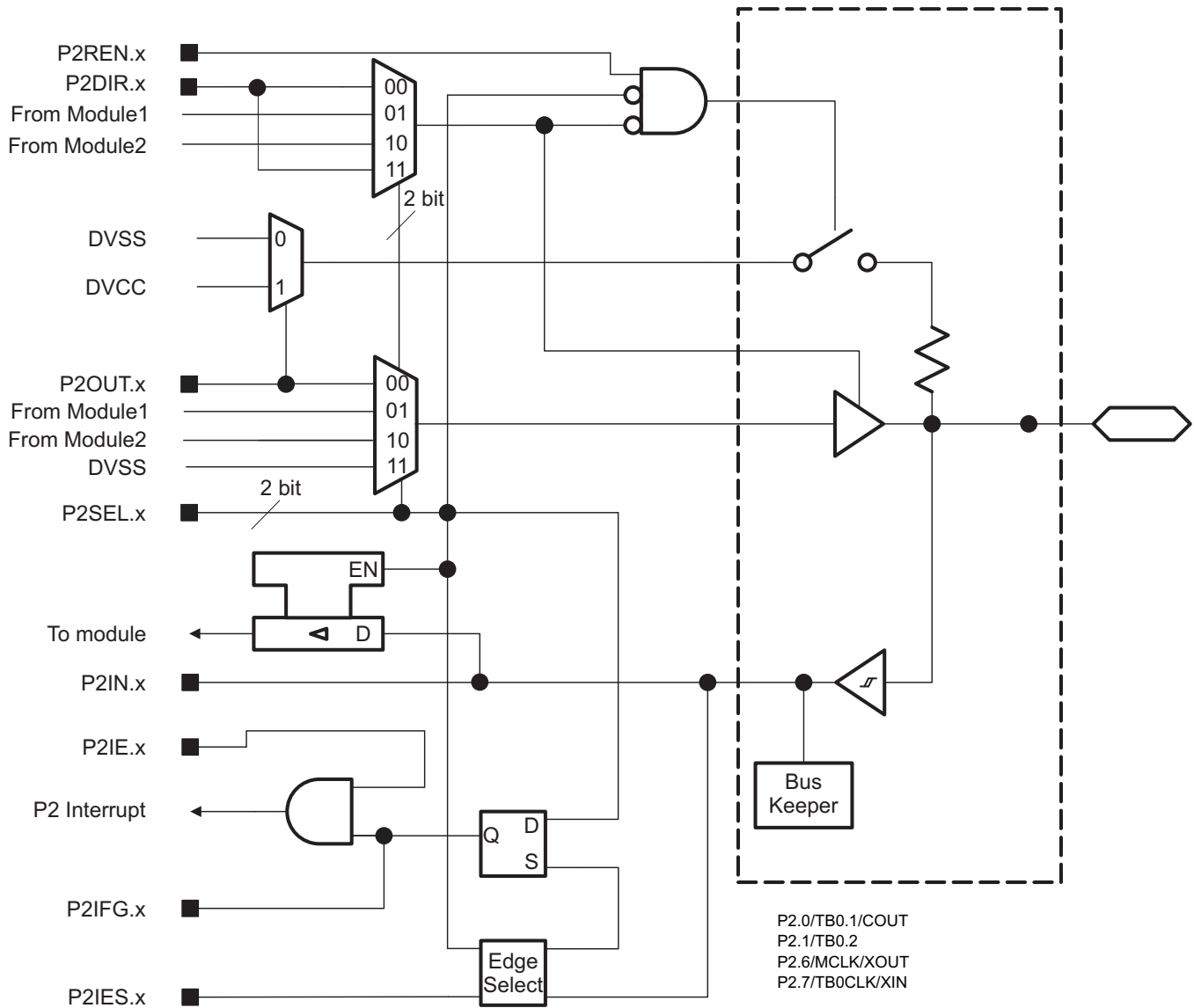

NOTE: Functional representation only.

Figure 6-2. Port P2 Input/Output With Schmitt Trigger

Table 6-35. Port P2 Pin Functions

PIN NAME (P2.x)	x	FUNCTION	CONTROL BITS AND SIGNALS ⁽¹⁾	
			P2DIR.x	P2SELx
P2.0/TB0.1/COU ^T	0	P2.0 (I/O)	I: 0; O: 1	00
		TB0.CCI1A	0	01
		TB0.1	1	
		COU ^T	1	10
P2.1/TB0.2	1	P2.1 (I/O)0	I: 0; O: 1	00
		TB0.CCI2A	0	01
		TB0.2	1	
P2.6/MCLK/XOU ^T	6	P2.6 (I/O)	I: 0; O: 1	00
		MCLK	1	01
		VSS	0	
		XOU ^T	X	10
P2.7/TB0CLK/XIN	7	P2.7 (I/O)	I: 0; O: 1	00
		TB0CLK	0	01
		VSS	1	
		XIN	X	10

(1) X = don't care

6.12 Device Descriptors (TLV)

Table 6-36 lists the Device IDs of the MSP430FR211x MCUs. Table 6-37 lists the contents of the device descriptor tag-length-value (TLV) structure for MSP430FR211x MCUs.

Table 6-36. Device IDs

DEVICE	DEVICE ID	
	1A04h	1A05h
MSP430FR2111	FA	82
MSP430FR2110	FB	82
MSP430FR2100	20	83
MSP430FR2000	21	83

Table 6-37. Device Descriptors

	DESCRIPTION	MSP430FR211x	
		ADDRESS	VALUE
Info Block	Info length	1A00h	06h
	CRC length	1A01h	06h
	CRC value ⁽¹⁾	1A02h	Per unit
		1A03h	Per unit
	Device ID	1A04h	See Table 6-36
		1A05h	
	Hardware revision	1A06h	Per unit
Firmware revision	1A07h	Per unit	
Die Record	Die record tag	1A08h	08h
	Die record length	1A09h	0Ah
	Lot wafer ID	1A0Ah	Per unit
		1A0Bh	Per unit
		1A0Ch	Per unit
		1A0Dh	Per unit
	Die X position	1A0Eh	Per unit
		1A0Fh	Per unit
	Die Y position	1A10h	Per unit
		1A11h	Per unit
Test result	1A12h	Per unit	
	1A13h	Per unit	
ADC Calibration ⁽²⁾	ADC calibration tag	1A14h	Per unit
	ADC calibration length	1A15h	Per unit
	ADC gain factor	1A16h	Per unit
		1A17h	Per unit
	ADC offset	1A18h	Per unit
		1A19h	Per unit
	ADC 1.5-V reference temperature 30°C	1A1Ah	Per unit
		1A1Bh	Per unit
	ADC 1.5-V reference temperature 85°C	1A1Ch	Per unit
1A1Dh		Per unit	

(1) The CRC value includes the checksum from 0x1A04h to 0x1A77h, calculated by applying the CRC-CCITT-16 polynomial of $X^{16} + X^{12} + X^5 + 1$

(2) The ADC is not available on the MSP430FR2000 device.

Table 6-37. Device Descriptors (continued)

	DESCRIPTION	MSP430FR211x	
		ADDRESS	VALUE
Reference and DCO Calibration	Calibration tag	1A1Eh	12h
	Calibration length	1A1Fh	04h
	1.5-V reference factor	1A20h	Per unit
		1A21h	Per unit
	DCO tap settings for 16 MHz, temperature 30°C ⁽³⁾	1A22h	Per unit
		1A23h	Per unit

(3) This value can be directly loaded into the DCO bits in the CSCTL0 register to get accurate 16-MHz frequency at room temperature, especially when the MCU exits from LPM3 and below. TI suggests using a predivider to decrease the frequency if the temperature drift might result an overshoot >16 MHz.

6.13 Identification

6.13.1 Revision Identification

The device revision information is shown as part of the top-side marking on the device package. The device-specific errata sheet describes these markings. For links to the errata sheets for the devices in this data sheet, see [§ 8.4](#).

The hardware revision is also stored in the Device Descriptor structure in the Info Block section. For details on this value, see the "Hardware Revision" entries in [Section 6.12](#).

6.13.2 Device Identification

The device type can be identified from the top-side marking on the device package. The device-specific errata sheet describes these markings. For links to the errata sheets for the devices in this data sheet, see [§ 8.4](#).

A device identification value is also stored in the Device Descriptor structure in the Info Block section. For details on this value, see the "Device ID" entries in [Section 6.12](#).

6.13.3 JTAG Identification

Programming through the JTAG interface, including reading and identifying the JTAG ID, is described in detail in [MSP430 Programming With the JTAG Interface](#).

7 Applications, Implementation, and Layout

NOTE

Information in the following applications sections is not part of the TI component specification, and TI does not warrant its accuracy or completeness. TI's customers are responsible for determining suitability for components for their purposes. Customers should validate and test their implementation to confirm system functionality.

7.1 Device Connection and Layout Fundamentals

This section describes the recommended guidelines when designing with the MSP430 MCU. These guidelines are to make sure that the device has proper connections for powering, programming, debugging, and optimum analog performance.

7.1.1 Power Supply Decoupling and Bulk Capacitors

TI recommends connecting a combination of a 10- μ F capacitor and a 100-nF low-ESR ceramic decoupling capacitor to the DVCC pin. Higher-value capacitors may be used but can affect supply rail ramp-up time. Place decoupling capacitors as close as possible to the pins that they decouple (within a few millimeters).

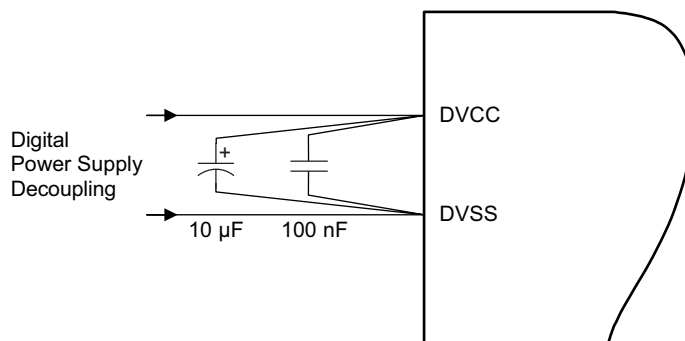

Figure 7-1. Power Supply Decoupling

7.1.2 External Oscillator

Depending on the device variant (see [Table 3-1](#)), the device supports only a low-frequency crystal (32 kHz) on the LFXT pins. External bypass capacitors for the crystal oscillator pins are required.

It is also possible to apply digital clock signals to the LFXIN input pins that meet the specifications of the respective oscillator if the appropriate LFXTBYPASS mode is selected. In this case, the associated LFXOUT pins can be used for other purposes. If the LFXOUT pins are left unused, they must be terminated according to [Section 4.5](#).

[Figure 7-2](#) shows a typical connection diagram. See [MSP430 32-kHz Crystal Oscillators](#) for information on selecting, testing, and designing a crystal oscillator with the MSP430 devices.

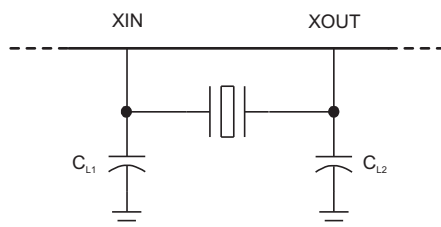

Figure 7-2. Typical Crystal Connection

7.1.3 JTAG

With the proper connections, the debugger and a hardware JTAG interface (such as the MSP-FET or MSP-FET430UIF) can be used to program and debug code on the target board. In addition, the connections also support the MSP-GANG production programmers, thus providing an easy way to program prototype boards, if desired. Figure 7-3 shows the connections between the 14-pin JTAG connector and the target device required to support in-system programming and debugging for 4-wire JTAG communication. Figure 7-4 shows the connections for 2-wire JTAG mode (Spy-Bi-Wire).

The connections for the MSP-FET and MSP-FET430UIF interface modules and the MSP-GANG are identical. Both can supply V_{CC} to the target board (through pin 2). In addition, the MSP-FET and MSP-FET430UIF interface modules and MSP-GANG have a V_{CC} -sense feature that, if used, requires an alternate connection (pin 4 instead of pin 2). The V_{CC} -sense feature senses the local V_{CC} present on the target board (that is, a battery or other local power supply) and adjusts the output signals accordingly. Figure 7-3 and Figure 7-4 show a jumper block that supports both scenarios of supplying V_{CC} to the target board. If this flexibility is not required, the desired V_{CC} connections may be hardwired to eliminate the jumper block. Pins 2 and 4 must not be connected at the same time.

For additional design information regarding the JTAG interface, see the [MSP430 Hardware Tools User's Guide](#).

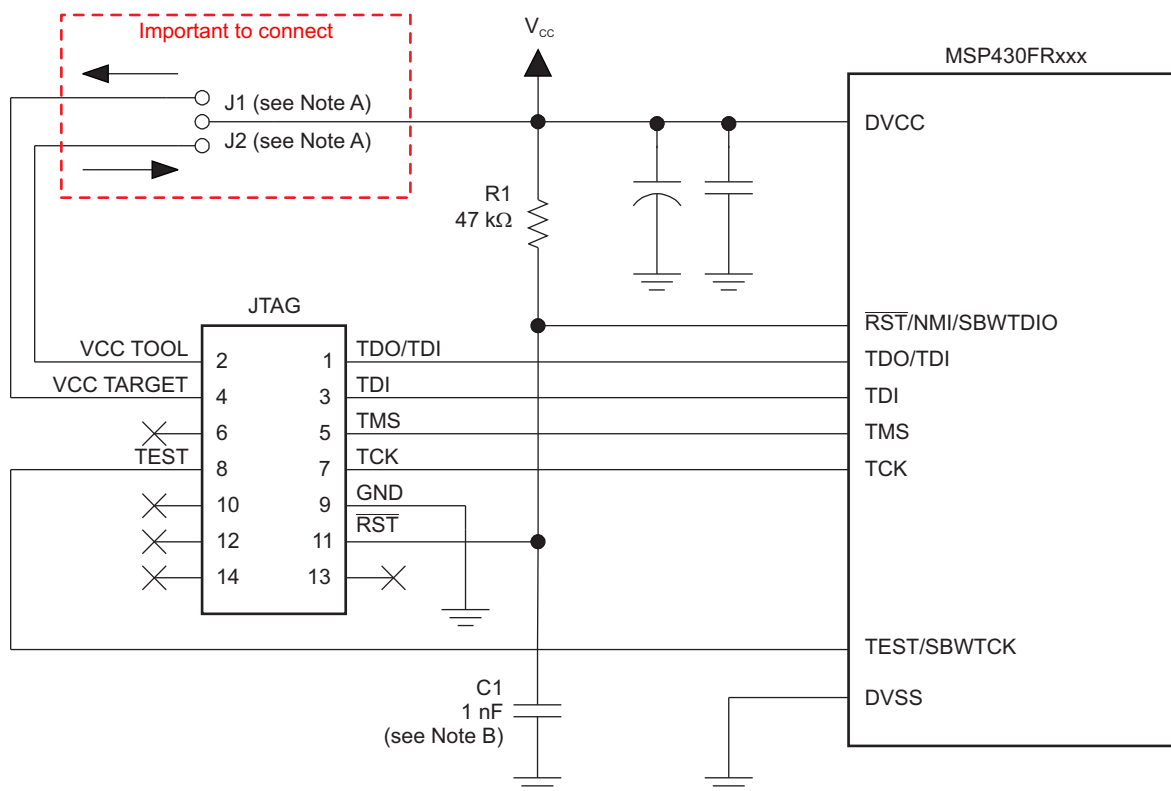

Copyright © 2016, Texas Instruments Incorporated

- If a local target power supply is used, make connection J1. If power from the debug or programming adapter is used, make connection J2.
- The upper limit for C1 is 1.1 nF when using current TI tools.

Figure 7-3. Signal Connections for 4-Wire JTAG Communication

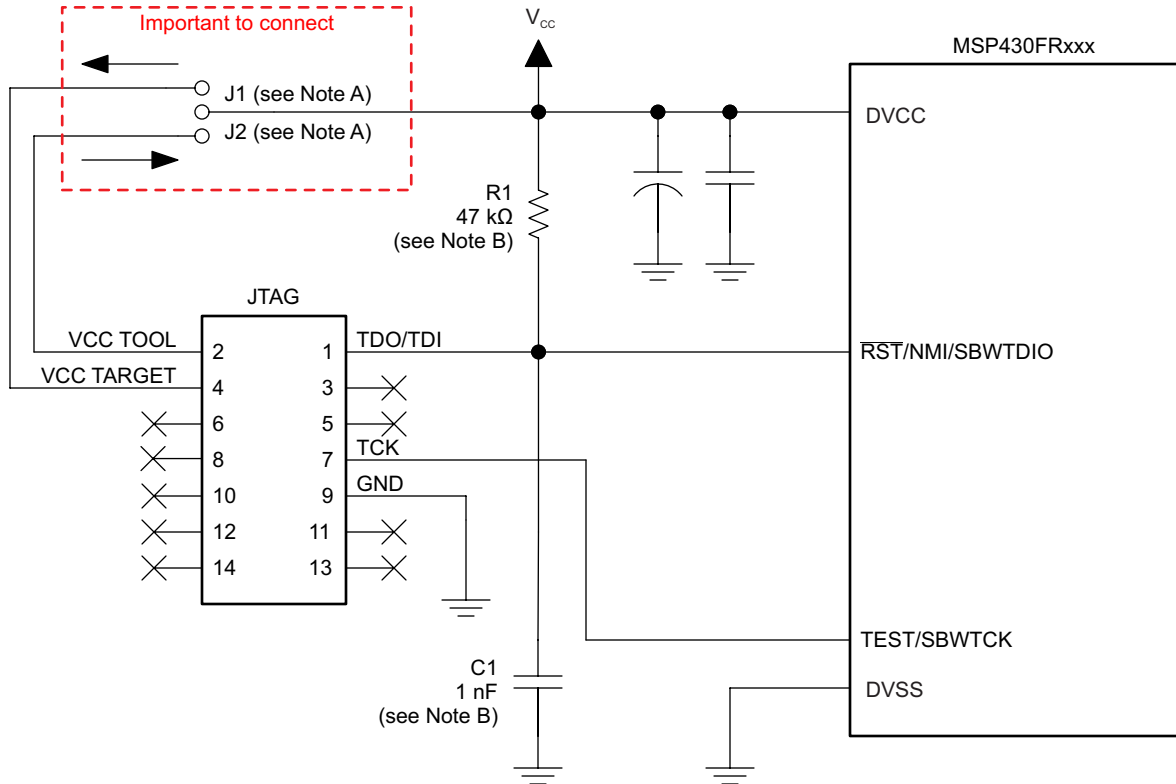

Copyright © 2016, Texas Instruments Incorporated

- Make connection J1 if a local target power supply is used, or make connection J2 if the target is powered from the debug or programming adapter.
- The device $\overline{\text{RST/NMI/SBWTIO}}$ pin is used in 2-wire mode for bidirectional communication with the device during JTAG access, and any capacitance that is attached to this signal may affect the ability to establish a connection with the device. The upper limit for C1 is 1.1 nF when using current TI tools.

Figure 7-4. Signal Connections for 2-Wire JTAG Communication (Spy-Bi-Wire)

7.1.4 Reset

The reset pin can be configured as a reset function (default) or as an NMI function in the Special Function Register (SFR), SFRRPCR.

In reset mode, the $\overline{\text{RST/NMI}}$ pin is active low, and a pulse applied to this pin that meets the reset timing specifications generates a BOR-type device reset.

Setting SYSNMI causes the $\overline{\text{RST/NMI}}$ pin to be configured as an external NMI source. The external NMI is edge sensitive, and its edge is selectable by SYSNMIIES. Setting the NMIIE enables the interrupt of the external NMI. When an external NMI event occurs, the NMIIFG is set.

The $\overline{\text{RST/NMI}}$ pin can have either a pullup or pulldown that is enabled or not. SYSRSTUP selects either pullup or pulldown, and SYSRSTRE causes the pullup (default) or pulldown to be enabled (default) or not. If the $\overline{\text{RST/NMI}}$ pin is unused, it is required either to select and enable the internal pullup or to connect an external 47-kΩ pullup resistor to the $\overline{\text{RST/NMI}}$ pin with a 10-nF pulldown capacitor. The pulldown capacitor should not exceed 1.1 nF when using devices with Spy-Bi-Wire interface in Spy-Bi-Wire mode or in 4-wire JTAG mode with TI tools like FET interfaces or GANG programmers.

See the [MSP430FR4xx and MSP430FR2xx Family User's Guide](#) for more information on the referenced control registers and bits.

7.1.5 Unused Pins

For details on the connection of unused pins, see [Section 4.5](#).

7.1.6 General Layout Recommendations

- Proper grounding and short traces for external crystal to reduce parasitic capacitance. See [MSP430 32-kHz Crystal Oscillators](#) for recommended layout guidelines.
- Proper bypass capacitors on DVCC, AVCC, and reference pins if used.
- Avoid routing any high-frequency signal close to an analog signal line. For example, keep digital switching signals such as PWM or JTAG signals away from the oscillator circuit and ADC signals.
- Proper ESD level protection should be considered to protect the device from unintended high-voltage electrostatic discharge. See [MSP430 System-Level ESD Considerations](#) for guidelines.

7.1.7 Do's and Don'ts

During power up, power down, and device operation, the voltage difference between AVCC and DVCC must not exceed the limits specified in [Absolute Maximum Ratings](#). Exceeding the specified limits may cause malfunction of the device including erroneous writes to RAM and FRAM.

7.2 Peripheral- and Interface-Specific Design Information

7.2.1 ADC Peripheral

NOTE

The ADC is not available on the MSP430FR2000 device.

7.2.1.1 Partial Schematic

Figure 7-5 shows the recommended decoupling circuit with either an internal or an external voltage reference.

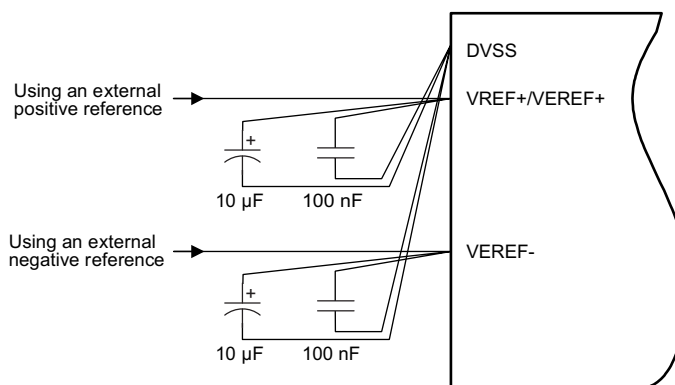

Figure 7-5. ADC Grounding and Noise Considerations

7.2.1.2 Design Requirements

As with any high-resolution ADC, appropriate printed-circuit-board layout and grounding techniques should be followed to eliminate ground loops, unwanted parasitic effects, and noise.

Ground loops are formed when return current from the ADC flows through paths that are common with other analog or digital circuitry. If care is not taken, this current can generate small unwanted offset voltages that can add to or subtract from the reference or input voltages of the ADC. The general guidelines in [Section 7.1.1](#) combined with the connections shown in [Section 7.2.1.1](#) prevent this.

In addition to grounding, ripple and noise spikes on the power-supply lines that are caused by digital switching or switching power supplies can corrupt the conversion result. TI recommends a noise-free design using separate analog and digital ground planes with a single-point connection to achieve high accuracy.

Figure 7-5 shows the recommended decoupling circuit when an external voltage reference is used. The internal reference module has a maximum drive current as described in the sections *ADC Pin Enable* and *1.2-V Reference Settings* of the *MSP430FR4xx and MSP430FR2xx Family User's Guide*.

The reference voltage must be a stable voltage for accurate measurements. The capacitor values that are selected in the general guidelines filter out the high- and low-frequency ripple before the reference voltage enters the device. In this case, the 10- μ F capacitor is used to buffer the reference pin and filter any low-frequency ripple. A bypass capacitor of 100 nF is used to filter out any high-frequency noise.

7.2.1.3 Layout Guidelines

Components that are shown in the partial schematic (see Figure 7-5) should be placed as close as possible to the respective device pins to avoid long traces, because they add additional parasitic capacitance, inductance, and resistance on the signal.

Avoid routing analog input signals close to a high-frequency pin (for example, a high-frequency PWM), because the high-frequency switching can be coupled into the analog signal.

7.3 Typical Applications

Table 7-1 lists several TI Designs that reflect the use of the MSP430FR211x family of devices in different real-world application scenarios. Consult these designs for additional guidance regarding schematic, layout, and software implementation. For the most up-to-date list of available TI Designs, see the device-specific product folders listed in 节 8.5.

Table 7-1. TI Designs

DESIGN NAME	LINK
Thermostat Implementation With MSP430FR4xx	TIDM-FRAM-THERMOSTAT
Water Meter Implementation With MSP430FR4xx	TIDM-FRAM-WATERMETER
Remote Controller of Air Conditioner Using Low-Power Microcontroller	TIDM-REMOTE-CONTROLLER-FOR-AC

8 器件和文档支持

8.1 入门和后续步骤

要获得有助于您开发工作的 MSP430™ 系列器件、工具和库的更多相关信息，请访问 [入门](#) 页面。

8.2 器件命名规则

为了标示产品开发周期所处的阶段，TI 为所有 MSP MCU 器件的部件号分配了前缀。每个 MSP MCU 商用系列产品成员都具有以下两个前缀之一：MSP 或 XMS。这些前缀代表了产品开发的发展阶段，即从工程原型 (XMS) 直到完全合格的生产器件 (MSP)。

XMS - 实验器件，不一定代表最终器件的电气规格

MSP - 完全合格的生产器件

XMS 器件在供货时附带如下免责声明：

“开发中的产品用于内部评估用途。”

MSP 器件的特性已经全部明确，并且器件的质量和可靠性已经完全论证。TI 的标准保修证书对该器件适用。

预测显示原型器件 (XMS) 的故障率大于标准生产器件。由于这些器件的预计最终使用故障率尚不确定，德州仪器 (TI) 建议不要将它们用于任何生产系统。请仅使用合格的生产器件。

TI 器件的命名规则还包括一个带有器件系列名称的后缀。此后缀表示温度范围、封装类型和配送形式。图 8-1 提供了解读完整器件名称的图例。



图 8-1. 器件命名规则

8.3 工具与软件

所有 MSP 微控制器均受多种软件和硬件开发工具的支持。相关工具由 TI 以及多家第三方供应商提供。可从 [低功耗 MCU 开发套件和软件](#) 获取全部信息。

表 8-1 列出了 MSP430FR235x 和 MSP430FR215x 微控制器所支持的调试功能。关于可用特性的详细信息，请参见《[适用于 MSP430 的 Code Composer Studio 用户指南](#)》。

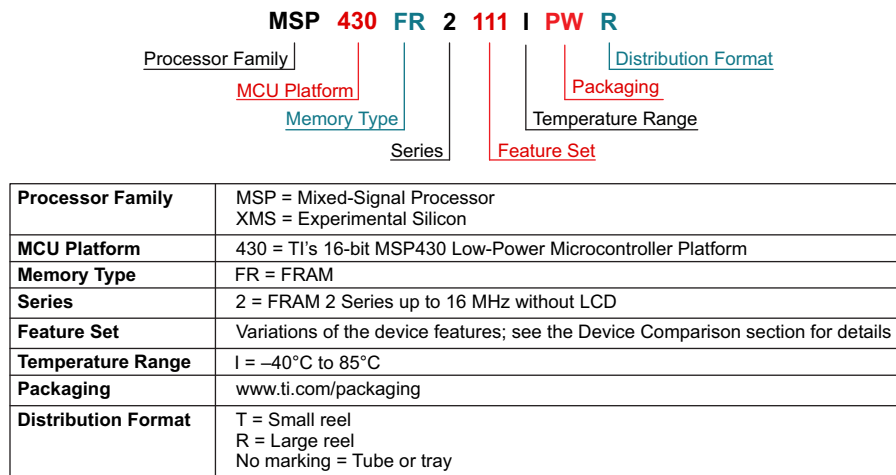
表 8-1. 硬件调试 特性

MSP430 架构	四线制 JTAG	2 线 JTAG	断点 (N)	范围断点	时钟控制	状态序列发生器	跟踪缓冲器	LPMx.5 调试支持	EEM 版本
MSP430Xv2	有	有	3	有	是	否	否	否	S

设计套件与评估模块

中的“设计套件和评估模块”说明

适用于 MSP430FR23x/21x MCU 的 20 引脚目标插座开发板 MSP-TS430PW20 是一款独立的 ZIF 插座目标板，用于通过 JTAG 接口或 Spy Bi-Wire（双线制 JTAG）协议对 MSP430 MCU 系统进行编程和调试。该开发板支持采用 20 引脚或 16 引脚的 TSSOP 封装（TI 封装代码：PW）的所有 MSP430FR2000、MSP430FR21x 和 MSP430FR23x FRAM MCU。

MSP430FR2311 LaunchPad 开发套件 MSP-EXP430FR2311 LaunchPad 开发套件是一款适用于 MSP430FR2000、MSP430FR21x 和 MSP430FR23x MCU 系列的微控制器开发板。此套件包含对平台进行评估所需要的所有资源，包括用于编程、调试和能量测量的板载仿真。板载按钮和 LED 允许集成简单的用户交互。

MSP430FR4133 LaunchPad 开发套件 MSP-EXP430FR4133 LaunchPad 开发套件是一款适用于 MSP430FR2xx 和 MSP430FR4xx MCU 系列的微控制器开发板。此套件包含对 MSP430FR2xx 和 MSP430FR4xx FRAM 平台进行评估所需要的所有资源，包括用于编程、调试和能量测量的板载仿真。板载按钮和 LED 允许集成简单的用户交互，而且 BoosterPack™ 插件模块的 20 引脚接头允许使用 BoosterPack 模块进行快速的用户实验。

MSP-FET + MSP-TS430PW20 FRAM 微控制器开发套件包 MSP-FET430U20 开发套件包将两种调试工具相结合，支持 MSP430FR2000、MSP430FR21xx 和 MSP430FR23xx MCU 的 20 引脚 PW 封装（例如 MSP430FR2311IPW20）。所包括的工具是 MSP-TS430PW20 和 MSP-FET。

软件

MSP430Ware™ 软件 MSP430Ware 软件集合了所有 MSP430 器件的代码示例、产品说明书以及其他设计资源，打包提供给用户。除了提供已有 MSP430 设计资源的完整集合外，MSP430Ware 软件还包含名为 MSP 驱动程序库的高级 API。借助该库可以轻松地对 MSP430 硬件进行编程。MSP430Ware 软件以 CCS 组件或独立软件包两种形式提供。

MSP430FR21xx 代码示例 根据不同应用需求配置各集成外设的每个 MSP 器件均具备相应的 C 代码示例。

MSP 驱动程序库 MSP 驱动程序库的抽象 API 提供易用的函数调用，无需直接操纵 MSP430 硬件的位与字节。完整的文档通过具有帮助意义的 API 指南交付，其中包括有关每个函数调用和经过验证的参数的详细信息。开发人员可使用驱动程序库函数以尽可能低的费用编写全部项目。

ULP（超低功耗）Advisor ULP Advisor™ 软件是一款辅助工具，旨在指导开发人员编写更为高效的代码，从而充分利用 MSP430 和 MSP432 微控制器独特功能。ULP Advisor 的目标人群是微控制器的资深开发者和开发新手，可以根据详尽的 ULP 检验表检查代码，以便最大限度地减少应用程序的能耗。在编译时，ULP Advisor 会提供通知和备注以突出显示代码中可以进一步优化的区域，进而实现更低功耗。

IEC60730 软件包 IEC60730 MSP430 软件包经过专门开发，用于协助客户达到 IEC 60730-1:2010（家用及类似用途的自动化电气控制 - 第 1 部分：一般要求）B 类产品的要求。其中涵盖家用电器、电弧检测器、电源转换器、电动工具、电动自行车及其他诸多产品。IEC60730 MSP430 软件包可以嵌入在 MSP430 MCU 中运行的客户应用，从而帮助客户简化其消费类器件在功能安全方面遵循 IEC 60730-1:2010 B 类规范的认证工作。

适用于 MSP 的定点数学库 MSP IQmath 和 Qmath 库是为 C 语言开发者提供的一套经过高度优化的高精度数学运算函数集合，能够将浮点算法无缝嵌入 MSP430 和 MSP432 器件的定点代码中。这些例程通常用于计算密集型实时应用，而优化的执行速度、高精度以及超低能耗通常是影响这些实时应用的关键因素。与使用浮点数学算法编写的同等代码相比，使用 IQmath 和 Qmath 库可以大幅提高执行速度并显著降低能耗。

适用于 MSP430 的浮点数学运算库 TI 在低功耗和低成本微控制器领域锐意创新，为您提供 MSPMATHLIB。此标量函数的浮点数学运算库，能够充分利用器件的智能外设，使速度最高达到标准 MSP430 数学函数的 26 倍。Mathlib 能够轻松集成到您的设计中。该运算库免费使用并集成在 Code Composer Studio IDE 和 IAR Embedded Workbench IDE 中。

开发工具

适用于 MSP 微控制器的 Code Composer Studio™ 集成开发环境 Code Composer Studio (CCS) 集成开发环境 (IDE) 支持所有 MSP 微控制器器件。CCS 包含一整套用于开发和调试嵌入式应用的工具。它包含了优化的 C/C++ 编译器、源代码编辑器、项目构建环境、调试器、描述器以及其他多种功能。

MSP EnergyTrace™ 技术 适用于 MSP430 微控制器的 EnergyTrace 技术是基于电能的代码分析工具，适用于测量和显示应用的电能系统配置并帮助优化应用以实现超低功耗。

命令行编程器 MSP Flasher 是一款基于 shell 的开源接口，可使用 JTAG 或 Spy-Bi-Wire (SBW) 通信通过 FET 编程器或 eZ430 对 MSP 微控制器进行编程。MSP Flasher 可用于将二进制文件 (.txt 或 .hex 文件) 直接下载到 MSP 微控制器，而无需使用 IDE。

MSP MCU 编程器和调试器 MSP-FET 是一款强大的仿真开发工具（通常称为调试探针），可帮助用户在 MSP 低功耗微控制器 (MCU) 中快速开发应用。创建 MCU 软件通常需要将生成的二进制程序下载到 MSP 器件中，从而进行验证和调试。

MSP-GANG 生产编程器 MSP Gang 编程器是一款 MSP430 或 MSP432 器件编程器，可同时对多达八个完全相同的 MSP430 或 MSP432 闪存或 FRAM 器件进行编程。MSP Gang 编程器可使用标准的 RS-232 或 USB 连接与主机 PC 相连并提供灵活的编程选项，允许用户完全自定义流程。

8.4 文档支持

以下文档介绍了 MSP430FR211x 微控制器。www.ti.com.cn 网站上提供了这些文档的副本。

接收文档更新通知

要接收文档更新通知（包括芯片勘误表），请转至 ti.com.cn 上您的器件对应的产品文件夹（请参见节 8.5 获取产品文件夹链接）。请单击右上角的“通知我”按钮。点击注册后，即可收到产品信息更改每周摘要（如有）。有关更改的详细信息，请查阅已修订文档的修订历史记录。

勘误

- 《[MSP430FR2111 器件勘误表](#)》 描述了针对这款器件的所有芯片修订版本功能技术规格的已知例外情况。
- 《[MSP430FR2110 器件勘误表](#)》 描述了针对这款器件的所有芯片修订版本功能技术规格的已知例外情况。
- 《[MSP430FR2100 器件勘误表](#)》 描述了针对这款器件的所有芯片修订版本功能技术规格的已知例外情况。
- 《[MSP430FR2000 器件勘误表](#)》 介绍了这款器件所有芯片修订版本的功能技术规格的已知例外情况。

用户指南

- 《[MSP430FR4xx 和 MSP430FR2xx 系列用户指南](#)》 详细介绍了该器件系列提供的模块和外设。
- 《[MSP430 FRAM 器件引导加载程序 \(BSL\) 用户指南](#)》 MSP430 MCU 上的引导加载程序 (BSL) 允许用户在原型设计、投产和维护等各阶段与 MSP430 MCU 中的嵌入式存储器进行通信。可编程存储器 (FRAM) 和数据存储器 (RAM) 均可根据需要进行修改。
- 《[通过 JTAG 接口对 MSP430 进行编程](#)》 此文档介绍了使用 JTAG 通信端口擦除、编程和验证基于 MSP430 闪存和 FRAM 的微控制器系列的存储器模块所需的功能。此外，该文档还介绍了如何编程所有 MSP430 器件上均具备的 JTAG 访问安全保险丝。此文档介绍了使用标准四线制 JTAG 接口和两线制 JTAG 接口（也称为 Spy-Bi-Wire (SBW)）的器件访问。
- 《[MSP430 硬件工具用户指南](#)》 此手册介绍了 TI MSP-FET430 闪存仿真工具 (FET) 的硬件。FET 是针对 MSP430 超低功耗微控制器的程序开发工具。

应用报告

- 《[MSP430 FRAM 技术 – 操作方法和最佳实践](#)》 FRAM 采用非易失性存储器技术，行为与 SRAM 类似，支持大量新应用的同时，还改变了固件的设计方式。该应用程序报告从嵌入式软件开发方面概述了 FRAM 技术在 MSP430 中的使用方法和最佳实践。其中介绍了如何按照应用程序特定的代码、常量、数据空间要求实施存储器布局以及如何使用 FRAM 优化应用程序的能耗。
- 《[MSP430FR4xx 和 MSP430FR2xx 系列的 VLO 校准](#)》 MSP430FR4xx 和 MSP430FR2xx (FR4xx/FR2xx) 系列微控制器 (MCU) 提供了各种时钟源，包括一些高速、高精度时钟以及一些低功耗、低系统成本时钟。用户可以选择以最佳方式权衡了性能、功耗和系统成本的时钟。片上超低频振荡器 (VLO) 是 FR4xx/FR2xx 系列 MCU 中包含的频率为 10kHz（典型值）的时钟源。VLO 具有超低的功耗，因而广泛适用于各种应用。

《**MSP430 32kHz 晶体振荡器**》 选择合适的晶体、正确的负载电路和适当的电路板布局是实现稳定的晶体振荡器的关键。该应用报告总结了晶体振荡器的功能，介绍了用于选择合适的晶体以实现 MSP430 超低功耗运行的参数。此外，还给出了正确电路板布局的提示和示例。此外，为了确保振荡器在大规模生产后能够稳定运行，还可能需要进行一些振荡器测试，该文档中提供了有关这些测试的详细信息。

《**MSP430 系统级 ESD 注意事项**》 随着硅晶技术向更低电压方向发展以及设计具有成本效益的超低功耗组件的需求的出现，系统级 ESD 要求变得越来越苛刻。该应用报告介绍了三个不同的 ESD 主题，旨在帮助电路板设计人员和 OEM 理解并设计出稳健耐用的系统级设计。

8.5 相关链接

表 8-2 列出了快速访问链接。类别包括技术文档、支持与社区资源、工具和软件，以及申请样片或购买产品的快速链接。

表 8-2. 相关链接

器件	产品文件夹	立即订购	技术文档	工具与软件	支持和社区
MSP430FR2111	请单击此处	请单击此处	请单击此处	请单击此处	请单击此处
MSP430FR2110	请单击此处	请单击此处	请单击此处	请单击此处	请单击此处
MSP430FR2100	请单击此处	请单击此处	请单击此处	请单击此处	请单击此处
MSP430FR2000	请单击此处	请单击此处	请单击此处	请单击此处	请单击此处

8.6 社区资源

下列链接提供到 TI 社区资源的连接。链接的内容由各个分销商“按照原样”提供。这些内容并不构成 TI 技术规范，并且不一定反映 TI 的观点；请参见 TI 的《使用条款》。

TI E2E™ 社区

TI 的工程师交流 (E2E) 社区。此社区的创建目的是为了促进工程师之间协作。在 e2e.ti.com 中，您可以提问、共享知识、拓展思路，在同领域工程师的帮助下解决问题。

TI 嵌入式处理器维基网页

德州仪器 (TI) 嵌入式处理器维基网页。此网站的建立是为了帮助开发人员熟悉德州仪器 (TI) 的嵌入式处理器，并且也为了促进与这些器件相关的硬件和软件的总体知识的创新和增长。

8.7 商标

MSP430, LaunchPad, MSP430Ware, Code Composer Studio, E2E, 《MSP430, BoosterPack, ULP Advisor, 适用于 MSP 微控制器的 Code Composer Studio, EnergyTrace are trademarks of Texas Instruments.

8.8 静电放电警告



ESD 可能会损坏该集成电路。德州仪器 (TI) 建议通过适当的预防措施处理所有集成电路。如果不遵守正确的处理措施和安装程序，可能会损坏集成电路。

ESD 的损坏小至导致微小的性能降级，大至整个器件故障。精密的集成电路可能更容易受到损坏，这是因为非常细微的参数更改都可能会导致器件与其发布的规格不相符。

8.9 术语表

TI 术语表 这份术语表列出并解释术语、缩写和定义。

9 机械、封装和可订购信息

以下页面包含机械、封装和可订购信息。这些信息是指定器件的最新可用数据。数据如有变更，恕不另行通知，且不会对此文档进行修订。如需获取此产品说明书的浏览器版本，请查阅左侧的导航栏。

重要声明和免责声明

TI 均以“原样”提供技术性及其可靠性数据（包括数据表）、设计资源（包括参考设计）、应用或其他设计建议、网络工具、安全信息和其他资源，不保证其中不含任何瑕疵，且不做任何明示或暗示的担保，包括但不限于对适销性、适合某特定用途或不侵犯任何第三方知识产权的暗示担保。

所述资源可供专业开发人员应用TI 产品进行设计使用。您将对以下行为独自承担全部责任：(1) 针对您的应用选择合适的TI 产品；(2) 设计、验证并测试您的应用；(3) 确保您的应用满足相应标准以及任何其他安全、安保或其他要求。所述资源如有变更，恕不另行通知。TI 对您使用所述资源的授权仅限于开发资源所涉及TI 产品的相关应用。除此之外不得复制或展示所述资源，也不提供其它TI 或任何第三方的知识产权授权许可。如因使用所述资源而产生任何索赔、赔偿、成本、损失及债务等，TI 对此概不负责，并且您须赔偿由此对TI 及其代表造成的损害。

TI 所提供产品均受TI 的销售条款 (<http://www.ti.com.cn/zh-cn/legal/termsofsale.html>) 以及ti.com.cn上或随附TI产品提供的其他可适用条款的约束。TI提供所述资源并不扩展或以其他方式更改TI 针对TI 产品所发布的可适用的担保范围或担保免责声明。

邮寄地址：上海市浦东新区世纪大道 1568 号中建大厦 32 楼，邮政编码：200122
Copyright © 2018 德州仪器半导体技术（上海）有限公司

PACKAGING INFORMATION

Orderable Device	Status (1)	Package Type	Package Drawing	Pins	Package Qty	Eco Plan (2)	Lead/Ball Finish (6)	MSL Peak Temp (3)	Op Temp (°C)	Device Marking (4/5)	Samples
MSP430FR2000IPW16	ACTIVE	TSSOP	PW	16	90	Green (RoHS & no Sb/Br)	NIPDAU	Level-2-260C-1 YEAR	-40 to 85	FR2000	Samples
MSP430FR2000IPW16R	ACTIVE	TSSOP	PW	16	2000	Green (RoHS & no Sb/Br)	NIPDAU	Level-2-260C-1 YEAR	-40 to 85	FR2000	Samples
MSP430FR2000IRLLR	ACTIVE	VQFN	RLL	24	3000	Green (RoHS & no Sb/Br)	NIPDAU	Level-2-260C-1 YEAR	-40 to 85	FR2000	Samples
MSP430FR2000IRLLT	ACTIVE	VQFN	RLL	24	250	Green (RoHS & no Sb/Br)	NIPDAU	Level-2-260C-1 YEAR	-40 to 85	FR2000	Samples
MSP430FR2100IPW16	ACTIVE	TSSOP	PW	16	90	Green (RoHS & no Sb/Br)	NIPDAU	Level-2-260C-1 YEAR	-40 to 85	FR2100	Samples
MSP430FR2100IPW16R	ACTIVE	TSSOP	PW	16	2000	Green (RoHS & no Sb/Br)	NIPDAU	Level-2-260C-1 YEAR	-40 to 85	FR2100	Samples
MSP430FR2100IRLLR	ACTIVE	VQFN	RLL	24	3000	Green (RoHS & no Sb/Br)	NIPDAU	Level-2-260C-1 YEAR	-40 to 85	FR2100	Samples
MSP430FR2100IRLLT	ACTIVE	VQFN	RLL	24	250	Green (RoHS & no Sb/Br)	NIPDAU	Level-2-260C-1 YEAR	-40 to 85	FR2100	Samples
MSP430FR2110IPW16	ACTIVE	TSSOP	PW	16	90	Green (RoHS & no Sb/Br)	NIPDAU	Level-2-260C-1 YEAR	-40 to 85	FR2110	Samples
MSP430FR2110IPW16R	ACTIVE	TSSOP	PW	16	2000	Green (RoHS & no Sb/Br)	NIPDAU	Level-2-260C-1 YEAR	-40 to 85	FR2110	Samples
MSP430FR2110IRLLR	ACTIVE	VQFN	RLL	24	3000	Green (RoHS & no Sb/Br)	NIPDAU	Level-2-260C-1 YEAR	-40 to 85	FR2110	Samples
MSP430FR2110IRLLT	ACTIVE	VQFN	RLL	24	250	Green (RoHS & no Sb/Br)	NIPDAU	Level-2-260C-1 YEAR	-40 to 85	FR2110	Samples
MSP430FR2111IPW16	ACTIVE	TSSOP	PW	16	90	Green (RoHS & no Sb/Br)	NIPDAU	Level-2-260C-1 YEAR	-40 to 85	FR2111	Samples
MSP430FR2111IPW16R	ACTIVE	TSSOP	PW	16	2000	Green (RoHS & no Sb/Br)	NIPDAU	Level-2-260C-1 YEAR	-40 to 85	FR2111	Samples
MSP430FR2111IRLLR	ACTIVE	VQFN	RLL	24	3000	Green (RoHS & no Sb/Br)	NIPDAU	Level-2-260C-1 YEAR	-40 to 85	FR2111	Samples
MSP430FR2111IRLLT	ACTIVE	VQFN	RLL	24	250	Green (RoHS & no Sb/Br)	NIPDAU	Level-2-260C-1 YEAR	-40 to 85	FR2111	Samples

(1) The marketing status values are defined as follows:
ACTIVE: Product device recommended for new designs.

LIFEBUY: TI has announced that the device will be discontinued, and a lifetime-buy period is in effect.

NRND: Not recommended for new designs. Device is in production to support existing customers, but TI does not recommend using this part in a new design.

PREVIEW: Device has been announced but is not in production. Samples may or may not be available.

OBSELETE: TI has discontinued the production of the device.

⁽²⁾ **RoHS:** TI defines "RoHS" to mean semiconductor products that are compliant with the current EU RoHS requirements for all 10 RoHS substances, including the requirement that RoHS substance do not exceed 0.1% by weight in homogeneous materials. Where designed to be soldered at high temperatures, "RoHS" products are suitable for use in specified lead-free processes. TI may reference these types of products as "Pb-Free".

RoHS Exempt: TI defines "RoHS Exempt" to mean products that contain lead but are compliant with EU RoHS pursuant to a specific EU RoHS exemption.

Green: TI defines "Green" to mean the content of Chlorine (Cl) and Bromine (Br) based flame retardants meet JS709B low halogen requirements of ≤ 1000 ppm threshold. Antimony trioxide based flame retardants must also meet the ≤ 1000 ppm threshold requirement.

⁽³⁾ MSL, Peak Temp. - The Moisture Sensitivity Level rating according to the JEDEC industry standard classifications, and peak solder temperature.

⁽⁴⁾ There may be additional marking, which relates to the logo, the lot trace code information, or the environmental category on the device.

⁽⁵⁾ Multiple Device Markings will be inside parentheses. Only one Device Marking contained in parentheses and separated by a "~" will appear on a device. If a line is indented then it is a continuation of the previous line and the two combined represent the entire Device Marking for that device.

⁽⁶⁾ Lead/Ball Finish - Orderable Devices may have multiple material finish options. Finish options are separated by a vertical ruled line. Lead/Ball Finish values may wrap to two lines if the finish value exceeds the maximum column width.

Important Information and Disclaimer: The information provided on this page represents TI's knowledge and belief as of the date that it is provided. TI bases its knowledge and belief on information provided by third parties, and makes no representation or warranty as to the accuracy of such information. Efforts are underway to better integrate information from third parties. TI has taken and continues to take reasonable steps to provide representative and accurate information but may not have conducted destructive testing or chemical analysis on incoming materials and chemicals. TI and TI suppliers consider certain information to be proprietary, and thus CAS numbers and other limited information may not be available for release.

In no event shall TI's liability arising out of such information exceed the total purchase price of the TI part(s) at issue in this document sold by TI to Customer on an annual basis.

TAPE AND REEL INFORMATION



QUADRANT ASSIGNMENTS FOR PIN 1 ORIENTATION IN TAPE



*All dimensions are nominal

Device	Package Type	Package Drawing	Pins	SPQ	Reel Diameter (mm)	Reel Width W1 (mm)	A0 (mm)	B0 (mm)	K0 (mm)	P1 (mm)	W (mm)	Pin1 Quadrant
MSP430FR2000IPW16R	TSSOP	PW	16	2000	330.0	12.4	6.9	5.6	1.6	8.0	12.0	Q1
MSP430FR2000IRLLR	VQFN	RLL	24	3000	330.0	12.4	3.3	3.3	1.1	8.0	12.0	Q2
MSP430FR2000IRLLT	VQFN	RLL	24	250	180.0	12.4	3.3	3.3	1.1	8.0	12.0	Q2
MSP430FR2100IPW16R	TSSOP	PW	16	2000	330.0	12.4	6.9	5.6	1.6	8.0	12.0	Q1
MSP430FR2100IRLLR	VQFN	RLL	24	3000	330.0	12.4	3.3	3.3	1.1	8.0	12.0	Q2
MSP430FR2100IRLLT	VQFN	RLL	24	250	180.0	12.4	3.3	3.3	1.1	8.0	12.0	Q2
MSP430FR2110IPW16R	TSSOP	PW	16	2000	330.0	12.4	6.9	5.6	1.6	8.0	12.0	Q1
MSP430FR2110IRLLR	VQFN	RLL	24	3000	330.0	12.4	3.3	3.3	1.1	8.0	12.0	Q2
MSP430FR2110IRLLT	VQFN	RLL	24	250	180.0	12.4	3.3	3.3	1.1	8.0	12.0	Q2
MSP430FR2111IPW16R	TSSOP	PW	16	2000	330.0	12.4	6.9	5.6	1.6	8.0	12.0	Q1
MSP430FR2111IRLLR	VQFN	RLL	24	3000	330.0	12.4	3.3	3.3	1.1	8.0	12.0	Q2
MSP430FR2111IRLLT	VQFN	RLL	24	250	180.0	12.4	3.3	3.3	1.1	8.0	12.0	Q2

TAPE AND REEL BOX DIMENSIONS

*All dimensions are nominal

Device	Package Type	Package Drawing	Pins	SPQ	Length (mm)	Width (mm)	Height (mm)
MSP430FR2000IPW16R	TSSOP	PW	16	2000	350.0	350.0	43.0
MSP430FR2000IRLLR	VQFN	RLL	24	3000	367.0	367.0	35.0
MSP430FR2000IRLLT	VQFN	RLL	24	250	210.0	185.0	35.0
MSP430FR2100IPW16R	TSSOP	PW	16	2000	350.0	350.0	43.0
MSP430FR2100IRLLR	VQFN	RLL	24	3000	367.0	367.0	35.0
MSP430FR2100IRLLT	VQFN	RLL	24	250	210.0	185.0	35.0
MSP430FR2110IPW16R	TSSOP	PW	16	2000	350.0	350.0	43.0
MSP430FR2110IRLLR	VQFN	RLL	24	3000	367.0	367.0	35.0
MSP430FR2110IRLLT	VQFN	RLL	24	250	210.0	185.0	35.0
MSP430FR2111IPW16R	TSSOP	PW	16	2000	350.0	350.0	43.0
MSP430FR2111IRLLR	VQFN	RLL	24	3000	367.0	367.0	35.0
MSP430FR2111IRLLT	VQFN	RLL	24	250	210.0	185.0	35.0



4220204/A 02/2017

NOTES:

1. All linear dimensions are in millimeters. Any dimensions in parenthesis are for reference only. Dimensioning and tolerancing per ASME Y14.5M.
2. This drawing is subject to change without notice.
3. This dimension does not include mold flash, protrusions, or gate burrs. Mold flash, protrusions, or gate burrs shall not exceed 0.15 mm per side.
4. This dimension does not include interlead flash. Interlead flash shall not exceed 0.25 mm per side.
5. Reference JEDEC registration MO-153.

EXAMPLE BOARD LAYOUT

PW0016A

TSSOP - 1.2 mm max height

SMALL OUTLINE PACKAGE



LAND PATTERN EXAMPLE
EXPOSED METAL SHOWN
SCALE: 10X



SOLDER MASK DETAILS

4220204/A 02/2017

NOTES: (continued)

- 6. Publication IPC-7351 may have alternate designs.
- 7. Solder mask tolerances between and around signal pads can vary based on board fabrication site.

EXAMPLE STENCIL DESIGN

PW0016A

TSSOP - 1.2 mm max height

SMALL OUTLINE PACKAGE



SOLDER PASTE EXAMPLE
BASED ON 0.125 mm THICK STENCIL
SCALE: 10X

4220204/A 02/2017

NOTES: (continued)

8. Laser cutting apertures with trapezoidal walls and rounded corners may offer better paste release. IPC-7525 may have alternate design recommendations.
9. Board assembly site may have different recommendations for stencil design.

MECHANICAL DATA

RLL (S-PVQFN-N24)

PLASTIC QUAD FLATPACK NO-LEAD

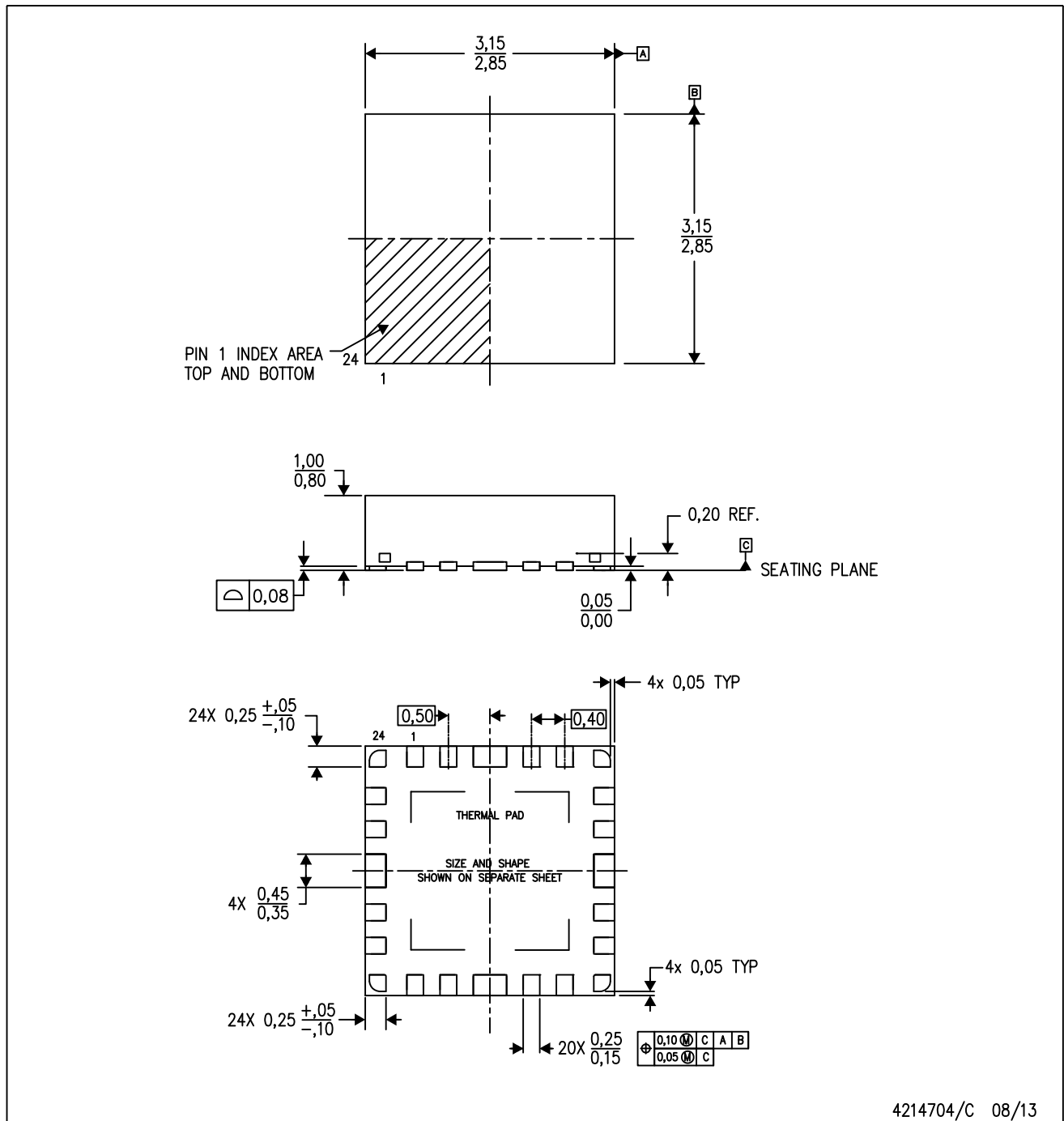

4214704/C 08/13

- NOTES:
- A. All linear dimensions are in millimeters. Dimensioning and tolerancing per ASME Y14.5M-1994.
 - B. This drawing is subject to change without notice.
 - C. Quad Flatpack, No-leads (QFN) package configuration.
 - D. The package thermal pad must be soldered to the board for thermal and mechanical performance.
 - E. See the additional figure in the Product Data Sheet for details regarding the exposed thermal pad features and dimensions.

THERMAL PAD MECHANICAL DATA

RLL (S-PVQFN-N24)

PLASTIC QUAD FLATPACK NO-LEAD

THERMAL INFORMATION

This package incorporates an exposed thermal pad that is designed to be attached directly to an external heatsink. The thermal pad must be soldered directly to the printed circuit board (PCB). After soldering, the PCB can be used as a heatsink. In addition, through the use of thermal vias, the thermal pad can be attached directly to the appropriate copper plane shown in the electrical schematic for the device, or alternatively, can be attached to a special heatsink structure designed into the PCB. This design optimizes the heat transfer from the integrated circuit (IC).

For information on the Quad Flatpack No-Lead (QFN) package and its advantages, refer to Application Report, QFN/SON PCB Attachment, Texas Instruments Literature No. SLUA271. This document is available at www.ti.com.

The exposed thermal pad dimensions for this package are shown in the following illustration.

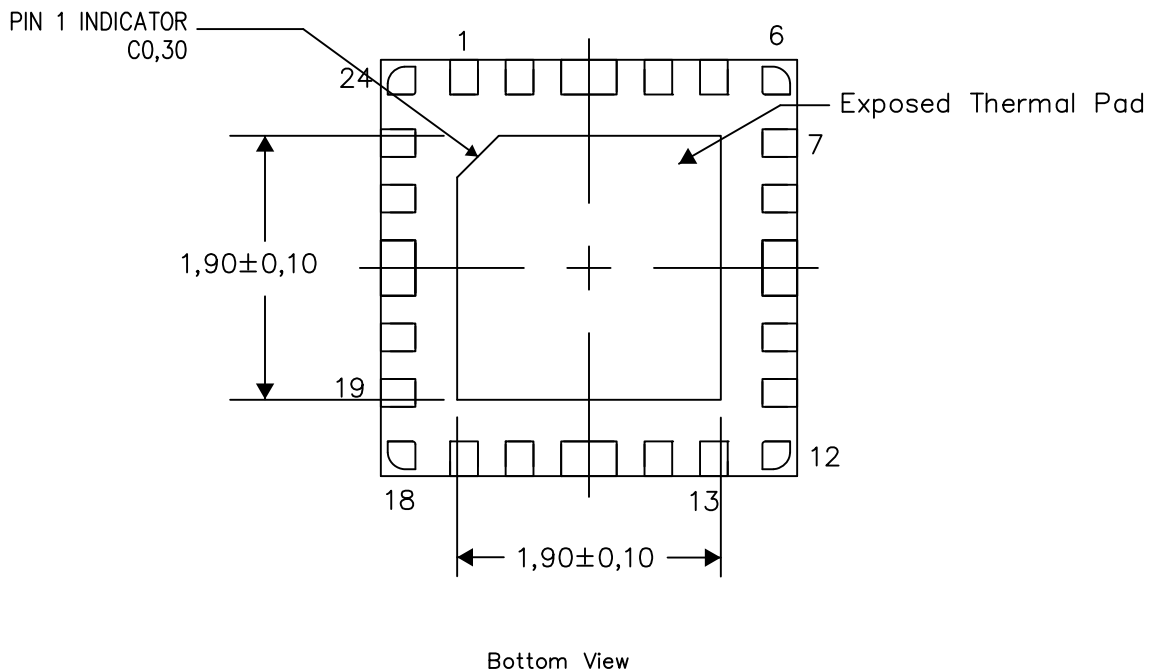

Exposed Thermal Pad Dimensions

4214706/D 08/13

NOTE: All linear dimensions are in millimeters

重要声明和免责声明

TI 均以“原样”提供技术性及其可靠性数据（包括数据表）、设计资源（包括参考设计）、应用或其他设计建议、网络工具、安全信息和其他资源，不保证其中不含任何瑕疵，且不做任何明示或暗示的担保，包括但不限于对适销性、适合某特定用途或不侵犯任何第三方知识产权的暗示担保。

所述资源可供专业开发人员应用TI 产品进行设计使用。您将对以下行为独自承担全部责任：(1) 针对您的应用选择合适的TI 产品；(2) 设计、验证并测试您的应用；(3) 确保您的应用满足相应标准以及任何其他安全、安保或其他要求。所述资源如有变更，恕不另行通知。TI 对您使用所述资源的授权仅限于开发资源所涉及TI 产品的相关应用。除此之外不得复制或展示所述资源，也不提供其它TI 或任何第三方的知识产权授权许可。如因使用所述资源而产生任何索赔、赔偿、成本、损失及债务等，TI 对此概不负责，并且您须赔偿由此对TI 及其代表造成的损害。

TI 所提供产品均受TI 的销售条款 (<http://www.ti.com.cn/zh-cn/legal/termsofsale.html>) 以及ti.com.cn 上或随附TI 产品提供的其他可适用条款的约束。TI 提供所述资源并不扩展或以其他方式更改TI 针对TI 产品所发布的可适用的担保范围或担保免责声明。

邮寄地址：上海市浦东新区世纪大道 1568 号中建大厦 32 楼，邮政编码：200122

Copyright © 2020 德州仪器半导体技术（上海）有限公司