

UCC28910 高压反激式开关 具有初级侧稳压和恒定电流控制功能

1 特性

- 无需光耦合器实现恒定电压 (CV) 和恒定电流 (CC) 输出稳压
- $\pm 5\%$ 输出电压稳压精度
- 具有交流线路和初级电感耐受补偿的 $\pm 5\%$ 输出电流稳压
- 700V 启动和智能电源管理实现小于 30mW 的同类产品中最佳待机功率
- 115kHz 最大开关频率可实现高功率密度设计
- 谷值开关和频率抖动以轻松实现电磁干扰 (EMI) 兼容性
- 热关断
- 低压线路和输出过压保护

2 应用范围

- 用于手机、平板电脑和照相机的交流和直流适配器、充电器
- 电能计量
- 电视待机开关模式电源 (SMPS)，服务器，大型家电
- LED 驱动器

4 简化电路原理图

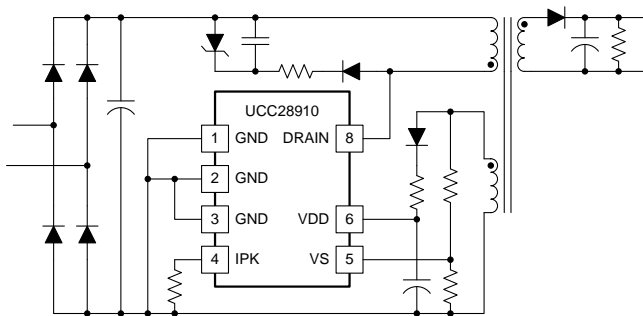

3 说明

UCC28910 专门用于隔离反激式电源，在无需光耦合器的情况下提供输出电压和电流稳压。此器件组合有一个 700V 功率场效应晶体管 (FET) 和控制器，此控制处理来自辅助反激式绕组以及功率 FET 的运行信息，以提供精准的输出电压和电流控制。

器件运行期间被关闭的集成高压电流源（用于启动），以及动态调节的控制器流耗可实现极低的待机功率。

UCC28910 内的控制算法与开关频率和峰值初级电流调制组合在一起可满足或超过适用标准的运行功效要求。具有谷值开关的断续传导模式 (DCM) 被用来减少开关损耗。最大开关频率为 115kHz。保护特性有助于在整个运行范围内限制次级和初级分量应力水平。

内部 FET 开关接通和关闭期间，DRAIN（漏）电压的受控斜坡以及频率抖动有助于减少 EMI 滤波器成本。

器件信息

订货编号	封装	封装尺寸
UCC28910D	小外形尺寸集成电路 (SOIC)-7 (7)	5mm x 6.2mm

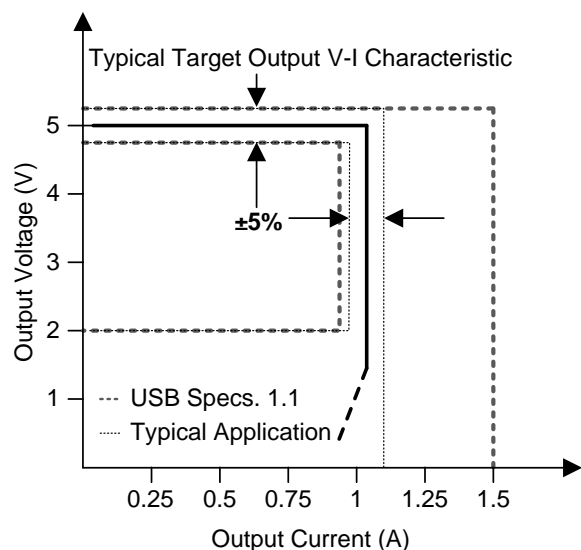

目录

1	特性	1	8.2	Functional Block Diagram	10
2	应用范围	1	8.3	Detailed Device Description	11
3	说明	1	8.4	Feature Description	14
4	简化电路原理图 简化电路原理图	1	8.5	Device Functional Modes	24
5	修订历史记录	2	9	Applications and Implementation	25
6	Terminal Configuration and Functions	3	9.1	Application Information	25
7	Specifications	4	9.2	Typical Application	25
7.1	Absolute Maximum Ratings	4	10	Power Supply Recommendations	39
7.2	Handling Ratings	4	11	Layout	39
7.3	Recommended Operating Conditions	4	11.1	Layout Guidelines	39
7.4	Thermal Information	5	11.2	Layout Example	39
7.5	Output Power	5	12	器件和文档支持	40
7.6	Electrical Characteristics	6	12.1	文档支持	40
7.7	Switching Characteristics	7	12.2	商标	40
7.8	Typical Characteristics	8	12.3	静电放电警告	40
8	Detailed Description	10	12.4	术语表	40
8.1	Overview	10	13	机械封装和可订购信息	40

5 修订历史记录

Changes from Original (July 2013) to Revision A Page

- 已更改 市场状态，从产品预览改为生产数据。

Changes from Revision A (July 2014) to Revision B Page

- 已更改 简化电路原理图

6 Terminal Configuration and Functions

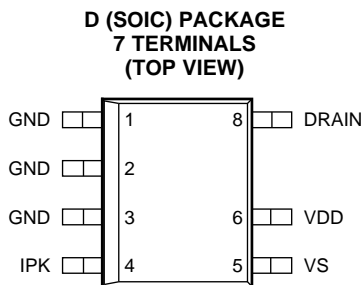

Terminal Functions

TERMINAL		I/O	DESCRIPTION
NAME	NO.		
GND	1, 2, 3	G	The ground terminals (GND) are both the reference terminals for the controller and the low-side return for the drive output. Special care should be taken to return all AC decoupling as close as possible to this terminal and avoid any common trace length with analog signal return paths.
IPK	4	I	IPK is used to set the maximum peak current flowing in the power FET that is proportional to the maximum output current.
VS	5	I	Voltage Sense (VS) is used to provide voltage and timing feedback to the controller. Normally this terminal is connected to a voltage divider between an auxiliary winding and ground. The value of the upper resistor of this divider is used to program low line thresholds.
VDD	6	P	VDD is the supply terminal to the controller. A carefully placed bypass capacitor to GND is required on this terminal.
N/A	7	N/A	This pin is not present to provide enough distance between high voltage terminal (DRAIN) and the other pins
DRAIN	8	P	DRAIN, the drain of the internal power FET, but also the input for the high-voltage current source used to start up the device.

7 Specifications

7.1 Absolute Maximum Ratings

 over operating free-air temperature range, $T_A = 25^\circ\text{C}$ (unless otherwise noted) ⁽¹⁾⁽²⁾

		MIN	MAX	UNIT
V_{DRAIN}	DRAIN voltage	Internally limited ⁽³⁾	700	V
I_{DRAIN}	Negative drain current	-100		mA
V_{DD}	Supply voltage		Internally limited ⁽³⁾	V
$I_{\text{VDD(clp)}}$	Maximum VDD clamp current		10	mA
V_{VS}	Voltage range	Internally limited ⁽³⁾	7	V
V_{IPK}	Voltage range	-0.5	5.0	V
I_{VS}	Peak vs terminal current (current out of the terminal)	1.2		mA
I_{DRAIN}	Drained pulsed drain current ⁽⁴⁾		950	mA
T_J	Operating junction temperature range	-55	150	$^\circ\text{C}$

- (1) Stresses beyond those listed under *Absolute Maximum Ratings* may cause permanent damage to the device. These are stress ratings only, which do not imply functional operation of the device at these or any other conditions beyond those indicated under *Recommended Operating Conditions*. Exposure to absolute-maximum-rated conditions for extended periods may affect device reliability.
- (2) All voltages are with respect to GND. Currents are positive into, negative out of the specified terminal. These ratings apply over the operating ambient temperature ranges unless otherwise noted.
- (3) Do not drive with low impedance voltage source.
- (4) Maximum pulse length = 100 μs .

7.2 Handling Ratings

		MIN	MAX	UNIT
T_{STG}	Storage temperature range	-65	150	$^\circ\text{C}$
	Lead temperature 1.6 mm (1/16 inch) from case for 10 seconds		260	$^\circ\text{C}$
$V_{\text{ESD}}^{(1)}$	Human Body Model (HBM) ⁽²⁾	-2000	2000	V
	Charged Device Model (CDM) ⁽²⁾	-500	500	V

- (1) Electrostatic discharge (ESD) to measure device sensitivity and immunity to damage caused by assembly line electrostatic discharges into the device.
- (2) Level listed above is the passing level per ANSI, ESDA, and JEDEC JS-001. JEDEC document JEP155 states that 500-V HBM allows safe manufacturing with a standard ESD control process.

7.3 Recommended Operating Conditions⁽¹⁾⁽²⁾

 over operating free-air temperature range (unless otherwise noted) $V_{\text{VDD}} = 15\text{ V}$, $T_A = -40^\circ\text{C}$ to 125°C , $T_A = T_J$

		MIN	NOM	MAX	UNIT
V_{VDD}		6		$V_{\text{VDD(clp)}}$	V
I_{VS}				1	mA
$I_{\text{D(peak_max)}}$			600		mA
T_J	Operating junction temperature	-40		125	$^\circ\text{C}$

- (1) Unless otherwise noted, all voltages are with respect to GND.
- (2) In case of thermal shut down, if $T_A > 100^\circ\text{C}$, the device does not restart because of the $T_{\text{J(hys)}}$ [Electrical Characteristics](#).

7.4 Thermal Information

THERMAL METRIC ⁽¹⁾		UCC28910	UNITS
		D	
		7 TERMINAL	
θ_{JA}	Junction-to-ambient thermal resistance	102.2	°C/W
θ_{JCTop}	Junction-to-case (top) thermal resistance	39.1	
θ_{JB}	Junction-to-board thermal resistance	54.7	
Ψ_{JT}	Junction-to-top characterization parameter	5.4	
Ψ_{JB}	Junction-to-board characterization parameter	54.7	

(1) For more information about traditional and new thermal metrics, see the *IC Package Thermal Metrics* application report, [SPRA953](#).

7.5 Output Power

PART NUMBER	175 V _{AC} TO 265 V _{AC}		90 V _{AC} TO 265 V _{AC}		UNIT
	ADAPTER ⁽¹⁾	OPEN FRAME ⁽²⁾	ADAPTER ⁽¹⁾	OPEN FRAME ⁽²⁾	
UCC28910	10	12	6	7.5	W

(1) Typical continuous power in enclosed adapter at 50°C ambient, with adequate (560 mm², 2 oz.) copper area connected on GND pins.

(2) Maximum continuous power with open frame design at 50°C ambient, with adequate copper area connected on GND pins and/or adequate air flow to have 50°C/W as R_{THJA}.

7.6 Electrical Characteristics

over operating free-air temperature range (unless otherwise noted), $V_{VDD} = 15\text{ V}$, $T_A = -40^\circ\text{C}$ to 125°C , $T_A = T_J$

PARAMETER		TEST CONDITIONS	MIN	TYP	MAX	UNIT
SUPPLY INPUT						
I_{RUN}	Supply current, run	$V_{VDD} = 15\text{ V}$, $V_{VS} = 3.9\text{ V}$, $f_{SW} = f_{SW(max)}$	2.3	2.9	3.4	mA
I_{RUNQ}	Quiescent supply current	$V_{VDD} = 15\text{ V}$, $V_{VS} = 3.9\text{ V}$, $f_{SW} = 0\text{ Hz}$	1.90	2.35	2.80	mA
I_{WAIT}	Wait supply current	$V_{VDD} = 15\text{ V}$, $V_{VS} = 4.1\text{ V}$, $f_{SW} = f_{SW(min)}$	150	270	370	μA
I_{WAITQ}	Quiescent wait supply current	$V_{VDD} = 15\text{ V}$, $V_{VS} = 4.1\text{ V}$, $f_{SW} = 0\text{ Hz}$	150	200	280	μA
I_{START}	Supply current before start	V_{VDD} from 0 V to 5.6 V, $V_{DRAIN} = 0\text{ V}$		65	90	μA
I_{FAULT}	Supply current after fault	$V_{VDD} = 15\text{ V}$, $f_{SW} = 0\text{ Hz}$		190	260	μA
UNDER-VOLTAGE LOCKOUT						
V_{DDON}	VDD turn-on threshold	V_{VDD} low to high	9.0	9.5	10.0	V
V_{DDOFF}	VDD turn-off threshold	V_{VDD} high to low	6.0	6.5	7.0	V
$V_{DDHV(on)}$	HV current source start	V_{VDD} high to low	4.8	5.2	5.6	V
ΔV_{UVLO}	UVLO hysteresis	$V_{DDON} - V_{DDOFF}$	2.8	3.0	3.2	V
STARTUP CURRENT SOURCE						
I_{CH1}	Startup current with VDD shorted to GND	$V_{VDD} < 250\text{ mV}$, $V_{DRAIN} = 100\text{ V}$	-300		-100	μA
I_{CH2}	Sourced current for startup at high VDD	$V_{VDD} = 8\text{ V}$, $V_{DRAIN} = 100\text{ V}$	-9.75		-0.40	mA
I_{CH3}	Sourced current for startup at low VDD	$V_{VDD} = 2\text{ V}$, $V_{DRAIN} = 100\text{ V}$	-13.75		-1.30	mA
VS INPUT						
V_{VSR}	Regulating level	Measured in no load condition, $T_J = 25^\circ\text{C}$	4.01	4.05	4.09	V
V_{VSNCL}	Negative clamp level	$I_{VS} = -300\text{ }\mu\text{A}$,	-190	-250	-325	mV
I_{VS}	Input bias current	$V_{VS} = 4\text{ V}$	-0.25	0.00	0.25	μA
PROTECTION						
I_{DOCP}	DRAIN over current	I_{PK} terminal shorted to GND	0.725	0.850	0.925	A
V_{CSTE_OCP}	Equivalent $V_{CST(OCP)}$	$V_{VS} = 3.9\text{ V}$, $I_{D(ocp)} \times R_{IPK}$	670	770	830	V
V_{CSTE_OCP2}	Equivalent $V_{CST(OCP2)}$	$V_{VS} = 3.9\text{ V}$, $I_{D(ocp2)} \times R_{IPK}$		1200		V
$t_{ONMAX(max)}$	Maximum FET on time at high load	$V_{VS} < 3.9\text{ V}$, I_{PK} shorted to GND	13	18	24	μs
$t_{ONMAX(min)}$	Maximum FET on time at low load	$V_{VS} > 4.1\text{ V}$, I_{PK} shorted to GND	4.3	6	10	μs
V_{OVP}	Over-voltage threshold	At VS input, $T_J = 25^\circ\text{C}$	4.45	4.60	4.75	V
I_{VSLRUN}	VS line sense run current	Current out of VS terminal – increasing	175	215	260	μA
$I_{VSLSTOP}$	VS line sense stop current	Current out of VS terminal – decreasing	60	75	100	μA
K_{VSL}	Line sense I_{VS} ratio	$I_{VSL(run)} / I_{VSL(stop)}$	2.55	2.70	2.90	A/A
V_{DDCLP}	VDD voltage clamp	I_{VDDCLP} forced = 2 mA	26	28	30	V
I_{VDDCLP_OC}	VDD clamp over current	$V_{VDD} > 25\text{ V}$	4.65	6.00	7.65	mA
$T_{J(stop)}$	Thermal shutdown temperature	Internal junction temperature		150		$^\circ\text{C}$
$T_{J(hys)}$	Thermal shutdown hysteresis	Internal junction temperature		50		$^\circ\text{C}$

Electrical Characteristics (continued)

over operating free-air temperature range (unless otherwise noted), $V_{DD} = 15\text{ V}$, $T_A = -40^\circ\text{C}$ to 125°C , $T_A = T_J$

PARAMETER		TEST CONDITIONS	MIN	TYP	MAX	UNIT
POWER FET						
BV_{DSS}	Break-down voltage	$T_J = 25^\circ\text{C}$	700			V
$R_{DS(on)}$	Power FET on resistance	$I_D = 150\text{ mA}$, $T_J = 25^\circ\text{C}$		10.5	12.0	Ω
		$I_D = 150\text{ mA}$, $T_J = 125^\circ\text{C}$		18.4	21.5	Ω
$I_{LEAKAGE}$	DRAIN terminal leakage current	$V_{DS} = 400\text{ V HV}$, $V_S = 4.2\text{ V DC}$ $T_J = 25^\circ\text{C}$			10	μA
		$V_{DS} = 400\text{ V HV}$, $V_S = 4.2\text{ V DC}$ $T_J = 125^\circ\text{C}$			20	μA
		$V_{DS} = 700\text{ V HV}$, $V_S = 4.2\text{ V DC}$ $T_J = 25^\circ\text{C}$				10
CURRENTS						
$I_{D_PEAK(max)}$	Maximum DRAIN peak current	$V_{DD} = 15\text{ V}$, IPK terminal shorted to GND, $T_J = 25^\circ\text{C}$	582	600	618	mA
R_{IPK_SHORT}	IPK to GND resistance Max to assume IPK shorted to GND	$V_{DD} = 15\text{ V}$			200	Ω
$R_{IPK(min)}$	IPK to GND minimum resistance	$V_{DD} = 15\text{ V}$	900			Ω
$V_{CSTE(max)}$	Equivalent current sense threshold	$V_{DD} = 15\text{ V}$, $V_{VS} = 3.9\text{ V}$, $I_{D_PK(max)} \times R_{IPK}$, $T_J = 25^\circ\text{C}$	532	540	548	V
$V_{CSTE(min)}$	Equivalent current sense threshold	$V_{DD} = 15\text{ V}$, $V_{VS} = 4.1\text{ V}$, $I_{D_PK(min)} \times R_{IPK}$	160	180	200	V
K_{AM}	AM control ratio	$V_{CSE(max)} / V_{CSE(min)}$	2.30	3.00	3.50	V/V
K_{CC}	CC regulation gain	$V_{DD} = 15\text{ V}$, $V_{VS} > 3.9\text{ V}$; $t_{DEMAG} \times f_{SW}$		0.413		
V_{CCR}	CC regulation constant	$V_{DD} = 15\text{ V}$, $V_{VS} < 3.9\text{ V}$, $V_{CSET(max)} \times K_{CC}$, $T_J = 25^\circ\text{C}$	216	223	230	V

7.7 Switching Characteristics

over operating free-air temperature range (unless otherwise noted)

PARAMETER		TEST CONDITIONS	MIN	TYP	MAX	UNIT
TIMING						
$f_{SW(max)}$	Maximum switching frequency	$V_{VS} < 3.9\text{ V}$	105	115	125	kHz
$f_{SW(min)}$	Minimum switching frequency	$V_{VS} > 4.1\text{ V}$	360	420	490	Hz
t_{ZTO}	Zero crossing timeout delay	$V_{VS} < 3.9\text{ V}$	1.80	2.10	2.65	μs
$t_{ON(min)}$	Minimum on time	$I_{PK} = 0.85\text{ V}$		390		ns

7.8 Typical Characteristics

Unless otherwise specified, $V_{DD} = 15\text{ V}$, $T_A = -40^\circ\text{C}$ to 125°C , $T_A = T_J$

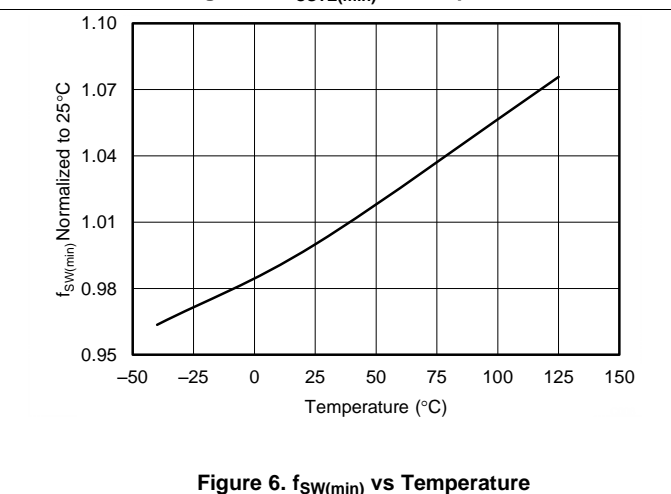
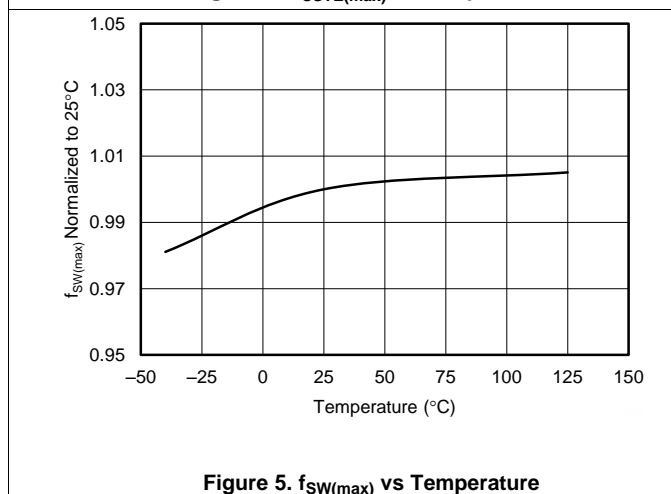
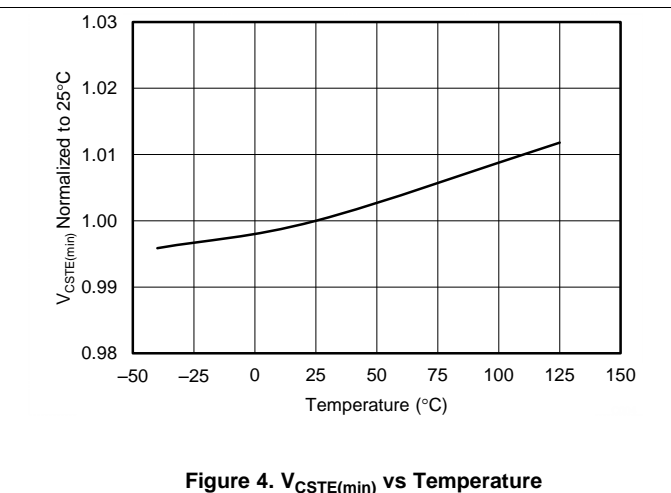
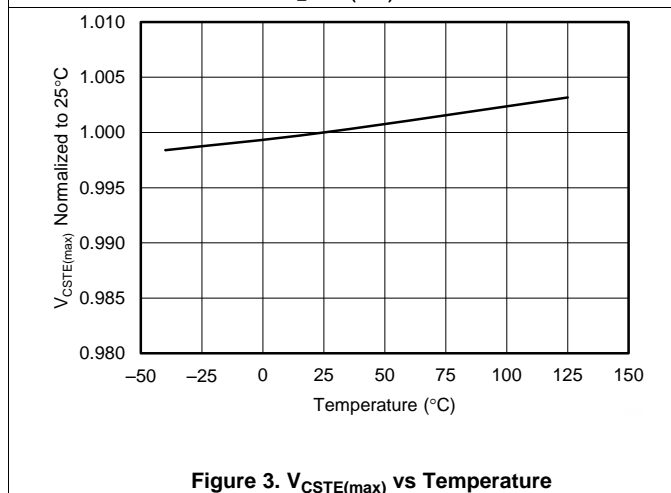
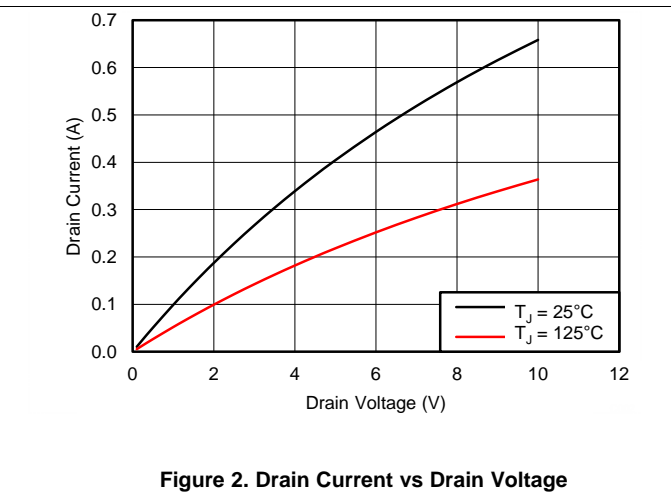
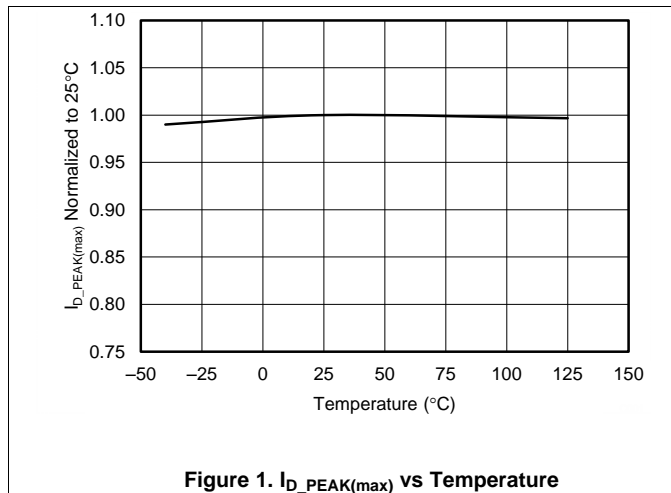

Typical Characteristics (continued)

Unless otherwise specified, $V_{DD} = 15\text{ V}$, $T_A = -40^\circ\text{C}$ to 125°C , $T_A = T_J$

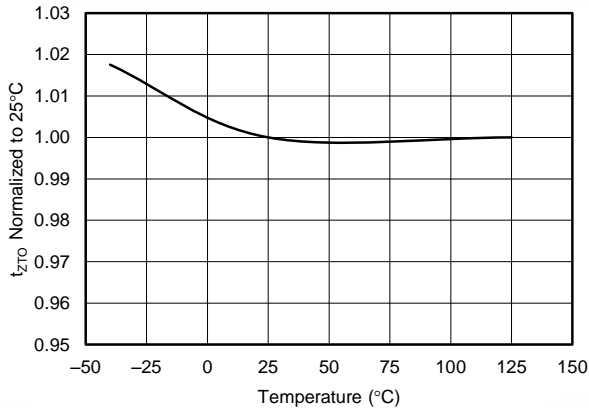

Figure 7. t_{ZTO} vs Temperature

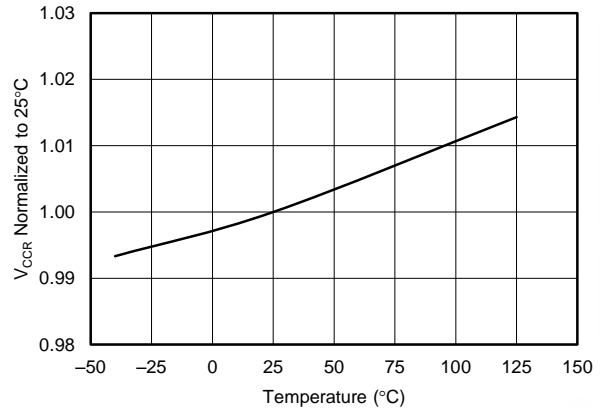

Figure 8. $V_{CSTE(min)}$ vs Temperature

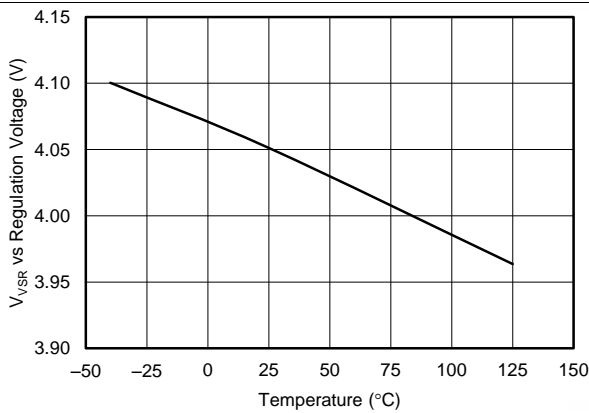

Figure 9. Regulation Voltage vs Temperature

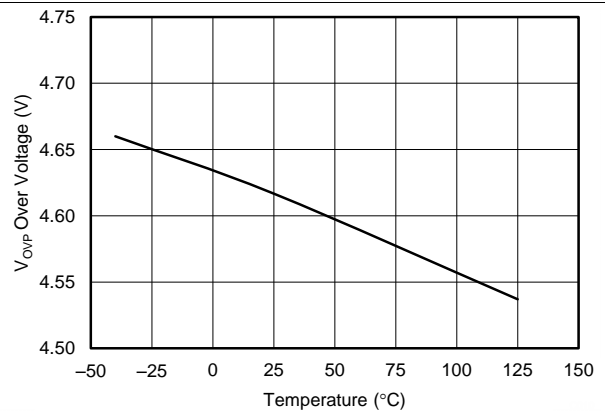

Figure 10. Over Voltage vs Temperature

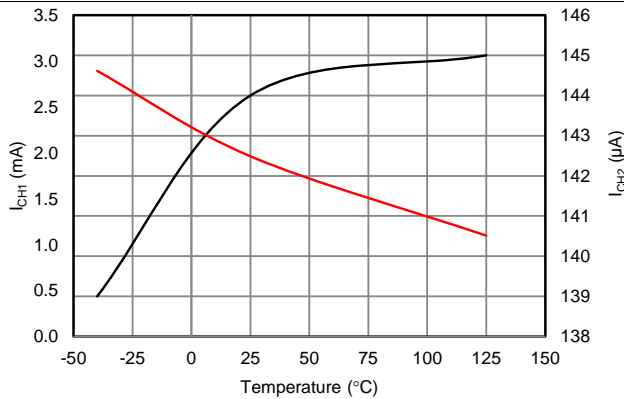

Figure 11. HV Current Source Currents

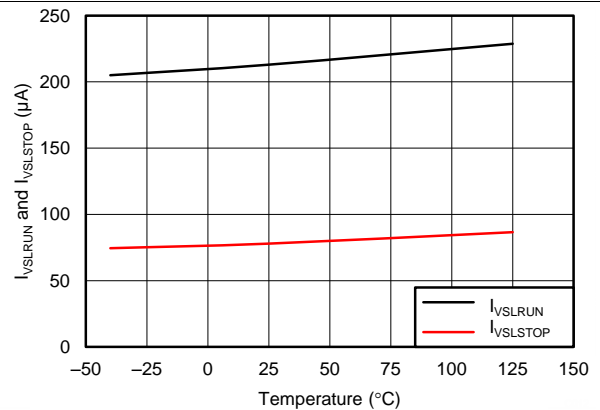

Figure 12. VS Line Sense Current vs Temperature

8 Detailed Description

8.1 Overview

The device is an HV switcher dedicated to an off-line power supply in an isolated flyback configuration. HV switcher means that device integrates the power switch, a 700-V power FET, with the control logic. The control logic controls both the output voltage and the output current without the need of an optical coupler. This control method is known as Primary-Side Regulation (PSR) and it operates by analyzing the voltage waveform on the auxiliary winding of the transformer. This allows significant cost saving with respect to traditional control scheme that uses an optical coupler. The transformer auxiliary winding is also used to provide housekeeping supply power to the control logic. The device operates in Constant Voltage mode (CV) when it is controlling the output voltage. The device operates in Constant Current mode (CC) when the output current is controlled. The device operates in CV mode or in CC mode according to the load condition. (See [Figure 18](#)). The control algorithm that implements both, modulation of the switching frequency and the amplitude modulation of the primary current peak, allows the power supply to operate efficiently over the entire load range. The high-voltage current source used for startup is kept off during normal operation thereby minimizing standby power consumption. The device also incorporates a smart power management to minimize its current consumption from the VDD terminal. This power consumption is reduced when the converter is lightly loaded or unloaded allowing for a total input power of less than 30 mW when converter input voltage is 265 V_{AC} and unloaded. A number of protection features inside the device allow for improved overall system reliability.

8.2 Functional Block Diagram

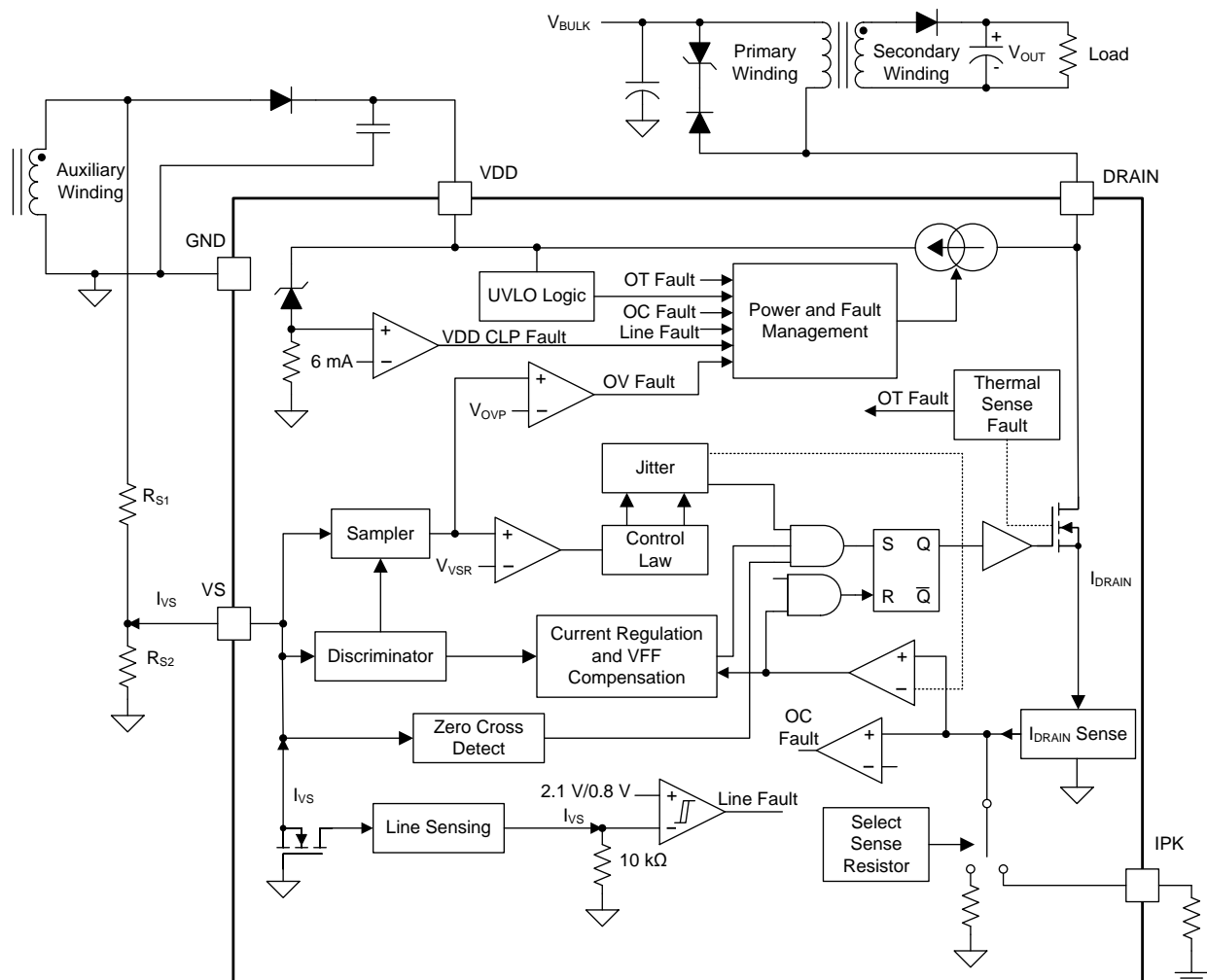

8.3 Detailed Device Description

8.3.1 VDD (Device Voltage Supply)

The VDD terminal is connected to a bypass capacitor to ground and typically to a rectifier diode connected to the auxiliary winding. The VDD turn on UVLO threshold is 9.5 V (V_{DDON} typical) and turn off UVLO threshold is 6.5 V (V_{DDOFF} typical). The terminal is provided with an internal clamp that prevents the voltage from exceeding the absolute maximum rating of the terminal. The internal clamp cannot absorb currents higher than 10 mA (see $I_{VDD(clp)}$ in [Absolute Maximum Ratings](#)), to avoid damaging the device, when the clamp flowing current exceeds 6 mA (I_{DDCLP_OC} typical) the device stops switching. The VDD terminal operating range is then from 7 V (V_{DDOFF} maximum) up to 26 V ($V_{DDCLAMP}$ minimum). The USB charging specification requires that the output current operates in constant current mode from 5 V to a minimum of 2 V; this is easily achieved with a nominal VDD of approximately 17 V. Set N_{AS} (auxiliary-to-secondary windings turn ratio) to $17\text{ V} / (V_{OUT} + V_F)$ where V_F is the voltage drop on the output diode at low current. The additional VDD headroom up to the clamp allows for VDD to rise due to the leakage energy delivered to the VDD in high-load conditions.

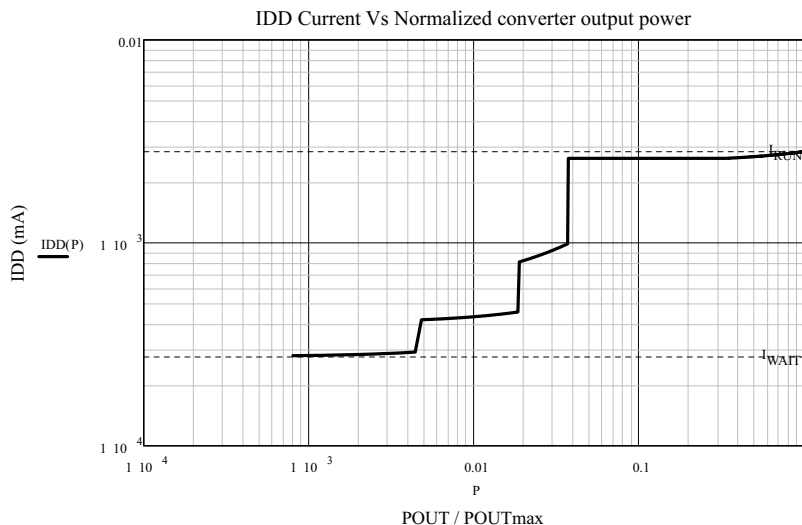

Figure 13. VDD Current Consumption

8.3.2 GND (Ground)

The device is provided with three terminals, shorted together, that are used as external ground reference to the controller for analog signal reference. The three terminals function to pull out the heat caused by the power dissipation of the internal power FET. Place the VDD bypass capacitor close to GND and VDD with short traces to minimize noise on the VS and IPK signal terminals.

Detailed Device Description (continued)

8.3.3 VS (Voltage Sense)

The VS terminal is connected to a resistor divider from the auxiliary winding to ground. The VS terminal provides three functions.

1. It provides output voltage information to the voltage control Loop. The output voltage feedback information is sampled at the end of the transformer secondary current demagnetization time to provide an accurate representation of the output voltage.
2. It also provides timing information to achieve valley switching and the duty cycle of the secondary transformer current is determined by the waveform on the VS terminal.
3. It samples the bulk capacitor input voltage providing under-voltage shutdown.

The data provided in 1) and 2) are sensed during the MOSFET off-time; 3) is performed during the MOSFET on-time when the auxiliary-winding voltage is negative.

During MOSFET on-time, the voltage on VS terminal is clamped to GND and through the resistance R_{S1} connected between the auxiliary winding and VS. During the on-time, the current sourced from the VS terminal is sensed by the device. For the under-voltage function, the enable threshold on VS current is 210 μA and the disable threshold is 75 μA .

The resistor values for R_{S1} and R_{S2} can be determined by the equations below.

$$R_{S1} = \frac{V_{\text{RMS_EN}} \times \sqrt{2}}{N_{\text{PA}} \times I_{\text{VSLRUN}}}$$

where

- N_{PA} is the transformer primary to auxiliary turns ratio,
- $V_{\text{RMS_EN}}$ is the AC RMS voltage to enable turn on of the controller,
- I_{VSLRUN} is the line sense current (210 μA typical).

$$R_{S2} = \frac{V_{\text{VSR}} \times R_{S1} \times N_{\text{PA}}}{(V_{\text{OUT}} + V_{\text{F}}) \times N_{\text{PS}} - (V_{\text{VSR}} \times N_{\text{PA}})}$$

where

- where V_{OUT} is the converter output voltage in V,
- V_{F} is the output rectifier forward drop at low current in V,
- N_{PS} is the transformer primary to secondary turns ratio R_{S1} is the VS divider high side resistance in Ohms,
- V_{VSR} is the regulating level of VS terminal.

Detailed Device Description (continued)

8.3.4 IPK (Set the Maximum DRAIN Current Peak)

A resistance (R_{IPK}) connected between IPK terminal and GND sets the maximum value of the power FET peak current. A current, I_{SENSE} , proportional to the power FET current comes out from the IPK terminal during power FET on time.

$$I_{SENSE} = \frac{I_{DRAIN}}{k_{SENSE}}$$

where

$$k_{SENSE} \cong 720$$

The voltage across R_{IPK} is fed to the PWM comparator and established to switch off the power FET according to the following equation:

$$I_{D_PK(max)} = \frac{k_{SENSE} \times V_{CST(max)}}{R_{IPK}} = \frac{V_{CSTE(max)}}{R_{IPK}}$$

where

$$V_{CST(max)} \cong 0.75\text{ V}$$

If the terminal is shorted to GND ($R_{IPK} = 0$) the peak current is automatically set to 600 mA ($I_{D_PEAK(max)}$).

A test is performed at device start up to check whether the IPK terminal is shorted to GND or the R_{IPK} is present. If R_{IPK} is less than R_{IPK_SHORT} (maximum), the device interprets it as a short ($R_{IPK} = 0$) and the DRAIN peak current is set to $I_{D_PEAK(max)}$. Otherwise, if R_{IPK} is greater than $R_{IPK(min)}$ (minimum), the device sets the peak current DRAIN according to the previous equation. A value of R_{IPK} that is in between the before said values, is not allowed since the value of the peak current may be selected using anyone of the two sense resistances: the internal sense resistance and R_{IPK} .

8.3.5 DRAIN

The DRAIN terminal is connected to the DRAIN of the internal power FET. This terminal also provides current to the high voltage current source at start up.

8.4 Feature Description

The UCC28910 is a flyback power-supply switcher which provides accurate output voltage and constant current regulation with primary-side feedback, eliminating the need for optical coupler feedback circuits. The device has an internal 700-V power FET plus a controller which forces the converter to operate in discontinuous conduction mode with valley switching to minimize switching losses. The modulation scheme is a combination of frequency and primary-peak current modulation to provide optimized conversion efficiency over the entire load range. The control law provides a wide dynamic operating range to achieve less than 30-mW standby power.

The UCC28910 includes features in the modulator to reduce the EMI peak energy of the fundamental switching frequency and harmonics. Accurate voltage and constant current regulation, fast dynamic response, and fault protection are achieved with primary-side control.

A complete charger solution can be realized with a straightforward design process, low cost and low component count solution.

8.4.1 Primary-Side Voltage Regulation

Figure 14 illustrates a flyback converter. The voltage regulation blocks of the device are shown. The power train operation is the same as any DCM flyback circuit but accurate output voltage and current sensing is the key to primary side control.

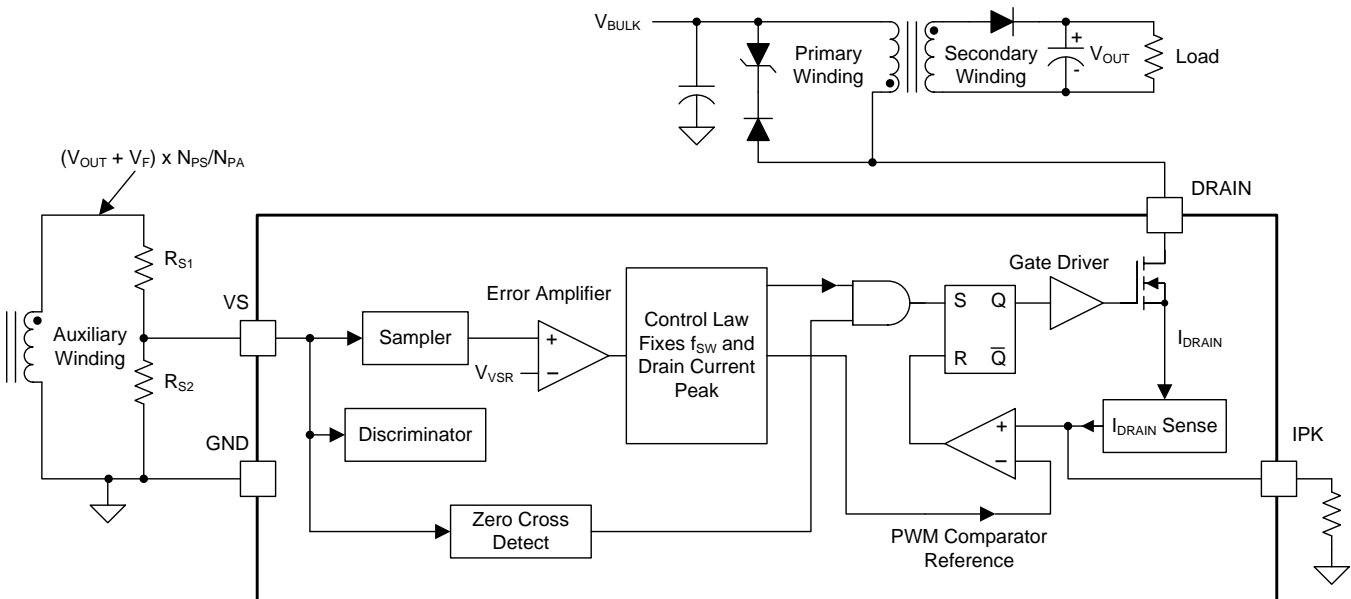

Figure 14. Voltage Loop Block Diagram

Feature Description (continued)

In primary-side control, the output voltage is sensed by the auxiliary winding during the transfer of transformer energy to the secondary. Figure 15 shows the down slope representing a decreasing total rectifier V_F and the secondary winding resistance voltage drop as the secondary current decreases to 0 A. To achieve an accurate representation of the secondary output voltage on the auxiliary winding, the *Discriminator Block* (Figure 14) reliably ignores the leakage inductance reset and ring, continuously samples the auxiliary voltage during the down slope after the ringing is diminished, and captures the error signal at the time the secondary winding reaches 0 current. The internal reference on VS is 4 V; the resistor divider is selected as outlined in the VS terminal description.

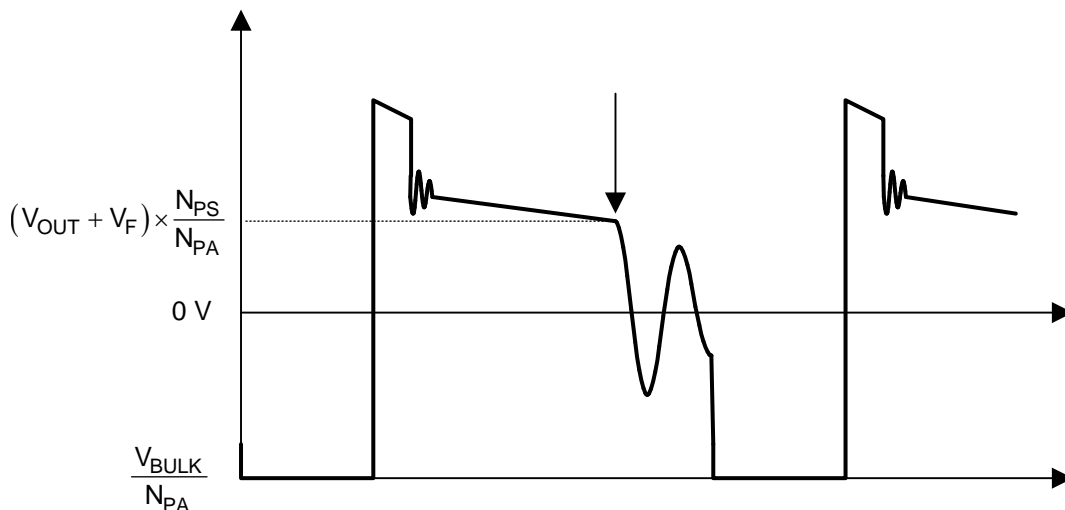

Figure 15. Auxiliary Winding Voltage

Feature Description (continued)

The UCC28910 VS signal *Discriminator Block* (Figure 14) ensures accurate sampling time for an accurate sample of the output voltage from the auxiliary winding. There are however some details of the auxiliary winding signal to ensure reliable operation, specifically the reset time of the leakage inductance and the duration of any subsequent leakage inductance ring. Refer to Figure 16 for a detailed illustration of waveform criteria to ensure a reliable sample on the VS terminal. The first detail to examine is the duration of the leakage inductance reset pedestal, t_{LK_RESET} . Since this can mimic the waveform of the secondary current decay, followed by a sharp down-slope, it is important to keep the leakage reset time less than 500 ns for I_{DRAIN} minimum, and less than 1.5 μ s for I_{DRAIN} maximum. The second detail is the amplitude of ringing on the auxiliary winding waveform (V_{AUX}) following t_{LK_RESET} . The peak-to-peak voltage at the VS terminal should be less than approximately 100 mV_{p-p} at least 200 ns before the end of the demagnetization time, t_{DMAG} . If there is a concern with excessive ringing, it usually occurs during light or no-load conditions, when t_{DMAG} is at the minimum. The tolerable ripple on VS is scaled up to the auxiliary winding voltage by R_{S1} and R_{S2} , and is equal to $100 (R_{S1} + R_{S2}) / R_{S2}$ mV.

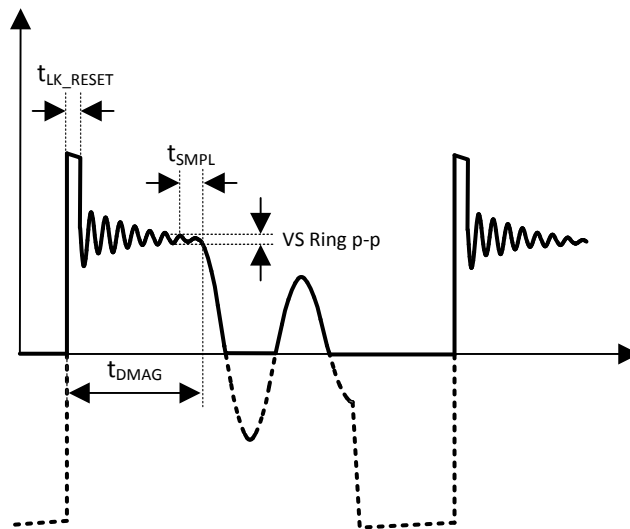

Figure 16. VS Voltage

During voltage regulation, the controller operates in frequency modulation mode and amplitude modulation mode. The internal operating frequency limits of the controller are 115 kHz maximum and 420 Hz minimum. The transformer primary inductance and turns ratio sets the maximum operating frequency of the converter. The output preload resistor and efficiency at low power determines the converter minimum operating frequency. There is no external compensation required for the UCC28910 device.

Feature Description (continued)

8.4.2 Primary-Side Current Regulation

Timing information at the VS terminal and the primary current information allow accurate regulation of the secondary average current. The control law dictates that as power is increased in CV regulation and approaching CC regulation the primary-peak current is at $I_{D_PK(max)} = V_{CSTE(max)} / R_{IPK}$. Referring to Figure 17, the primary-peak current, turns ratio, secondary demagnetization time (t_{DMAG}), and switching period (t_{SW}) establish the secondary average output current. When the average output current reaches the regulation reference in the current control block, the controller operates in frequency modulation mode to control the output current at any output voltage at or below the voltage regulation target as long as the aux winding can keep VDD above the VDD UVLO threshold (VDD_{OFF}).

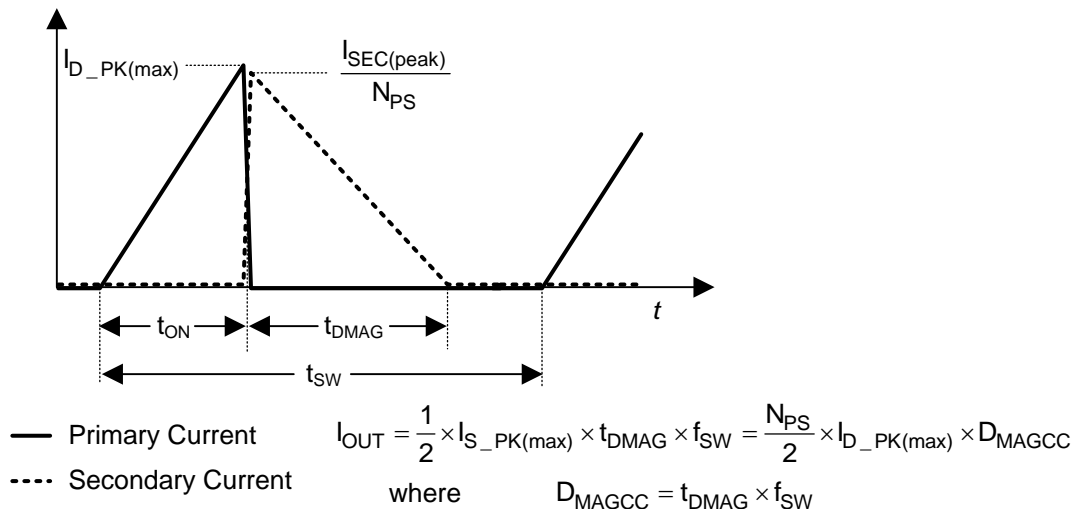

Figure 17. Output Current Estimation

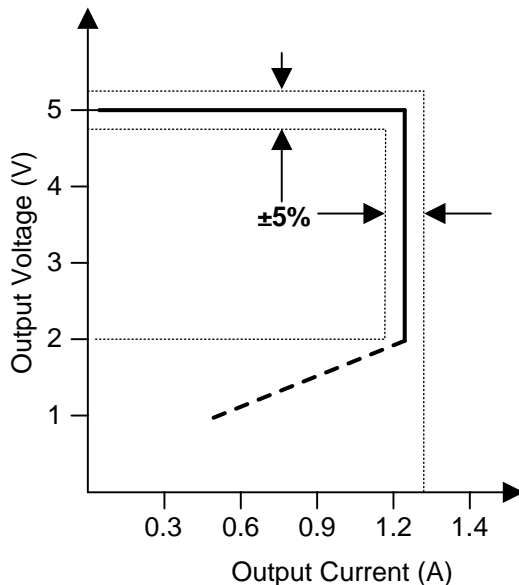

Figure 18. Target Output V-I Characteristic

Feature Description (continued)

K_{CC} is defined as the maximum value of the secondary-side conduction duty cycle. It is set internally by the UCC28910 and occurs during constant current control mode.

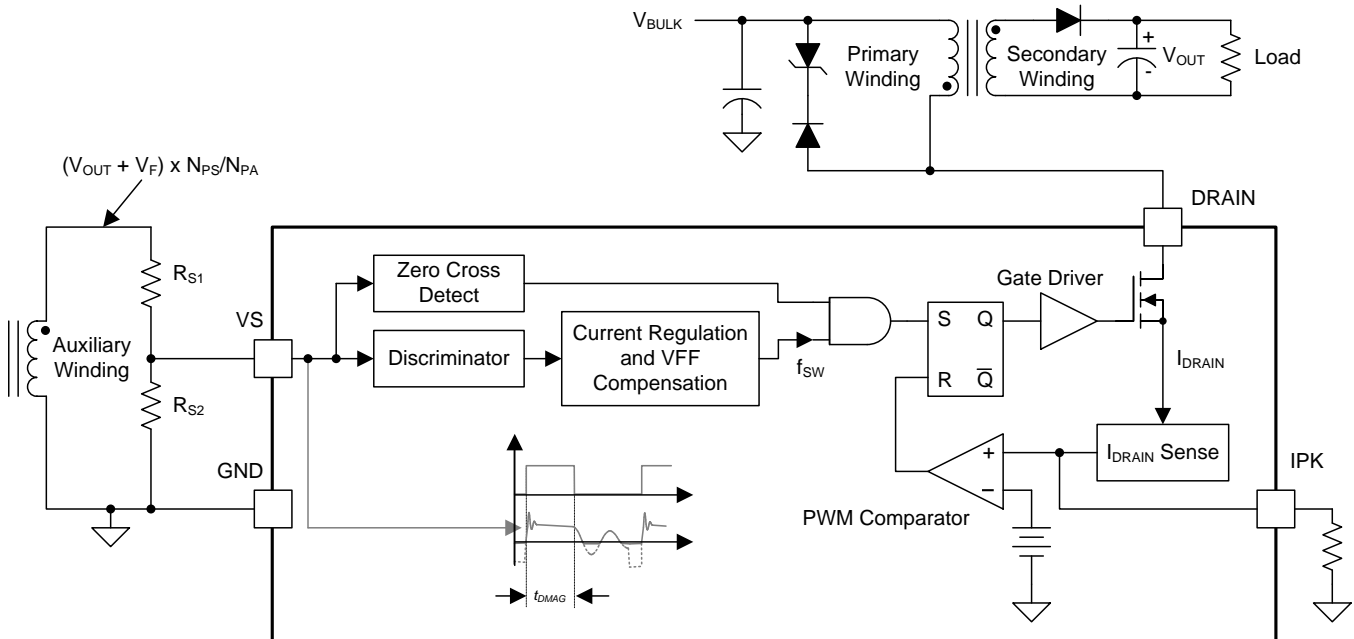

Figure 19. Output Current Control Loop Block Diagram

Feature Description (continued)

8.4.3 Voltage Feed Forward Compensation

During normal operation the on-time is determined by sensing the power FET current and switching off the power FET as this current reaches a threshold fixed by the feedback loop according to the load condition. The power FET is not immediately turned off and its current, that is also the primary winding current, continues to rise for some time during the propagation delay (t_{DELAY} in Figure 20). Keeping the reference for the PWM comparator constant, the value of the primary winding peak current depends on the slope of the primary winding current and t_{DELAY} .

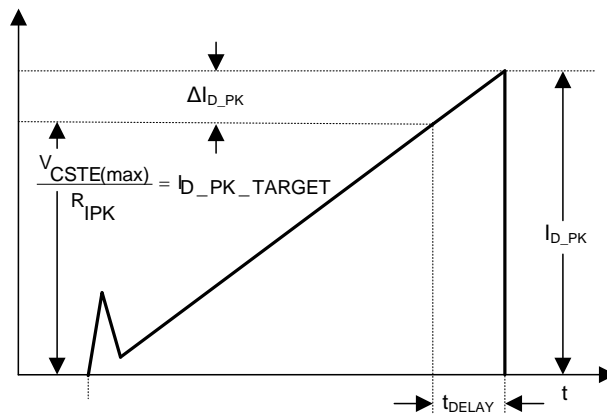

Figure 20. Propagation Delay Effect on the Primary Current Peak

$$\Delta I_{D_PK} = \frac{V_{BULK}}{L_P} \times t_{delay} \tag{5}$$

$$I_{D_PK} = I_{D_PK_TARGET} + \frac{V_{BULK}}{L_P} \times t_{delay} \tag{6}$$

The current loop estimates the output current assuming the primary winding peak current is equal to the I_{PK_TARGET} and compares this estimated current with a reference to obtain the current regulation. Considering, I_{D_PEAK} is different from $I_{D_PEAK_TARGET}$ (see Figure 20) we need to compensate the effect of the propagation delay. The UCC28910 incorporates fully integrated propagation delay compensation that modifies the switching frequency keeping the output current constant during (CC) Constant Current Mode operation. This function is integrated in the controller and requires no external components. This feature keeps the output current constant despite input voltage variations and primary inductance value spread.

Feature Description (continued)

8.4.4 Control Law

During voltage regulation, the device operates in switching frequency modulation mode and primary current peak amplitude modulation mode. The internal operating frequency limits of the device are $f_{SW(max)}$ and $f_{SW(min)}$. The transformer primary inductance and primary-peak current chosen sets the maximum operating frequency of the converter. The output preload resistor and efficiency at low power determines the converter minimum operating frequency. During constant current regulation the device operates only in frequency modulation mode reducing the switching frequency as the output voltage decreases. Figure 21 shows how the primary peak current and the switching frequency change with respect to changes in load.

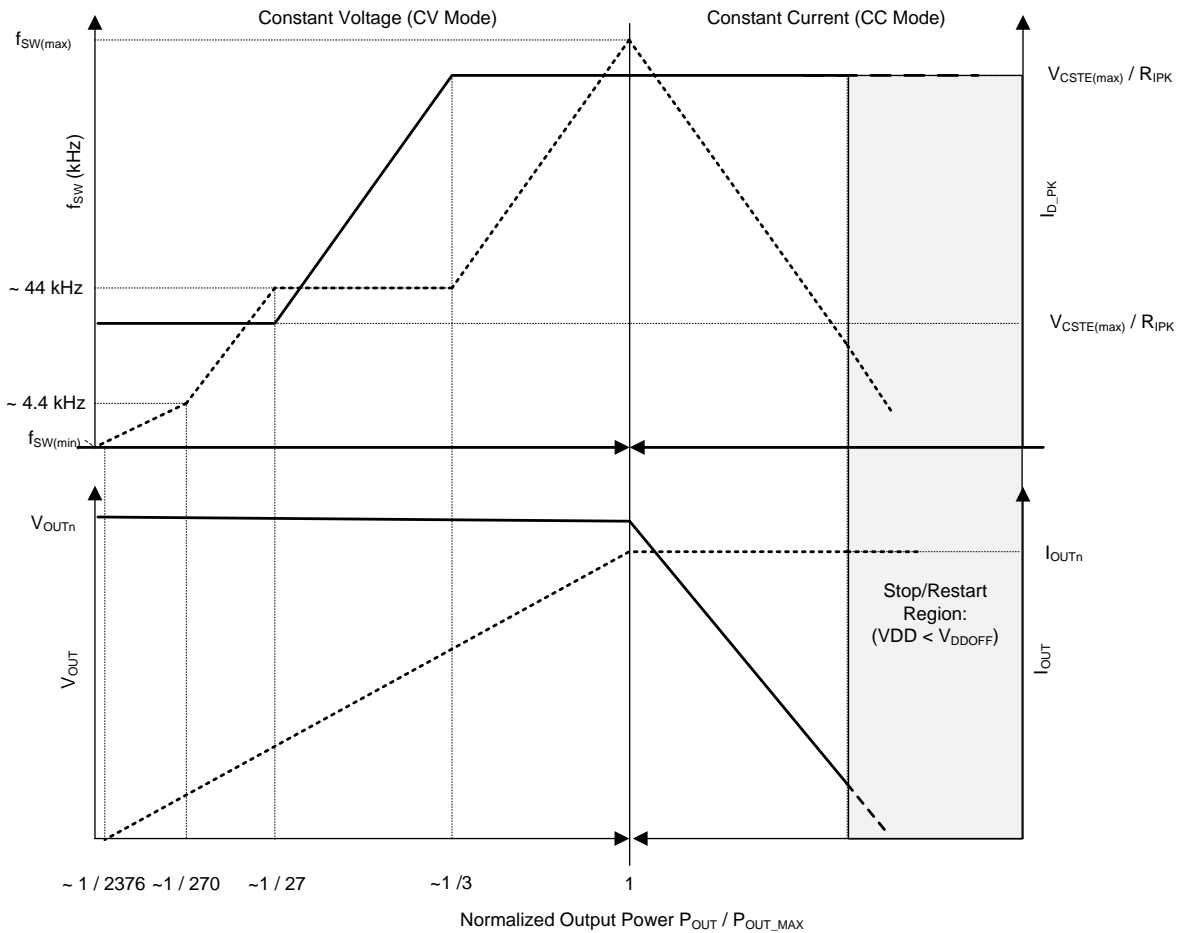

Figure 21. Control Law Profile

Feature Description (continued)

8.4.5 Valley Switching

The UCC28910 utilizes valley switching to reduce switching losses in the MOSFET and minimize the turn on FET current spike. The UCC28910 operates in valley switching in almost all load conditions until the V_{DS} ringing is diminished. By switching at the lowest V_{DS} voltage the MOSFET turn on dV / dt is minimized which is a benefit to reduce EMI.

Referring to [Figure 22](#), the UCC28910 operates in a valley skipping mode in most load conditions to maintain an accurate voltage regulation point and still switch on the lowest available V_{DS} voltage.

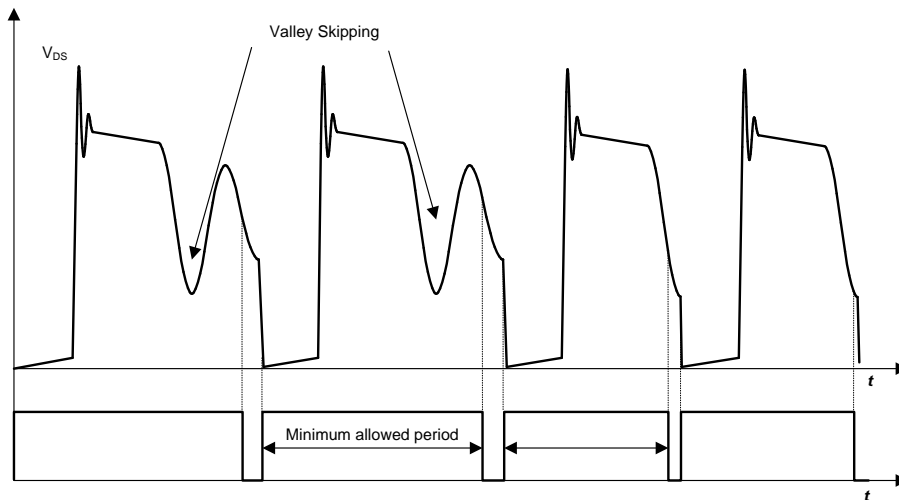

Figure 22. Valley Skipping

Valley switching is maintained during constant current regulation to provide improved efficiency and EMI benefits in constant current operation.

In very light-load or no-load condition the V_{DS} ringing is very low and not easy to detect, moreover with very low ringing amplitude there would be no benefit in valley switching so in this condition the valley switching is disabled (see [Figure 23](#)).

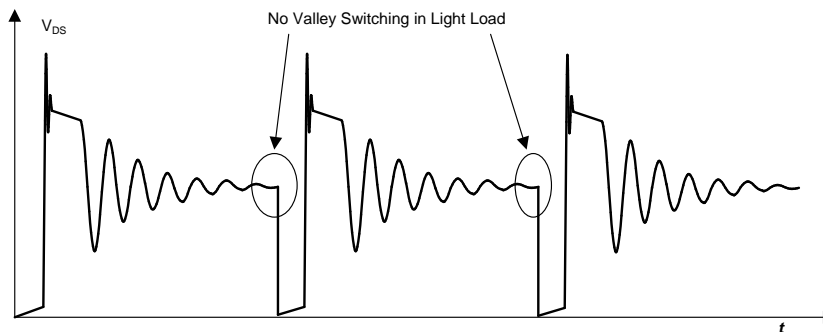

Figure 23. Valley Switching Disable at Light Load

Feature Description (continued)

8.4.6 Startup Operation

UCC28910 is provided with a high-voltage current source, connected between the DRAIN terminal and the VDD terminal; this current source is activated when a voltage is applied on DRAIN terminal. The current source charges the capacitor connected between VDD and GND increasing the VDD voltage. As VDD exceeds $V_{DD_{ON}}$ the current source is turned off and the controller internal logic is activated and the device starts switching. If the VDD voltage falls below the $V_{DD_{OFF}}$ threshold, or a fault condition is detected, the controller stops operation and its current consumption is reduced to I_{START} or I_{FAULT} . The high-voltage current source is turned on again when VDD voltage goes below $V_{DD_{HV(on)}}$ (see Figure 11 for reference).

The initial three cycles are limited to $I_{D_PEAK(max)} / 3$. This allows sensing any input or output faults with minimal power delivery. After the initial three cycles at $I_{D_PEAK(max)} / 3$, the controller responds to the condition dictated by the control law.

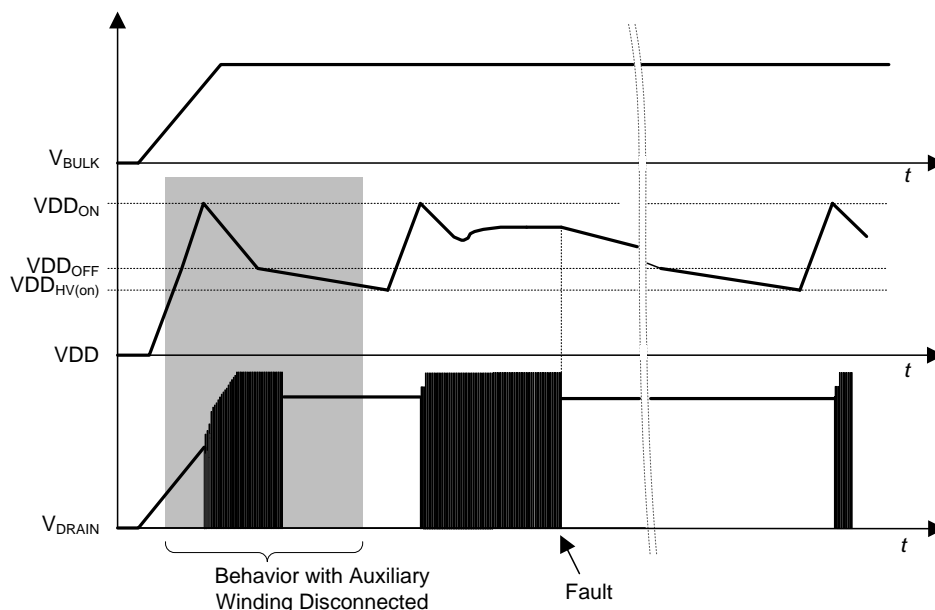

Figure 24. Start Up and Auto Re-Start Operation

The converter remains in DCM during charging of the output capacitor(s), and operates in constant current mode until the output voltage is in regulation.

To avoid high-power dissipation inside the device, such as in the event that VDD is accidentally shorted to GND, the current provided by the high-voltage current source is reduced (I_{CH1}) until $V_{DD} < 1$ V (typical).

8.4.7 Fault Protection

There is comprehensive fault protection incorporated into the UCC28910. Protection functions include:

- Output Over-Voltage Fault
- Input Under-Voltage Fault
- Internal Over-Temperature Fault
- Primary Over-Current Fault
- Maximum t_{ON} Fault
- VDD Clamp Over Current

Feature Description (continued)

8.4.7.1 Output Over-Voltage

The output over-voltage function is determined by the voltage feedback on the VS terminal. If the voltage sample on VS exceeds 4.6 V, which correlates to 115% of nominal V_{OUT} , the device stops switching and reduces its current consumption to I_{FAULT} , slowly discharging the VDD capacitor to the $VDD_{HV(on)}$ threshold. At this time the standard startup sequence begins. The initial three cycles of startup at low-peak DRAIN current is important to monitor V_{OUT} and deliver minimal power. The reset and restart, or hiccup, sequence applies for all fault protection. The slow VDD capacitor discharge after a fault allows the high voltage current source to have a low duty cycle to avoid over heating of the device if a fault condition is continuously present resulting in a repetitious start up sequence.

8.4.7.2 Input Under-Voltage

The input under voltage is determined by current information on the VS terminal during the MOSFET on time. The VS terminal is clamped close to GND during the MOSFET on time; at this time the current through R_{S1} is monitored to determine a sample of the bulk capacitor voltage. The under voltage shutdown current on VS is 75 μ A; the enable current threshold is 210 μ A. The device must sense the under-voltage condition for three consecutive switching cycles to recognize it as a fault condition. After an under-voltage fault, the same sequence described for output overvoltage occurs.

8.4.7.3 Internal Over-Temperature

The internal over-temperature protection threshold is 150°C with a hysteresis of 50°C. If an over temperature is detected the device stops switching and the current consumption is reduced to I_{FAULT} . The VDD voltage decreases to $VDD_{HV(on)}$ where the high-voltage current source is activated and the VDD voltage rises again until VDD_{ON} , where the internal logic is re-activated. If the temperature of the device is not dropped below approximately 100°C (150°C – 50°C) no switching cycles occur and the fault condition is maintained and the current consumption is again I_{FAULT} . For diagnostic purposes, when a thermal shutdown occurs, a short voltage pulse whose amplitude is around 2 V is transmitted on the IPK terminal.

8.4.7.4 Primary Over-Current

The UCC28910 always operates with cycle-by-cycle primary current control. The normal operating range for the peak DRAIN current depends on the resistance (R_{IPK}) connected between the IPK terminal and the GND terminal. The peak DRAIN current should not exceed $I_{D_PEAK(max)}$ even if the IPK terminal is shorted to GND, or should not exceed V_{CSTE} / R_{IPK} if the IPK terminal is tied to GND with the resistance R_{IPK} . There are different reasons the DRAIN current can go out of control, for example a secondary winding short or hard saturation of the transformer. To avoid over-stress of the power FET additional protections are added. If the DRAIN current exceeds I_{DOCP} (~33% higher than $I_{D_PEAK(max)}$), such as when IPK terminal is shorted to GND, or V_{CSTE_OCP} / R_{IPK} , (V_{CSTE_OCP} ~33% higher than $V_{CSTE(max)}$), and the condition is sensed for three consecutive switching cycles, a fault shutdown and retry sequence, detailed in the output overvoltage fault description, occurs. If the DRAIN current exceeds a second level of current (V_{CSTE_OCP2} / R_{IPK}) it is not necessary to detect the fault for three consecutive switching cycles, the device will stop switching immediately.

8.4.7.5 Maximum t_{ON}

An additional protection that limits the power FET on time was added. A timer sets a maximum t_{ON} time that is proportional to the I_{D_PEAK} value established by the control law. When I_{D_PEAK} is maximum the maximum t_{ON} is $t_{ONMAX(max)}$ (18 μ s typical) if I_{D_PEAK} is minimum the maximum t_{ON} is $t_{ONMAX(min)}$ (6 μ s typical). As the maximum t_{ON} is elapsed the power FET is switched off (if it is still on). If for three consecutive switching cycles the power FET is switched off by the maximum t_{ON} protection, the device stops switching and sets the consumption low ($I_{VDDFAULT}$) until the next restart.

8.4.7.6 VDD Clamp Over-Current

The VDD terminal is provided with an internal clamp to prevent the terminal voltage from exceeding the absolute maximum rating. If the current in the clamp exceeds 6 mA (typical), in order to avoid any damage to the device and to the system, a fault condition is assumed and the device stops operation.

8.5 Device Functional Modes

According to the input voltage, the VDD voltage, and the load conditions, the device can operate in different modes:

1. At start-up with $V_{\text{DRAIN}} > 20 \text{ V}$, $V_{\text{DD}} = 0 \text{ V}$, the HV voltage current source is ON and starts to charge the capacitor connected to the VDD pin. With $V_{\text{DD}} < 1 \text{ V}$ the current provided is limited $< 500 \mu\text{A}$ and VDD rises slowly.
2. When VDD exceeds 1 V ($V_{\text{DD}} < V_{\text{DD(ON)}}$) the HV current source provides higher current and VDD rises faster.
3. When VDD exceeds $V_{\text{DD(ON)}}$ the device starts switching and delivers power to its output. According to its load, the converter operates in CV mode or in CC mode.
 - (a) CV mode means that the converter keeps the output voltage constant. This operating mode takes place when $R_{\text{LOAD}} > V_{\text{OCV}} / I_{\text{OCC}}$ where V_{OCV} is the target for output voltage and I_{OCC} is the maximum converter output current. In this condition the converter output voltage $V_{\text{OUT}} = V_{\text{OCV}}$ and the converter output current $I_{\text{OUT}} < I_{\text{OCC}}$.
 - (b) CC mode means that the converter keeps the output current constant. This operating mode takes place when $R_{\text{LOAD}} < V_{\text{OCV}} / I_{\text{OCC}}$. In this condition the converter output voltage $V_{\text{OUT}} < V_{\text{OCV}}$ and the converter output current $I_{\text{OUT}} = I_{\text{OCC}}$.
4. Device operations can be stopped because of the events listed below:
 - (a) If VDD drops below $V_{\text{DD(OFF)}}$, the device stops switching and its current consumption is lowered to I_{START} . Because the converter is not switching, no energy is delivered from the auxiliary winding, the HV current source is off, then the VDD capacitor is discharged with I_{START} current.
 - (b) If a fault is detected device stops switching and its current consumption is lowered to I_{FAULT} that slowly discharges the VDD capacitor down to $V_{\text{DD(OFF)}}$ where the current consumption is $I_{\text{START}} < I_{\text{FAULT}}$ and the VDD capacitor continues to discharge.
5. After the device stops switching, because of 4a or 4b, the VDD voltage drops, when it goes below $V_{\text{DD(HV(on))}}$, the HV current source is turned on recharging the VDD capacitor up to $V_{\text{DD(ON)}}$.
6. When a fault condition is permanently present, the device operates in auto restart-mode. This means that a fault condition is detected, the device stops operation as described in 4b, then VDD drops down to $V_{\text{DD(HV(on))}}$ when the device start-up sequence takes place. At device turn-on, the fault is again detected and the cycle repeats.

9 Applications and Implementation

9.1 Application Information

The UCC28910 device is a HV switcher that integrates an HV power FET plus a controller that uses primary-side-regulated (PSR), supporting magnetically-sensed output voltage regulation via the transformer bias winding. This sensing eliminates the need for a secondary-side reference, error amplifier and optical-isolator for output voltage regulation. The device delivers accurate output voltage static load and line regulation, and accurate control of the output current. The magnetic sampling scheme allows operation only in discontinuous conduction mode (DCM) so the device is not allowed to turn on the Power FET if it doesn't sense a ZCD event that is when auxiliary winding voltage crosses zero from high to low after transformer demagnetization is complete. The modulator adjusts both frequency and peak current in different load regions to maximize efficiency throughout the operating range. The smart management of the control logic power consumption and the HV current source, used for startup that is off during operation and have very low leakage current, allow designing converters with very low standby input power. The less than 30mW can be easily achieved with this device.

9.2 Typical Application

9.2.1 Battery Charger, 5 V, 6 W

This design example describes the UCC28910FBEVM-526 design and outlines the design steps required to design a constant-voltage, constant-current flyback converter for a 5-V/6-W charger. Discontinuous conduction mode (DCM) with valley switching is used to reduce switching losses. A combination of switching frequency and peak primary current amplitude modulation is used to keep conversion efficiency high across the full load and input voltage range. Figure 25 below details the output V-I characteristic. Low system parts count and built in advanced protection features result in a cost-effective solution that meets stringent world-wide energy efficiency requirements.

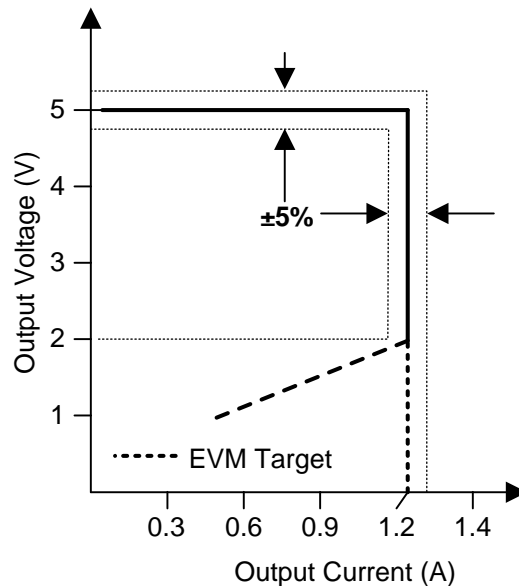

Figure 25. Target Output V-I Characteristic

Typical Application (continued)

9.2.1.1 Design Requirements

For this design example, use the parameters listed in [Table 1](#).

Table 1. Design Parameters

PARAMETER	TEST CONDITIONS	MIN	TYP	MAX	UNIT		
INPUT CHARACTERISTICS							
V_{IN}	Input voltage	85	115/230	265	V		
f_{LINE}	Frequency	47	50/60	64	Hz		
P_{NL}	No load power	$V_{IN} = V_{NOM}$, $I_{OUT} = 0$ A		15	20	mW	
V_{INUVLO}	Brownout voltage	$I_{OUT} = I_{NOM}$		70	V		
V_{INOV}	Brownout recovery voltage			80	V		
I_{IN}	Input current	$V_{IN} = V_{MIN}$, $I_{OUT} = max$		0.2	A		
OUTPUT CHARACTERISTICS							
V_{OUT}	Output voltage	$V_{IN} = V_{MIN}$ to V_{MAX} , $I_{OUT} = 0$ V to I_{NOM}		4.75	5.00	5.25	V
$I_{OUT(max)}$	Maximum output current	$V_{IN} = V_{MIN}$ to V_{MAX}		1.14	1.20	1.26	A
$I_{OUT(min)}$	Minimum output current	$V_{in} = V_{min}$ to V_{MAX}		0		A	
ΔV_{OUT}	Output voltage ripple	$V_{IN} = V_{MIN}$ to V_{MAX} , $I_{OUT} = 0$ V to I_{NOM}		150		mV	
P_{OUT}	Output power	$V_{IN} = V_{MIN}$ to V_{MAX}					
SYSTEM CHARACTERISTICS							
η	Average efficiency	25%, 50%, 75%, 100% of I_{OUT}		75%			
ENVIRONMENTAL							
Conducted EMI		Meets CISPR22B/EN55022B					

9.2.1.2 Detailed Design Procedure

This procedure outlines the steps to design a constant-voltage, constant-current flyback converter based on UCC28910 switcher. Refer to the [Figure 27](#) for component names and network locations. The design procedure equations use terms that are defined below.

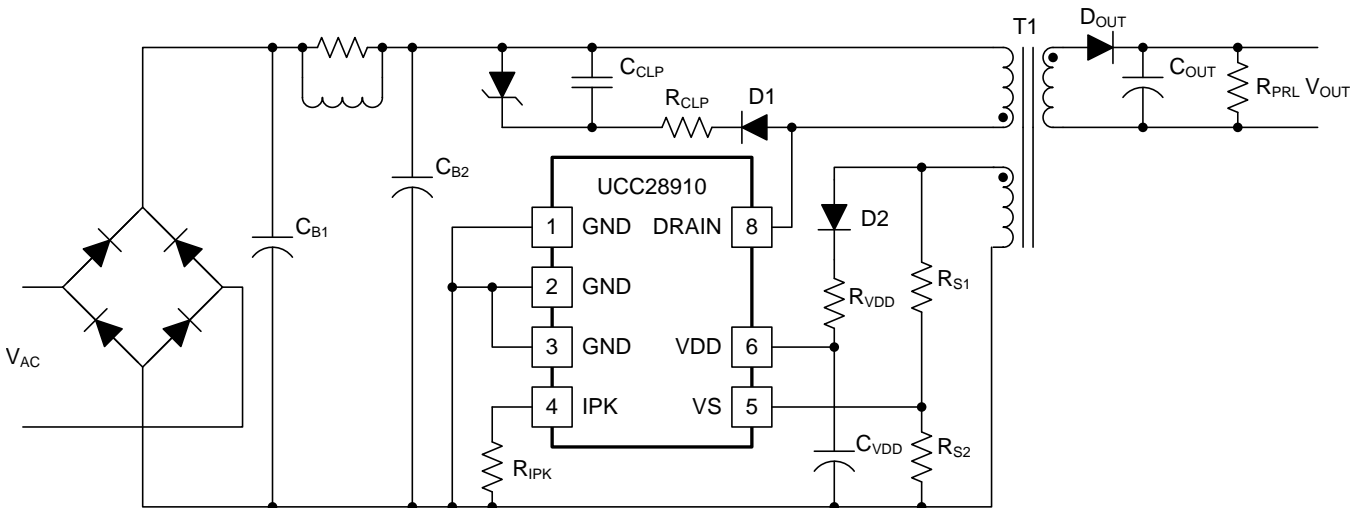

Figure 27. Standard Flyback Converter Based on UCC28910

9.2.1.2.1 Power Handling Curves

The application curves give the maximum input power that can be handled by the device versus the ambient temperature. Two input curves are shown below. The first refers to a wide-range input voltage (88 V_{AC}; 264 V_{AC}) converter; the second refers to a European range input voltage (175 V_{AC}; 265 V_{AC}) converter. The two curves refer to an AC / DC converter realized with the UCC28910 device using the provided design equations. A copper area, used as heat sink, connected to GND terminals, considered in calculation to get the Input curves is 560 mm². The input stage losses are included. A full-bridge rectifier and 7.5 Ω as inrush limiter resistance was considered.

To estimate the maximum output power at a certain ambient temperature it is possible to multiply the input power given by the input curve by the estimated efficiency. Below are reported the output power curves where, as estimated efficiency, was considered the minimum required efficiency given by EPA in to the Eligible Criteria (Version 2.0) for single voltage external AC/DC power supplies to get energy star label.

The curves give a rough estimation of the power handling capability of the device because at the end this capability depends a lot from the other components used in the circuit. A big impact on efficiency and then, on power handling capability, is given by transformer. The primary-leakage inductance and primary-winding parasitic capacitance should be minimized to improve performance.

The output diode has also an important impact; better performance is generally obtained if a Schottky diode is used because of the low-forward voltage drop and fast switching times. The reverse leakage current of this diode has to be checked because this current, in the schottky diodes, is higher respect standard or fast diodes. It increases with temperature. If the revers current is too high it could cause thermal runaway of the diode beside of the additional losses. Considering the wide-range application (Figure 30) the point representing the required output power (6 W) and operating maximum T_A (50°C) is below the 5-V curve so the device can handle the required power at the required condition.

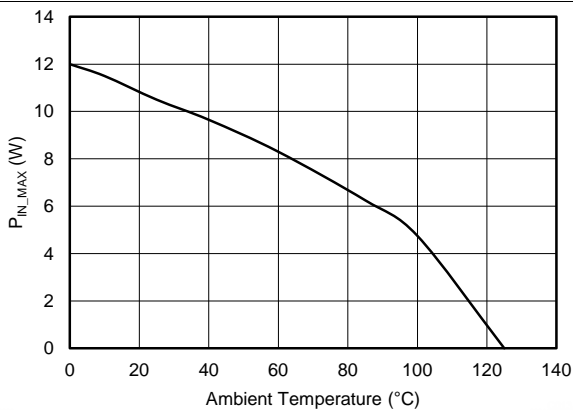

Figure 28. (90; 265) V_{RMS} Input Voltage Range Converter Maximum Input Power vs Ambient Temperature

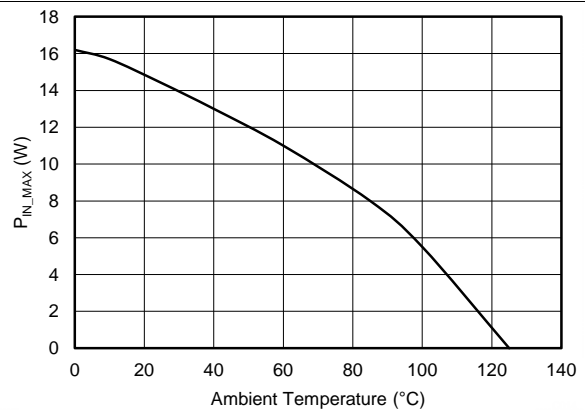

Figure 29. (180; 265) V_{RMS} Input Voltage Range Converter Maximum Input Power vs Ambient Temperature

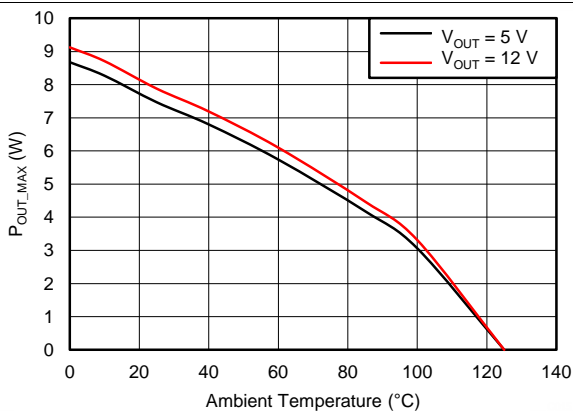

Figure 30. (90; 265) V_{RMS} Input Voltage Range Converter Maximum Output Power vs Ambient Temperature

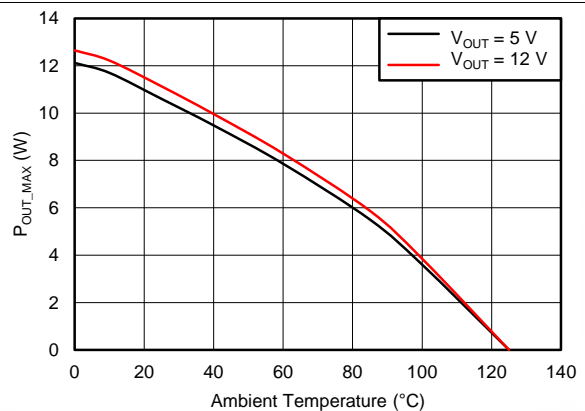

Figure 31. (180; 265) V_{RMS} Input Voltage Range Converter Maximum Output Power vs Ambient Temperature

9.2.1.2.2 Definition of Terms

Capacitance Terms in Farads

- C_{BULK} : total input capacitance of C_{B1} and C_{B2} .
- C_{VDD} : capacitance on the VDD terminal.
- C_{OUT} : output capacitance.

Duty Cycle Terms

- K_{CC} : secondary diode conduction duty cycle in CC, (see [Electrical Characteristics](#)).
- D_{MAX} : MOSFET on-time maximum duty cycle.

Frequency Terms in Hertz

- f_{LINE} : minimum line frequency.
- $f_{\text{TARGET(max)}}$: target full-load maximum switching frequency of the converter.
- f_{MIN} : minimum switching frequency of the converter, add 15% margin over the $f_{\text{SW(min)}}$ limit of the device.
- $f_{\text{SW(min)}}$: minimum switching frequency (see [Electrical Characteristics](#))

Current Terms in Amperes

- I_{OCC} : converter output current target when operating in constant current mode.
- $I_{\text{D_PK(max)}}$: maximum transformer primary current peak.
- I_{TRAN} : required positive load-step current.
- I_{RUN} : maximum current consumption of the device (see [Electrical Characteristics](#)).
- I_{VSLRUN} : VS terminal run current (see [Electrical Characteristics](#)).

Current and Voltage Scaling Terms

- K_{AM} : maximum-to-minimum peak-primary current ratio (see [Electrical Characteristics](#)).

Transformer Terms

- L_P : transformer primary inductance.
- N_{PA} : transformer primary-to-auxiliary turns ratio.
- N_{PS} : transformer primary-to-secondary turns ratio.

Power Terms in Watts

- P_{IN} : converter maximum input power.
- P_{INTRX} : transformer maximum input power.
- P_{OUT} : full-load output power of the converter.
- P_{SB} : total stand-by input power.

Resistance Terms in Ω

- R_{IPK} : primary current programming resistance.
- R_{ESR} : total ESR of the output capacitors.
- R_{PRL} : preload resistance on the output of the converter.
- R_{S1} : high-side VS terminal resistance.
- R_{S2} : low-side VS terminal resistance.

Timing Terms in Seconds

- $t_{DMAG(min)}$: minimum secondary rectifier conduction time.
- $t_{ON(min)}$: minimum MOSFET on time.
- t_R : resonant frequency during the DCM (discontinuous conduction mode) time.

Voltage Terms in Volts

- V_{BULK} : highest bulk capacitor voltage for stand-by power measurement.
- $V_{BULK(min)}$: minimum voltage on C_{B1} and C_{B2} at full power.
- V_{CCR} : constant-current regulating voltage (see [Electrical Characteristics](#)).
- V_{OD} : output voltage drop allowed during the load-step transient.
- V_{DSPK} : peak MOSFET drain-to-source voltage at high line.
- V_F : secondary rectifier, D_{OUT} , forward voltage drop at near-zero current.
- V_{FA} : auxiliary rectifier, D2, forward voltage drop.
- V_{OCV} : regulated output voltage of the converter, V_{OUT} in CV mode.
- V_{VDD} : voltage value on VDD terminal.
- V_{OCC} : target lowest converter output voltage in constant-current regulation.
- V_{REV} : peak reverse voltage on the secondary rectifier, D_{OUT} .
- V_{RIPPLE} : output peak-to-peak ripple voltage at full-load.
- V_{VSR} : CV regulating level at the VS input (see [Electrical Characteristics](#)).
- ΔV_{UVLO} : $V_{DDON} - V_{DDOFF}$ (see [Electrical Characteristics](#)).

AC Voltage Terms in V_{RMS}

- $V_{IN(max)}$: maximum AC input voltage to the converter.
- $V_{IN(min)}$: minimum AC input voltage to the converter.
- $V_{IN(run)}$: converter input start-up (run) AC voltage.

Efficiency Terms

- η : converter overall efficiency.
- η_{XFMR} : transformer primary-to-secondary power transfer efficiency.

9.2.1.2.3 Maximum Target Switching Frequency

The maximum operative switching frequency of the converter should be selected with a trade-off between the efficiency requirement (generally decreasing the switching frequency improves efficiency because the switching losses are reduced) and transformer size (increasing the switching frequency results in decreased transformer size). Some limits to the maximum value of the switching frequency need to be taken into account.

The internal oscillator of the device cannot exceed 115 kHz (see $f_{SW(max)}$ in the [Electrical Characteristics](#)) moreover the demagnetization time cannot be too short ($t_{DMAG(min)} > 1 \mu s$) in order to allow for the proper working of the discriminator (see [Primary-Side Voltage Regulation](#)) and the maximum operative switching frequency is linked to the demagnetization time from the equation below.

$$f_{TARGET(max)} < \frac{K_{AM} \times K_{CC}}{t_{DMAG(min)}} \quad (7)$$

So the target maximum operative switching frequency of the converter satisfies to the below condition:

$$f_{TARGET(max)} < \text{MIN} \left(\frac{K_{AM} \times K_{CC}}{t_{DMAG(min)}}, f_{SW(max)} \right) \quad (8)$$

A good value for $t_{DMAG(min)}$ is 1.2 μs with some margin respect the minimum allowed value.

9.2.1.2.4 Transformer Turns Ratio, Inductance, Primary-Peak Current

The maximum primary-to-secondary turns ratio can be determined by the target maximum switching frequency at full load, the minimum input capacitor bulk voltage, and the estimated DCM quasi-resonant time. Initially determine the maximum available total duty cycle of the on-time and secondary conduction time based on target switching frequency and DCM resonant time. For DCM resonant time, assume $t_R = 1 / 500$ kHz if you do not have an estimate from previous designs. For the transition mode operation limit, the period required from the end of secondary current conduction to the first valley of the V_{DS} voltage is half of the DCM resonant period, or 1 μs assuming 500-kHz resonant frequency. D_{MAX} can be determined using the equation below.

$$D_{MAX} = 1 - \left(\frac{t_R}{2} \times f_{TARGET(max)} \right) - K_{CC} \quad (9)$$

Once D_{MAX} is known, the maximum turn ratio of the primary-to-secondary can be determined with the equation below.

$$N_{PS(max)} = \frac{D_{MAX} \times V_{BULK(min)}}{K_{CC} \times (V_{OCV} + V_F)} \quad (10)$$

D_{MAGCC} is defined as the secondary diode conduction duty cycle during constant-current control mode operation. It is set internally by the UCC28910. This is the maximum allowable demagnetizing duty cycle and is equal to K_{CC} . The total voltage on the secondary winding needs to be determined; the sum of V_{OCV} and the secondary rectifier V_F . The voltage $V_{BULK(min)}$ is generally selected around 65% or 60%. $V_{BULK(min)}$ is determined by the selection of the high-voltage input capacitors.

For the 5-V USB charger applications N_{PS} values from 13 to 17 are typically used.

9.2.1.2.5 Bulk Capacitance

The minimum input capacitance voltage, the input power of the converter based on target full-load efficiency, minimum input RMS voltage, and minimum AC input frequency are used to determine the input capacitance requirement.

Maximum input power is determined based on V_{OCV} , I_{OCC} , and the full-load efficiency target.

$$P_{IN} = \frac{V_{OCV} \times I_{OCC}}{\eta} \quad (11)$$

The following equation provides an accurate solution for input capacitance based on a target minimum bulk capacitor voltage. To target a given input capacitance value, iterate the minimum capacitor voltage to achieve the target capacitance.

$$C_{BULK} = \frac{\frac{2 \times P_{IN}}{f_{LINE(min)}} \times \left(\frac{1}{RCT} - \frac{1}{2 \times \pi} \times \arccos \left(\frac{V_{BULK(min)}}{\sqrt{2} \times V_{IN(min)}} \right) \right)}{\sqrt{2} \times V_{IN(min)}^2 - V_{BULK(min)}^2} \quad (12)$$

In the case the input rectifier is a single diode (half-wave rectifier) and for bridge-input rectifier (full-wave rectifier), as in the schematic of [Figure 26](#).

9.2.1.2.6 Output Capacitance

The output capacitance value is typically determined by the transient response requirement from no load. For example, in USB charger applications, it is often required to maintain a minimum output voltage of 4.1 V with a load-step transient from 0 mA to 500 mA (I_{TRAN}). The equation below assumes that the switching frequency can be at the UCC28910 minimum of $f_{SW(min)}$.

$$C_{OUT} = \frac{I_{TRAN}}{V_{O\Delta} \times f_{SW(min)}} \quad (13)$$

Another consideration on the output capacitor(s) is the ripple voltage requirement which is reviewed based on secondary-peak current and ESR. A margin of 20% is added to the capacitor ESR requirement in the equation below.

$$R_{ESR} < \frac{V_{RIPPLE}}{I_{D_PK(max)} \times N_{PS}} \times 0.8 \quad (14)$$

9.2.1.2.7 VDD Capacitance, C_{VDD}

The capacitance on VDD needs to supply the device operating current until the output of the converter reaches the target minimum operating voltage in constant-current regulation. At this time the auxiliary winding can sustain the supply voltage to the UCC28910. The output current available to the load to charge the output capacitors is the constant-current regulation target. The equation below assumes the output current of the flyback is available to charge the output capacitance until the minimum output voltage is achieved.

$$C_{VDD} = \frac{C_{OUT} \times V_{OCC} \times I_{RUN(max)}}{I_{OCC} \times \Delta V_{UVLO}} \quad (15)$$

9.2.1.2.8 VS Resistor Divider

The VS divider resistors determine the output voltage regulation point of the flyback converter, also the high-side divider resistor (R_{S1}) determines the line voltage at which the controller enables continuous switching operation. R_{S1} is initially determined based on transformer auxiliary to primary turn ratio and desired input voltage operating threshold.

$$R_{S1} = \frac{V_{IN(min)} \times \sqrt{2}}{N_{PA} \times I_{VSLRUN(max)}} \quad (16)$$

The low-side VS terminal resistor is selected based on desired output voltage regulation.

$$R_{S2} = \frac{V_{VSR} \times R_{S1} \times N_{PA}}{(V_{OUT} + V_F) \times N_{PS} - (V_{VSR} \times N_{PA})} \quad (17)$$

9.2.1.2.9 R_{VDD} Resistor and Turn Ratio

The value of R_{VDD} and the auxiliary-to-secondary turns ratio should be selected with care in order to be sure that the VDD is always higher than the V_{DDOFF} (7 V maximum) threshold under all operating conditions. The R_{VDD} resistor also limits the current that can go into the VDD terminal preventing I_{VDDCLP_OC} clamp over-current protection from being erroneously activated.

9.2.1.2.10 Transformer Input Power

The power at the transformer input during full-load condition is given by the output power plus the power loss in the output diode plus the power consumption of the UCC28910 control logic ($V_{VDD} \times I_{RUN}$) divided by the transformer efficiency that takes into account all the losses due to the transformer: copper losses, core losses, and energy loss in the leakage inductances.

$$P_{INTRX} = \frac{(V_{OCV} + V_F) \times I_{OCC} + V_{VDD} \times I_{RUN}}{\eta_{XFMR}} \quad (18)$$

9.2.1.2.11 R_{IPK} Value

The R_{IPK} value sets the value of the DRAIN current peak that equals the transformer primary winding current peak value. This value also sets the value of the output current when working in CC mode according to the following formula:

$$I_{OUT} = \left(\sqrt{\eta_{XFMR} - \frac{V_{VDD} \times I_{RUN}}{P_{INTRX}}} \right) \times N_{PS} \times \frac{1}{2} \times I_{D_PK(max)} \times D_{MAGCC} = \left(\sqrt{\eta_{XFMR} - \frac{V_{VDD} \times I_{RUN}}{P_{INTRX}}} \right) \times N_{PS} \times \frac{1}{2} \times \frac{V_{CCR}}{R_{IPK}}$$

where

- D_{MAGCC} is the secondary diode conduction duty cycle
- N_{PS} is the primary-to-secondary transformer turns ratio
- V_{CCR} is the defined as $V_{CCR} = V_{CSTE(max)} \times K_{CC}$ and the value is specified in the [Electrical Characteristics](#) (19)

The term $\left(\sqrt{\eta_{XFMR} - \frac{V_{VDD} \times I_{RUN}}{P_{INTRX}}} \right)$ takes into account that not all the energy stored in the transformer goes to the secondary side but some of this energy, through the auxiliary winding, is used to supply the device control logic. The transfer of energy always happens with unavoidable losses. These losses are accounted for through the transformer efficiency term (η_{XFMR}). Fixed the target value for I_{OUT} , the value of R_{IPK} can be calculated using the following formula:

$$R_{IPK} = \left(\sqrt{\eta_{XFMR} - \frac{V_{VDD} \times I_{RUN}}{P_{INTRX}}} \right) \times N_{PS} \times \frac{1}{2} \times \frac{V_{CCR}}{I_{OUT}} \quad (20)$$

9.2.1.2.12 Primary Inductance Value

After you have fixed the maximum switching frequency and the maximum value of the primary current peak for your application, the primary inductance value can be fixed by the following equation:

$$L_{P(\min)} = \frac{2 \times P_{\text{INTRX}}}{(1 - L_P_Tol) \times f_{\text{TARGET}(\max)} \times I_{D_PK(\max)}^2} \quad (21)$$

L_P_Tol is the tolerance on the primary inductance value of the transformer. Typical values of L_P_Tol are between $\pm 10\%$ and $\pm 15\%$

9.2.1.2.12.1 Secondary Diode Selection

The maximum reverse voltage that the secondary diode had to sustain can be calculated by the equation below where a margin of 30% is considered. Usually for this kind of application a Schottky diode is used to reduce the power losses due to the lower forward voltage drop. The maximum current rating of the diode is generally selected between two and five times the maximum output current (I_{OCC}).

$$V_{\text{REV}} = \left(V_{\text{OCV}} + \frac{V_{\text{IN}(\max)} \times \sqrt{2}}{N_{\text{PS}}} \right) \times 1.3 \quad (22)$$

9.2.1.2.13 Pre-Load

When no load is applied on the converter output, the output voltage rises until the OVP (over voltage protection) of the device is tripped, because the device cannot operate at zero switching frequency. To avoid this, an R_{PRL} (pre-load resistance) is used. The value of this pre-load can be selected using the following equation:

$$R_{\text{PRL}} = \frac{V_{\text{OCV}}^2}{\frac{\eta_{\text{XFMR}}}{2} \times L_P \times (1 + L_P_Tol) \times f_{\text{MAX}} \times \left(\frac{I_{D_PK(\max)}}{K_{\text{AM}}} \right)^2 - V_{\text{DDOFF}(\min)} \times I_{\text{WAITQ}(\min)}} \quad (23)$$

9.2.1.2.14 DRAIN Voltage Clamp Circuit

The main purpose of this circuit, as in most flyback converters, is to prevent the DRAIN voltage from rising up to the FET break-down voltage, at the FET turn-off, and destroying the FET itself. An additional task, required by the primary-side regulation mechanism, is to provide a clean input to UCC28910 VS terminal by damping the oscillation that is typically present on the DRAIN voltage due to the transformer primary leakage inductance.

To perform damping, the D1 diode selected is not a fast recovery diode ($0.3 \mu\text{s} < t_{\text{RR}} < 1 \mu\text{s}$) so the reverse current can flow in the RLC over damped circuit. This RLC circuit is formed by the transformer primary leakage inductance (L_{LKP}), the resistance R_{CLP} , and the capacitance C_{CLP} . To ensure proper damping the resistance R_{CLP} has to satisfy the following condition:

$$R_{\text{CLP}} > 2 \times \sqrt{\frac{L_{\text{LKP}}}{C_{\text{CLP}}}} \quad (24)$$

The capacitance C_{CLP} should not be too high so it does not require too much energy to be charged. Typical values for C_{CLP} are between 100 pF and 1 nF.

If the R_{CLP} is too high, the additional drop on this resistance can cause excessively high DRAIN voltage. The DRAIN clamp circuit of Figure 27 can be modified as shown in Figure 32 where R_{CLP} was divided into resistance (R_{CLP1} and R_{CLP2}). Resistance R_{DCH} can be added to discharge the C_{CLP} capacitance before the next switching cycles. This can help in dumping oscillations caused by leakage inductance.

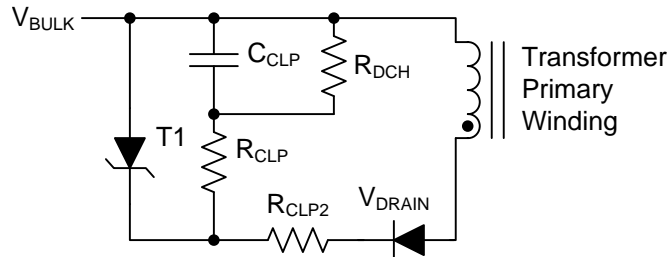

Figure 32. DRAIN Clamp Circuit Options

9.2.1.3 Application Curves

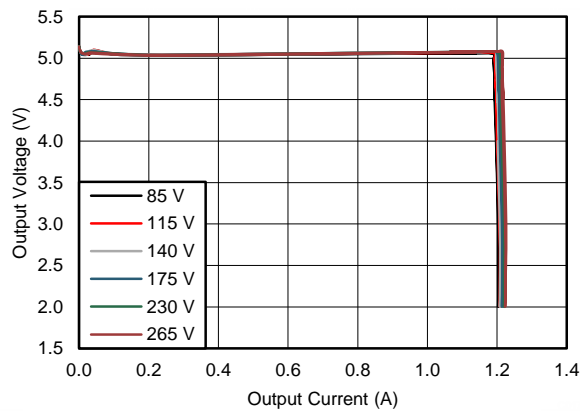

Figure 33. Output V-I Characteristic

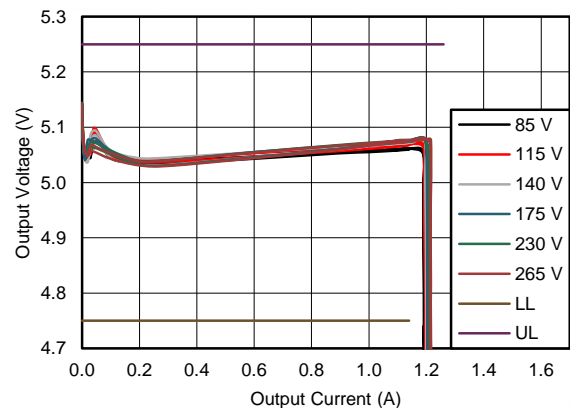

Figure 34. Output V-I Characteristic Output Current Regulation

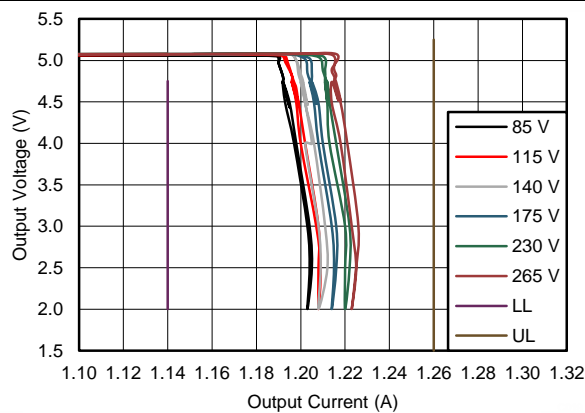

Figure 35. Output V-I Characteristic Output Voltage Regulation

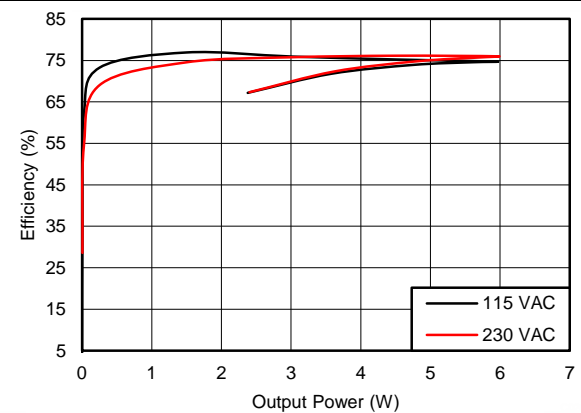

Figure 36. Efficiency vs P_{OUT} Diagram

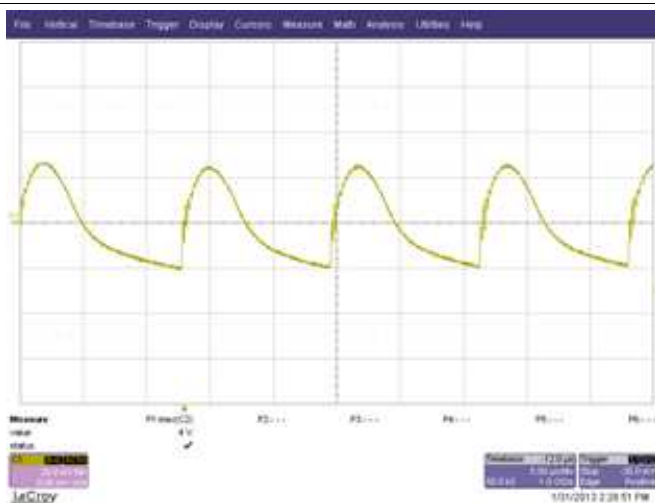

Figure 37. Ripple with 5-V, 1.2-A Output, 85 V_{AC} Input, 20 mV/div, 5 μ s/div

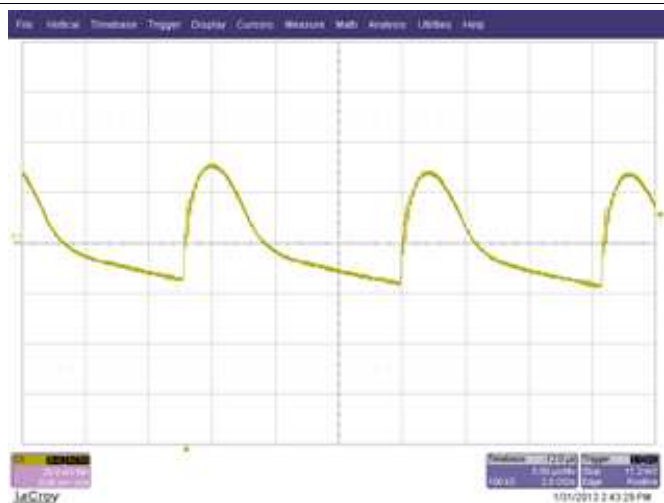

Figure 38. Ripple with 5-V, 1.2-A Output, 265-V_{AC} Input, 20 mV/div 5 μ s/div

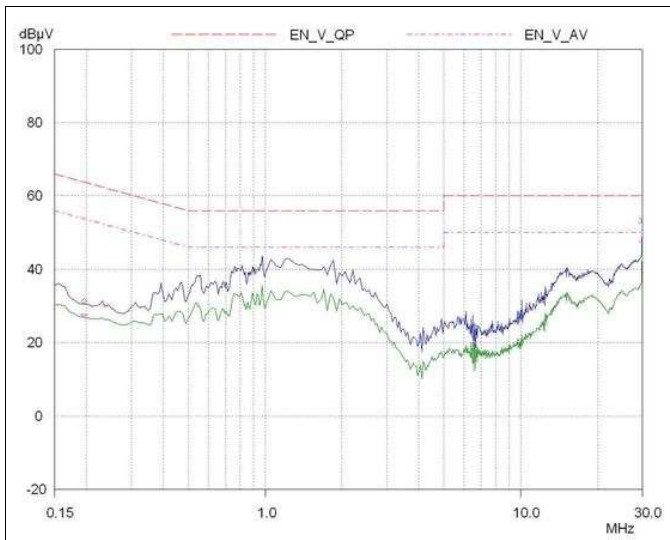

Figure 39. EMI Test Results per EN55022, Class B. 115 V_{AC} Input

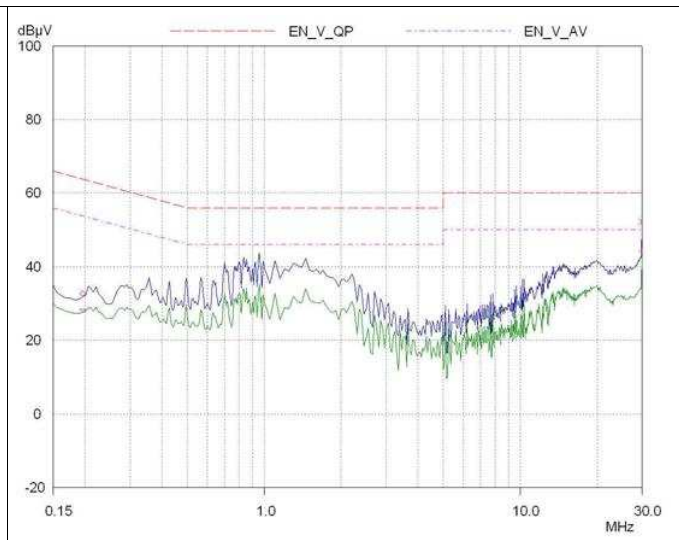

Figure 40. EMI Test Results per EN55022, Class B. 230-V_{AC} Input

9.2.1.4 Average Efficiency Performance and Standby Power of the UCC28910FBEVM-526

Table 2 summarizes the average efficiency performance of the UCC28910FBEVM-526 and Table 3 summarizes the standby power that is the no-load power consumption of the converter.

Table 2. Average Efficiency Performance of the UCC28910FBEVM-526

V_{IN} (V)	f (Hz)	P_{IN} (W)	I_{OUT} (A)	V_{OUT} (V)	P_{OUT} (W)	EFFICIENCY (%)	AVERAGE EFFICIENCY (%)
115	60	7.826	1.201	4.950	5.943	75.94	76.25
		5.845	0.901	4.942	4.451	76.15	
		3.889	0.601	4.934	2.964	76.19	
		1.930	0.301	4.927	1.481	76.73	
230	50	7.721	1.201	4.956	5.950	77.06	76.68
		5.783	0.901	4.948	4.457	77.07	
		3.853	0.601	4.938	2.966	76.97	
		1.960	0.301	4.930	1.482	75.60	

Table 3. Standby Power, No-Load Power Consumption of the Converter

V_{IN} (V)	f (Hz)	P_{IN} (mW)
88	60	10
115	60	10
230	50	10
265	50	12

10 Power Supply Recommendations

The UCC28910 is intended for AC/DC adapters and chargers with input voltage range of 85 V_{AC(rms)} to 265 V_{AC(rms)} using Flyback topology. It can be used in other applications and converter topologies with different input voltages. Be sure that all voltages and currents are within the recommended operating conditions and absolute maximum ratings of the device.

To maintain output current regulation over the entire input voltage range, design the converter to operate close to f_{MAX} when in full-load conditions.

To improve thermal performance increase the copper area connected to GND pins.

11 Layout

11.1 Layout Guidelines

In order to increase the reliability and feasibility of the project it is recommended to follow the here below guidelines.

1. Place the R_{IPK} resistance as close as possible to the device with the shortest available traces.
2. Try to minimize the area of DRAIN trace, this helps in keeping EMI disturbance low.
3. A copper area connected to the GND terminals improves heat sinking thermal performance.
4. A copper area connected to anode and cathode secondary diode improves heat sinking with an emphasis on the quiet area of the diode, the diode connected to the output capacitor, this limits the EMI disturbance.
5. Place the auxiliary voltage sense resistor divider (R_{S1} and R_{S2} in Figure 41) directly on the VS pin keeping traces as short as possible.

11.2 Layout Example

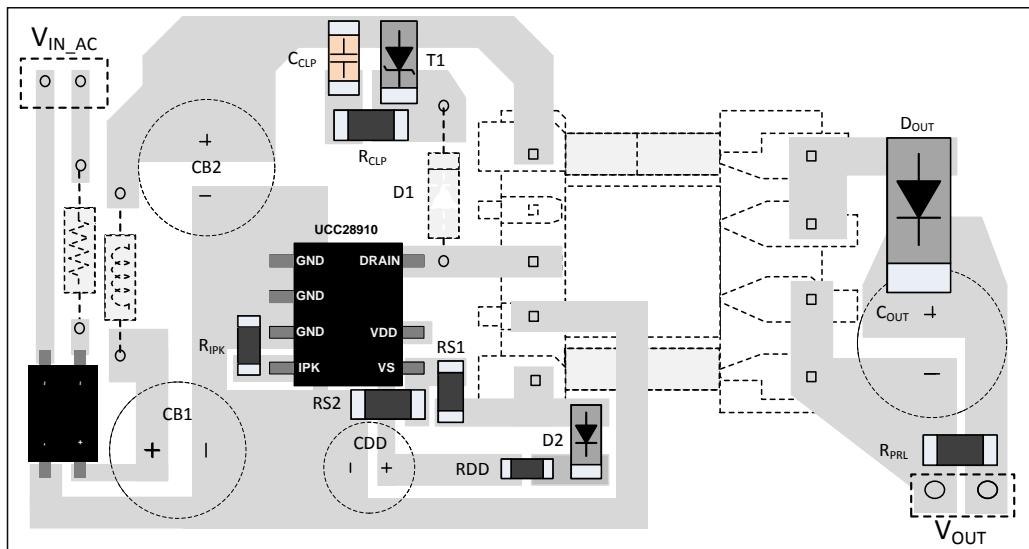

Figure 41. UCC28910 Layout Example

12 器件和文档支持

12.1 文档支持

12.1.1 相关文档

使用 *UCC28910 EVM-526*，评估模块，德州仪器 (TI) 文献编号 [SLUUA14](#)

12.2 商标

All trademarks are the property of their respective owners.

12.3 静电放电警告



这些装置包含有限的内置 ESD 保护。存储或装卸时，应将导线一起截短或将装置放置于导电泡棉中，以防止 MOS 门极遭受静电损伤。

12.4 术语表

[SLYZ022](#) — *TI* 术语表。

这份术语表列出并解释术语、首字母缩略词和定义。

13 机械封装和可订购信息

以下页中包括机械封装和可订购信息。 这些信息是针对指定器件可提供的最新数据。 这些数据会在无通知且不对本文档进行修订的情况下发生改变。 欲获得该数据表的浏览器版本，请查阅左侧的导航栏。

重要声明

德州仪器(TI)及其下属子公司有权根据 JESD46 最新标准,对所提供的产品和服务进行更正、修改、增强、改进或其它更改,并有权根据 JESD48 最新标准中止提供任何产品和服务。客户在下订单前应获取最新的相关信息,并验证这些信息是否完整且是最新的。所有产品的销售都遵循在订单确认时所提供的TI 销售条款与条件。

TI 保证其所销售的组件的性能符合产品销售时 TI 半导体产品销售条件与条款的适用规范。仅在 TI 保证的范围内,且 TI 认为有必要时才会使用测试或其它质量控制技术。除非适用法律做出了硬性规定,否则没有必要对每种组件的所有参数进行测试。

TI 对应用帮助或客户产品设计不承担任何义务。客户应对其使用 TI 组件的产品和应用自行负责。为尽量减小与客户产品和应用相关的风险,客户应提供充分的设计与操作安全措施。

TI 不对任何 TI 专利权、版权、屏蔽作品权或其它与使用了 TI 组件或服务的组合设备、机器或流程相关的 TI 知识产权中授予的直接或隐含权限作出任何保证或解释。TI 所发布的与第三方产品或服务有关的信息,不能构成从 TI 获得使用这些产品或服务的许可、授权、或认可。使用此类信息可能需要获得第三方的专利权或其它知识产权方面的许可,或是 TI 的专利权或其它知识产权方面的许可。

对于 TI 的产品手册或数据表中 TI 信息的重要部分,仅在没有对内容进行任何篡改且带有相关授权、条件、限制和声明的情况下才允许进行复制。TI 对此类篡改过的文件不承担任何责任或义务。复制第三方的信息可能需要服从额外的限制条件。

在转售 TI 组件或服务时,如果对该组件或服务参数的陈述与 TI 标明的参数相比存在差异或虚假成分,则会失去相关 TI 组件或服务的所有明示或暗示授权,且这是不正当的、欺诈性商业行为。TI 对任何此类虚假陈述均不承担任何责任或义务。

客户认可并同意,尽管任何应用相关信息或支持仍可能由 TI 提供,但他们将独立负责满足与其产品及其在应用中使用的 TI 产品相关的所有法律、法规和安全相关要求。客户声明并同意,他们具备制定与实施安全措施所需的全部专业技术和知识,可预见故障的危险后果、监测故障及其后果、降低有可能造成人身伤害的故障的发生机率并采取适当的补救措施。客户将全额赔偿因在此类安全关键应用中使用任何 TI 组件而对 TI 及其代理造成的任何损失。

在某些场合中,为了推进安全相关应用有可能对 TI 组件进行特别的促销。TI 的目标是利用此类组件帮助客户设计和创立其特有的可满足适用的功能安全性标准和要求的终端产品解决方案。尽管如此,此类组件仍然服从这些条款。

TI 组件未获得用于 FDA Class III (或类似的生命攸关医疗设备)的授权许可,除非各方授权官员已经达成了专门管控此类使用的特别协议。

只有那些 TI 特别注明属于军用等级或“增强型塑料”的 TI 组件才是设计或专门用于军事/航空应用或环境的。购买者认可并同意,对并非指定面向军事或航空航天用途的 TI 组件进行军事或航空航天方面的应用,其风险由客户单独承担,并且由客户独立负责满足与此类使用相关的所有法律和法规要求。

TI 已明确指定符合 ISO/TS16949 要求的产品,这些产品主要用于汽车。在任何情况下,因使用非指定产品而无法达到 ISO/TS16949 要求, TI 不承担任何责任。

	产品		应用
数字音频	www.ti.com.cn/audio	通信与电信	www.ti.com.cn/telecom
放大器和线性器件	www.ti.com.cn/amplifiers	计算机及周边	www.ti.com.cn/computer
数据转换器	www.ti.com.cn/dataconverters	消费电子	www.ti.com.cn/consumer-apps
DLP® 产品	www.dlp.com	能源	www.ti.com.cn/energy
DSP - 数字信号处理器	www.ti.com.cn/dsp	工业应用	www.ti.com.cn/industrial
时钟和计时器	www.ti.com.cn/clockandtimers	医疗电子	www.ti.com.cn/medical
接口	www.ti.com.cn/interface	安防应用	www.ti.com.cn/security
逻辑	www.ti.com.cn/logic	汽车电子	www.ti.com.cn/automotive
电源管理	www.ti.com.cn/power	视频和影像	www.ti.com.cn/video
微控制器 (MCU)	www.ti.com.cn/microcontrollers		
RFID 系统	www.ti.com.cn/rfidsys		
OMAP应用处理器	www.ti.com/omap		
无线连通性	www.ti.com.cn/wirelessconnectivity	德州仪器在线技术支持社区	www.deyisupport.com

邮寄地址: 上海市浦东新区世纪大道1568号, 中建大厦32楼邮政编码: 200122
Copyright © 2015, 德州仪器半导体技术(上海)有限公司

PACKAGING INFORMATION

Orderable Device	Status (1)	Package Type	Package Drawing	Pins	Package Qty	Eco Plan (2)	Lead/Ball Finish (6)	MSL Peak Temp (3)	Op Temp (°C)	Device Marking (4/5)	Samples
UCC28910D	ACTIVE	SOIC	D	7	75	Green (RoHS & no Sb/Br)	NIPDAU	Level-2-260C-1 YEAR	-40 to 125	U28910	Samples
UCC28910DR	ACTIVE	SOIC	D	7	2500	Green (RoHS & no Sb/Br)	NIPDAU	Level-2-260C-1 YEAR	-40 to 125	U28910	Samples

(1) The marketing status values are defined as follows:

ACTIVE: Product device recommended for new designs.

LIFEBUY: TI has announced that the device will be discontinued, and a lifetime-buy period is in effect.

NRND: Not recommended for new designs. Device is in production to support existing customers, but TI does not recommend using this part in a new design.

PREVIEW: Device has been announced but is not in production. Samples may or may not be available.

OBsolete: TI has discontinued the production of the device.

(2) **RoHS:** TI defines "RoHS" to mean semiconductor products that are compliant with the current EU RoHS requirements for all 10 RoHS substances, including the requirement that RoHS substance do not exceed 0.1% by weight in homogeneous materials. Where designed to be soldered at high temperatures, "RoHS" products are suitable for use in specified lead-free processes. TI may reference these types of products as "Pb-Free".

RoHS Exempt: TI defines "RoHS Exempt" to mean products that contain lead but are compliant with EU RoHS pursuant to a specific EU RoHS exemption.

Green: TI defines "Green" to mean the content of Chlorine (Cl) and Bromine (Br) based flame retardants meet JS709B low halogen requirements of <=1000ppm threshold. Antimony trioxide based flame retardants must also meet the <=1000ppm threshold requirement.

(3) MSL, Peak Temp. - The Moisture Sensitivity Level rating according to the JEDEC industry standard classifications, and peak solder temperature.

(4) There may be additional marking, which relates to the logo, the lot trace code information, or the environmental category on the device.

(5) Multiple Device Markings will be inside parentheses. Only one Device Marking contained in parentheses and separated by a "-" will appear on a device. If a line is indented then it is a continuation of the previous line and the two combined represent the entire Device Marking for that device.

(6) Lead/Ball Finish - Orderable Devices may have multiple material finish options. Finish options are separated by a vertical ruled line. Lead/Ball Finish values may wrap to two lines if the finish value exceeds the maximum column width.

Important Information and Disclaimer:The information provided on this page represents TI's knowledge and belief as of the date that it is provided. TI bases its knowledge and belief on information provided by third parties, and makes no representation or warranty as to the accuracy of such information. Efforts are underway to better integrate information from third parties. TI has taken and continues to take reasonable steps to provide representative and accurate information but may not have conducted destructive testing or chemical analysis on incoming materials and chemicals. TI and TI suppliers consider certain information to be proprietary, and thus CAS numbers and other limited information may not be available for release.

In no event shall TI's liability arising out of such information exceed the total purchase price of the TI part(s) at issue in this document sold by TI to Customer on an annual basis.

TAPE AND REEL INFORMATION



QUADRANT ASSIGNMENTS FOR PIN 1 ORIENTATION IN TAPE



*All dimensions are nominal

Device	Package Type	Package Drawing	Pins	SPQ	Reel Diameter (mm)	Reel Width W1 (mm)	A0 (mm)	B0 (mm)	K0 (mm)	P1 (mm)	W (mm)	Pin1 Quadrant
UCC28910DR	SOIC	D	7	2500	330.0	12.4	6.4	5.2	2.1	8.0	12.0	Q1

TAPE AND REEL BOX DIMENSIONS



*All dimensions are nominal

Device	Package Type	Package Drawing	Pins	SPQ	Length (mm)	Width (mm)	Height (mm)
UCC28910DR	SOIC	D	7	2500	367.0	367.0	35.0



D0007A

PACKAGE OUTLINE

SOIC - 1.75 mm max height

SMALL OUTLINE INTEGRATED CIRCUIT

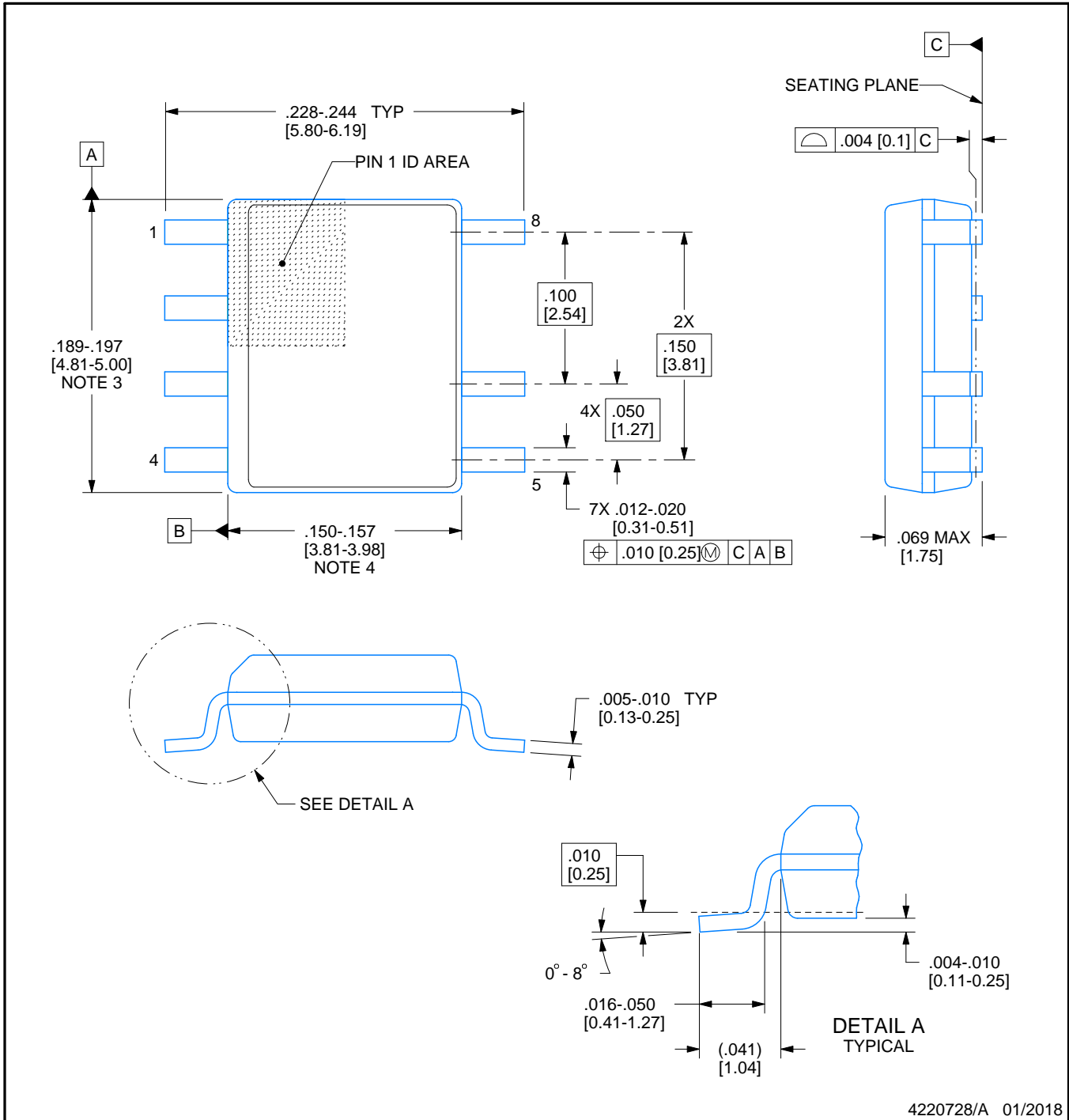

NOTES:

1. Linear dimensions are in inches [millimeters]. Dimensions in parenthesis are for reference only. Controlling dimensions are in inches. Dimensioning and tolerancing per ASME Y14.5M.
2. This drawing is subject to change without notice.
3. This dimension does not include mold flash, protrusions, or gate burrs. Mold flash, protrusions, or gate burrs shall not exceed $.006$ [0.15] per side.
4. This dimension does not include interlead flash.
5. Reference JEDEC registration MS-012, variation AA.

EXAMPLE BOARD LAYOUT

D0007A

SOIC - 1.75 mm max height

SMALL OUTLINE INTEGRATED CIRCUIT

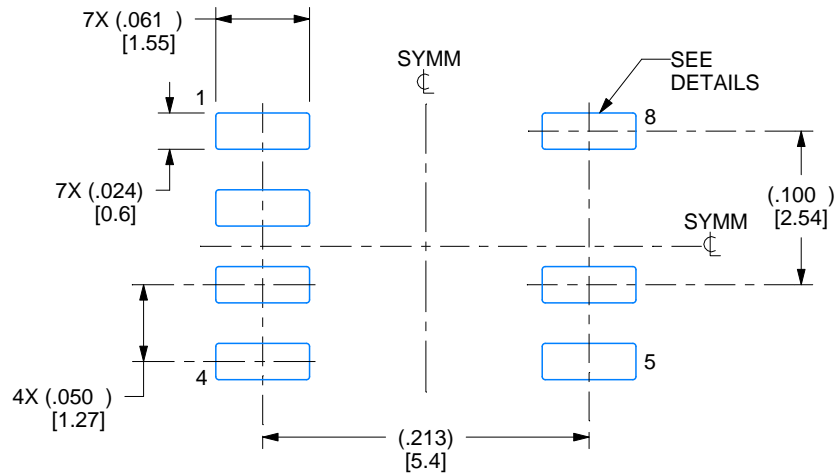

LAND PATTERN EXAMPLE
EXPOSED METAL SHOWN
SCALE:8X

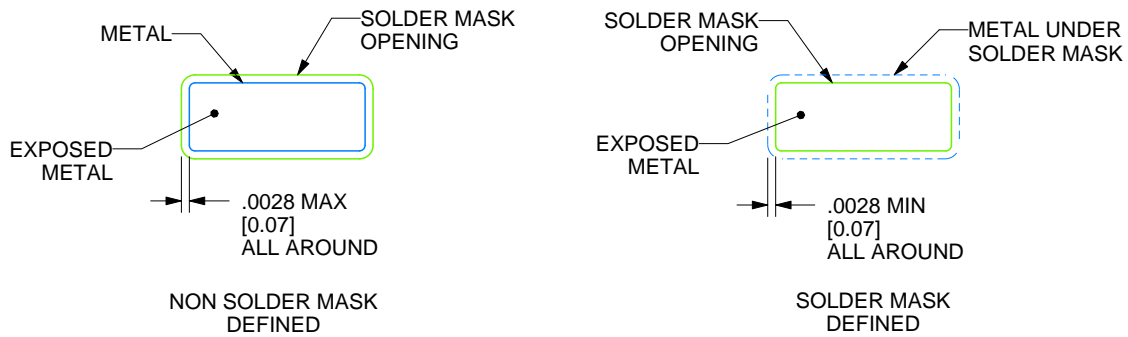

SOLDER MASK DETAILS

4220728/A 01/2018

NOTES: (continued)

6. Publication IPC-7351 may have alternate designs.

7. Solder mask tolerances between and around signal pads can vary based on board fabrication site.

EXAMPLE STENCIL DESIGN

D0007A

SOIC - 1.75 mm max height

SMALL OUTLINE INTEGRATED CIRCUIT

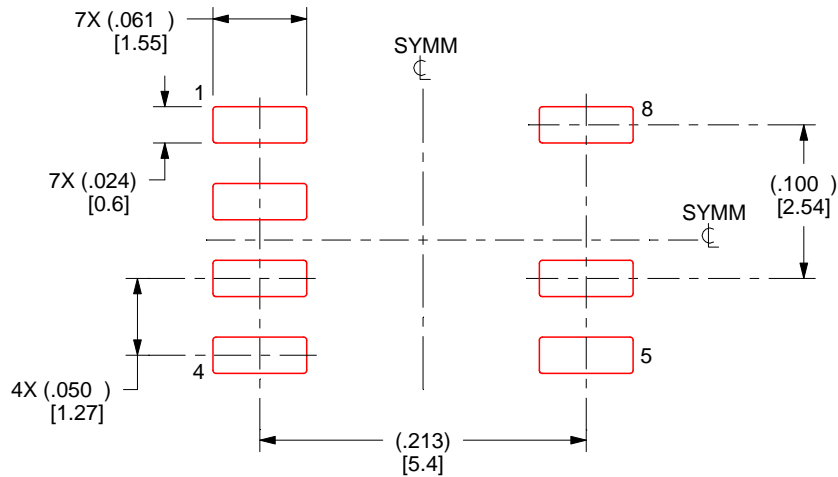

SOLDER PASTE EXAMPLE
BASED ON .005 INCH [0.125 MM] THICK STENCIL
SCALE:8X

4220728/A 01/2018

NOTES: (continued)

8. Laser cutting apertures with trapezoidal walls and rounded corners may offer better paste release. IPC-7525 may have alternate design recommendations.
9. Board assembly site may have different recommendations for stencil design.

重要声明和免责声明

TI 均以“原样”提供技术性 & 可靠性数据（包括数据表）、设计资源（包括参考设计）、应用或其他设计建议、网络工具、安全信息和其他资源，不保证其中不含任何瑕疵，且不做任何明示或暗示的担保，包括但不限于对适销性、适合某特定用途或不侵犯任何第三方知识产权的暗示担保。

所述资源可供专业开发人员应用 TI 产品进行设计使用。您将对以下行为独自承担全部责任：(1) 针对您的应用选择合适的 TI 产品；(2) 设计、验证并测试您的应用；(3) 确保您的应用满足相应标准以及任何其他安全、安保或其他要求。所述资源如有变更，恕不另行通知。TI 对您使用所述资源的授权仅限于开发资源所涉及 TI 产品的相关应用。除此之外不得复制或展示所述资源，也不提供其它 TI 或任何第三方的知识产权授权许可。如因使用所述资源而产生任何索赔、赔偿、成本、损失及债务等，TI 对此概不负责，并且您须赔偿由此对 TI 及其代表造成的损害。

TI 所提供产品均受 TI 的销售条款 (<http://www.ti.com.cn/zh-cn/legal/termsofsale.html>) 以及 [ti.com.cn](http://www.ti.com.cn) 上或随附 TI 产品提供的其他可适用条款的约束。TI 提供所述资源并不扩展或以其他方式更改 TI 针对 TI 产品所发布的可适用的担保范围或担保免责声明。

邮寄地址：上海市浦东新区世纪大道 1568 号中建大厦 32 楼，邮政编码：200122

Copyright © 2020 德州仪器半导体技术（上海）有限公司