

设计指南: TIDA-010053

使用原电池的智能仪表无线模块低功耗选项参考设计



说明

此参考设计为使用锂二氧化锰 (LiMnO₂) 原电池的智能流量表提供了两种不同的电源架构, 以支持低于 1GHz、BLE、窄带物联网等各种无线技术。此设计主要侧重于适用于物联网 (IoT) 相关应用的现成商用窄带模块。这两种电源解决方案可与《[电池供电型智能流量表的电池和系统运行状况监控参考设计](#)》中的硬件结合使用, 以提供针对电池寿命的高精度运行状况 (SOH) 计算。常开系统内电流监控可检测射频传输的电流峰值, 并且在之后通过可调延迟安排 SOH 测量。

高效电源架构可为适用于物联网相关应用的窄带蜂窝模块供电, 具有 BQ35100 电池电量监测计, 能够提供实时电池寿命数据, 从而实现电池的及时更换。

资源

TIDA-010053	设计文件夹
TPS610995	产品文件夹
TPS62840	产品文件夹
CSD13385F5	产品文件夹
TIDA-01546	设计文件夹

特性

- 采用适用于智能仪表的超低功耗降压或升压转换器, 待机电流消耗低于 800nA
- 采用降压和升压转换器可分别提供 750mA 和 1A 峰值, 适用于低于 1GHz、BLE、窄带物联网等无线通信
- 基于单一评估板的电源解决方案, 支持各种电池结构和化学物质

应用

- 支持射频的应用包括:
 - 燃气表、水表、热量计、冷量计
 - 蜂窝式模块资产跟踪器件
 - 适用于物联网应用的资产跟踪传感器模块和标签
 - 故障指示灯 (FI)
 - 原电池供电型自动抄表 (AMR) 电子模块



咨询我们的 E2E™ 专家

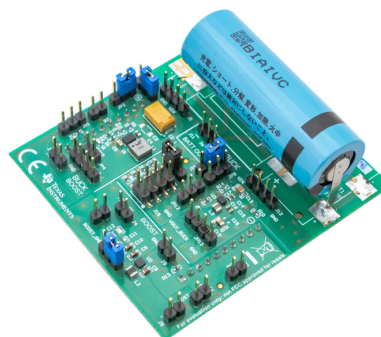
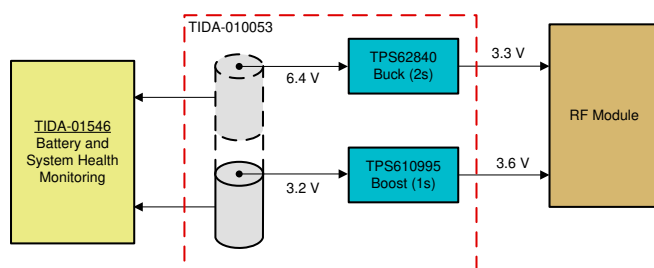

该 TI 参考设计末尾的重要声明表述了授权使用、知识产权问题和其他重要的免责声明和信息。

1 System Description

Smart utility meters with battery power, including gas, water and heat meters, represent a significant market opportunity for various wireless communication technologies such as: Sub-1 GHz, BLE, NB-IoT, and others. With these technologies come trade-offs that must be considered to select the appropriate protocol. For instance, Sub-1 GHz offers up to 1600 m of range at data rates maxing out a 500 kbps. These specifications are ideal for applications like metering, smoke detectors, or temperature sensors in buildings. However, when greater throughput is required, a higher frequency protocol may be more optimal, such as BLE, which can support ranges from 200 m to 400 m (LR) at 2.4 GHz, with a capped throughput of 2 Mbps. BLE is designed to support ultra-low power consumption, with the ability to survive off a coin cell for several years. Applications range from wireless keyboards to heart rate monitors, making it the most widely used wireless technology.

This design focuses mainly on NB-IoT which claims to ensure reliable connectivity deep inside buildings. NB-IoT boasts a range of 1 km in urban settings with a throughput peaking in the tens of kbps. Other NB-IoT promoted characteristics include low device unit cost, an improved outdoor and indoor penetration coverage compared with existing wide-area technologies, secure connectivity, and strong authentication as well as simplified network topology and deployment. The latter seems a major advantage versus all existing LPWA technologies, all of which require installation and maintenance of a proprietary RF network, comprising multiple data collectors, or data concentrator devices, or both.

Narrowband IoT (NB-IoT) is a 3rd Generation Partnership Project (3GPP) standards-based low-power wide area (LPWA) technology which uses licensed spectrum and can coexist alongside 3G and 4G cellular networks. NB-IoT deployment is underway in Europe and North America with multiple operators introducing services for smart devices such as vehicles, connected healthcare monitors, wearable devices, smart meters, asset tracking, and many others. NB-IoT is not equal to LTE CAT-M (also known as LTE-M) IoT technology used by some US mobile operators because NB-IoT is a separate network and not part of the operator's existing LTE network. The extensive availability of the sensor network paves the way for innovative and cost-effective NB-IoT solutions in virtually all business areas, including industrial transport and logistics, industrial automation, and the public sector.

The main advantage of 3GPP-standardized, cellular LPWA solutions is that they have the support of a huge existing ecosystem, and can therefore both be deployed and scaled up more rapidly, as well as having a single regulatory body that enforces the standard and controls interoperability across vendors and mobile operators. This LPWA standard is supported by 3GPP in [Release 13](#) and [Release 14](#) of their specifications.

Once a wireless technology has been selected, in this case NB-IoT, the power requirements must be investigated to choose an appropriate battery architecture. If a designer decides to use a single LiMnO₂ primary cell as their power source, then a boost configuration will be required to maintain, for example, 3.3 V from a battery that varies between 3.2 V down to 2.0 V across its lifetime. Alternatively, when two in-series cells are selected, a buck converter must be utilized. Using a buck will enable the two in-series cell voltage to be reduced to a value specified by a wireless module. The main trade-off between using a 1s or 2s configuration is cost and size versus battery lifetime. Both the 1s and 2s configurations are explored in this reference design.

1.1 Key System Specifications

表 1. Key System Specifications

PARAMETER	SPECIFICATIONS	DETAILS
Battery voltage: 3.2 or 6.4 V (1s or 2s configuration)	LiMnO ₂ primary battery cell (FDK CR17500EP)	2 节
Power consumption (load)	Electronic load or standard NB-IoT RF module	节 3.2.2.2
Average active-state current consumption (in RF transmit mode)	250 mA	节 3.2.2.2
Active-state duration	24 ms or 384 ms	节 3.2.2.2
I _q quiescent current	< 60 nA (TPS62840) or < 1 μA (TPS610995)	节 2.3.2
Stand-by state duration	29.616 s or 9.616 s (accelerated cell discharge test)	节 3.2.2.2
TX operations per hour	1 per 30 seconds or 1 per 10 seconds (accelerated cell discharge test)	节 3.2.2.2
Estimated energy consumption	2053 mAh at 384 ms transmit pulse (no conversion losses and 100% battery lifetime at 20–30°C)	节 3.2.2
Measured battery lifetime	> 15 years (4 RF transmit cycles per day at 20–30°C)	节 3.2.2

2 System Overview

Primary LiMnO₂ batteries are becoming more and more popular in many IoT-enabled applications, due to their capability of providing high-current pulses up to 4000-mA peak (see the [FDK CR17500EP Data Sheet](#)) without suffering any performance degradation and without the need of external Hybrid-Layer Capacitors (HLC) or Super-Pulse Capacitors (SPC), which are required for LiSoCl₂ primary cells. LiMnO₂ batteries are viewed as less toxic, and do not lose capacity if mounted in a non-optimal position inside the end product.

The main disadvantage of LiMnO₂ cells is the lower cell voltage, starting at about 3.2 V for new batteries at 23°C and going down to 2.0 V; the latter being the common value for a cutoff voltage (or end of-life).

Many common NB-IoT cellular modules, like U-blox SARA-N211 or Quectel BC95-B8 require a minimum supply voltage of 3.1 V or higher for proper operation. Thus, a voltage boost functionality becomes mandatory if a single cell LiMnO₂ cell is used, which is typical for many residential-type meters, such as for gas, water, and heat or cold.

In many applications, two cells in-series may be preferred; here, a buck topology to down-convert the input voltage is suitable.

2.1 Block Diagram

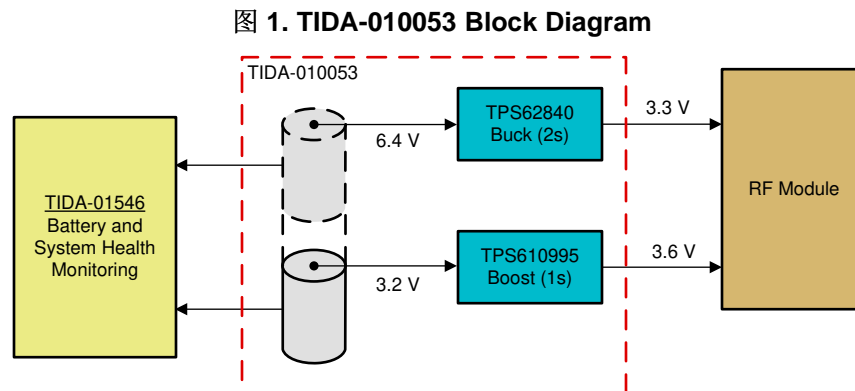

2.2 Design Considerations

For easier comparison of the various power architectures under identical test conditions, the TIDA-010053 reference design combines the TPS62840 (buck converter) and the TPS610995 (boost converter) onto a single PCB. The load can be either an NB-IoT module connected to the cellular network, or an electronic load which simulates the load profile. The boost device supports a single LiMnO₂ primary cell configuration while the buck device enables use cases with two in-series primary cells. The PCB enables testing of these two devices under the same application conditions to find the best technical solution for each customer use case.

There are multiple constraints in smart metering applications, which will influence the selection of the power architecture. Smart water, heat or cold meters as well as add-on RF-enabled modules for mechanical flow meters typically are size-constrained physically (see standards documents EN1434 for water and EN4064 for heat meters). Most of these meters operate from a single primary cell, for example electronic add-on modules with RF functionality with 1–2 Ah capacity achieve a lifetime of at least 5-6 years, if using the wM-Bus RF protocol (EN13757) T- or C-mode for data communication in the 868-MHz Industrial, Scientific, Medical (ISM) *unlicensed* frequency band.

The new NB-IoT communication modules do offer similar mechanical size and PCB footprint as existing Sub-1 GHz RF solutions but deliver longer range coverage at the cost of higher average power consumption while using higher transmit power in the *licensed mobile network* frequency bands.

As mobile networks are controlled by the mobile operators, including the power saving features which heavily influence the power consumption of the NB-IoT module, it is close to [impossible to predict the battery lifetime of an NB-IoT module](#) inside a smart meter or any other IoT product.

This reference design proposes a solution for this challenge by measuring the battery drain with a dedicated device such as the BQ35100 as implemented in the [TIDA-01546](#) design. Integrating the BQ35100 battery-gauge device allows for in-system precise measurement of the State-of-Health (SOH) for the LiMnO₂ cells and wirelessly reporting the SOH value over the NB-IoT network. Updating the SOH status by the BQ35100 device takes approximately one second and can be done very infrequently, for example starting with a fresh primary cell just once after several weeks or even months to save energy. The subsequent SOH update period can be continuously adjusted based on an algorithm which considers the expected battery drain and correlating that to the measured SOH data, see [节 3.2.2.2](#).

To obtain the highest SOH accuracy, TI recommends measuring the battery with the BQ35100 device only after a sufficient relaxation time after the high-current pulse for RF transmission occurred. For example, the BQ35100 gauge device is enabled 10 minutes after the last current pulse used for NB-IoT data transmission but the 10 minute delay period can be programmed to any suitable value. The ADS7142 system health monitor in the [TIDA-01546](#) design is used to detect the high-current pulse and the application waits for the appropriate battery relaxation time, before running an SOH measurement.

2.3 Highlighted Products

The TIDA-010053 design includes two state-of-the-art power switching controller devices on a single PCB, with the boost device supporting boosting the voltage of a single LiMnO₂ primary cell up to 3.6 V. The ultra-low I_Q current buck device enables the usage of two primary cells, in-series and regulates the output voltage to 3.3 V.

2.3.1 TPS610995: 0.7 V_{IN} Synchronous Boost Converter With 800-nA Ultra-low Quiescent Current and 1-A Peak Current

The TPS610995 device is a synchronous boost converter with 1- μ A ultra-low quiescent current. The device is designed for products powered by an alkaline battery, nickel metal hydride (NiMH) rechargeable battery, LiMnO₂ battery or rechargeable lithium-ion (Li-Ion) battery, for which high efficiency under light load conditions is critical to achieve long battery life.

The TPS610995 boost converter uses a hysteretic control topology to obtain maximal efficiency at minimal quiescent current. It only consumes 1- μ A quiescent current under light load conditions and can achieve up to 75% efficiency at 10- μ A load with fixed output voltage version. It can also support up to 300-mA output current from 3.3-V to 5-V conversion, and achieve up to 93% at 200-mA load.

图 2. TPS610995 Functional Block Diagram

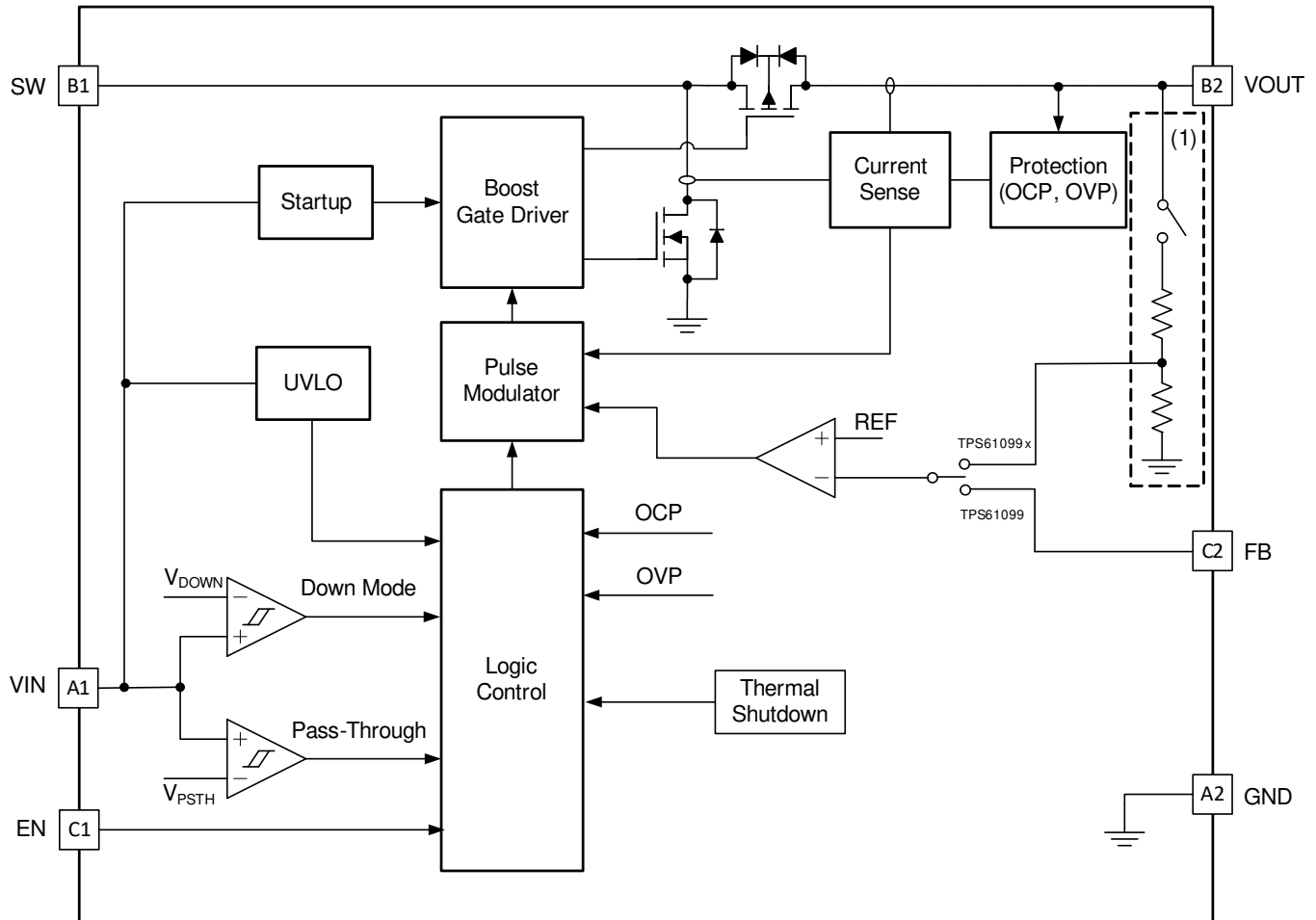

The TPS610995 also offers both down mode and pass-through operations for different applications. In down mode, the output voltage can still be regulated at target value even when the input voltage is higher than output voltage. In pass-through mode, the output voltage follows the input voltage. The TPS610995 exits down mode and enters into pass-through mode when $V_{IN} > V_{OUT} + 0.5 \text{ V}$.

The TPS61099 family of devices supports true shutdown function when it is disabled, which disconnects the load from the input supply to reduce the current consumption. There are both adjustable output voltage version and fixed output voltage device versions, such as the TPS610995 device which is used in this reference design. It is available in 6-ball, 1.23-mm x 0.88-mm WCSP package and 6-pin 2-mm x 2-mm WSON package.

2.3.2 TPS62840: 750-mA Synchronous Step-Down Converter With Ultra-low Quiescent Current Consumption

The TPS62840 device is a synchronous step-down converter with ultra-low quiescent current consumption. Using TI's DCS-Control™ topology the device extends the high efficiency operation area down to micro amperes of load current during *Power-Save Mode Operation*.

TI's DCS-Control (Direct Control with Seamless Transition into Power-Save Mode) is an advanced regulation topology, which combines the advantages of hysteretic and voltage mode controls. Characteristics of DCSControl include excellent AC load regulation and transient response, low output ripple voltage, and a seamless transition between PFM and PWM mode operation. DCS-Control includes an AC loop which senses the output voltage (VOS pin) and directly feeds this information into a fast comparator stage.

The device operates with a quasi-fixed frequency of 1.8 MHz (typ). A high gain voltage feedback loop is used to achieve accurate DC load regulation. To save extra quiescent current under light-load condition (that is, IO_{UT} in the mA range), the internal error amplifier is powered down with a minimum influence on the DC line and load regulation characteristic. The internally compensated regulation network achieves fast and stable operation with small external components and low ESR capacitors.

In *Power-Save Mode*, the switching frequency varies linearly with the load current. Since DCS-Control supports both operating modes with one single building block, the transition from PWM to PFM is seamless with minimum output voltage ripple. The TPS62840 device offers both excellent DC voltage and superior load transient regulation, combined with low-output voltage ripple thereby minimizing interferences with RF circuits.

图 3. TPS62840 Functional Block Diagram

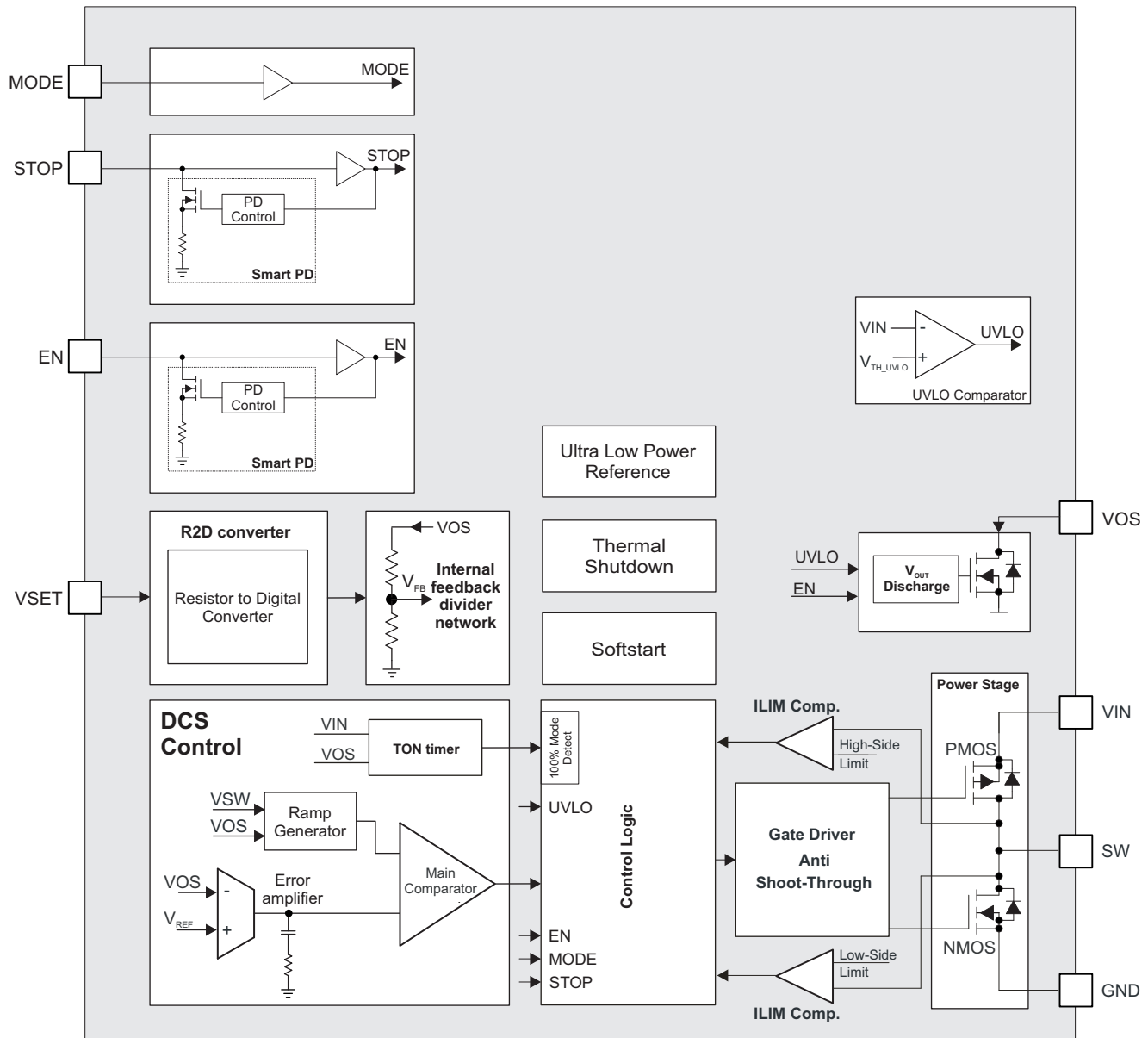

At light load conditions it seamlessly enters power save mode to reduce switching cycles and maintain high efficiency. There are 16 predefined output voltages that can be selected by connecting a resistor to the VSEL pin making the device flexible for various applications with a minimum amount of external components.

2.4 System Design Theory

Predictive maintenance of smart meters is one of the main topics which is addressed in the [TIDA-01546](#) design, and it is becoming more relevant for many other IoT applications, such as battery-powered sensor nodes.

The [TIDA-01546](#) reference design is designed to accurately monitor the battery health of non-rechargeable lithium batteries and detect any overcurrent conditions in the system. The TM4C1294 MCU is programmed to control the BQ35100 gauge monitor and the ADS7142 sensor monitor. A microSD™ card inserted into the SD card slot can record the battery-monitoring data.

The system health monitoring section of the [TIDA-01546](#) reference design monitors user definable overcurrent conditions during run time and is implemented with the ADS7142 current monitor and LPV521 operational amplifier. The host MCU (TM4C1294) communicates through the I2C interface with the ADS7142 device, which has a digital window comparator with a dedicated ALERT output pin for interrupting the host when the software-programmable high or low threshold is crossed.

2.4.1 Battery Gauge BQ35100

For details on how the BQ35100 device operates, see the [Battery and System Health Monitoring of Battery-Powered Smart Flow Meters Reference Design Guide](#) of the [TIDA-01546](#). For the tests with electronic load and NB-IoT modules, a special reference file (also called ChemID) for the FDK CR17500EP battery is generated by TI, which allows accurate SOH measurement of this battery.

Only one of the two power devices in the [TIDA-010053](#) is powering the NB-IoT module (or electronic load to start with) from the FDK battery at a given time, as described in [节 3.1.4](#).

2.4.2 In-System Current Monitoring

The second relevant subsystem of the [TIDA-01546](#) reference design uses the ADS7142 nanopower SAR ADC device, which can measure both a *low-current range* with 0–10 μA and a *high-current range* with 0–476 mA current. The range selection is deliberately made, as typically in ultra-low power metrology mode a smart flow meter device uses less than 10 μA average current. The second range for up to 476 mA is used when the smart meter or IoT application is running an NB-IoT communication (or any other wireless communication with the corresponding current profile, for example [wM-Bus N-mode transmission in 169 MHz band](#) with up to +25 dBm). These two current profile ranges align quite well with the data sheet values for power-saving mode and active mode for both NB-IoT modules described in [节 2.4.3](#) and in [节 2.4.4](#).

2.4.2.1 Resistor Values Calculation for the two Current Ranges

The following explains how designers can customize the two current ranges to support many other battery-powered IoT applications in only two steps:

- Changing (if necessary) the values of R32 and R33 in the [TIDA-01546](#) system monitoring subsystem schematics (see [图 4](#))
- Software modifications for the high- and low-threshold registers of the ADS7142 device

The default resistor values for R32 = 6.8 k Ω and R33 = 0.1 Ω define the ranges 0–10 μA and 0–476 mA and achieve sufficient accuracy and resolution in each of these ranges. Select the resistors based on the load profile of the application. Note that in many cases, there are more than two current ranges for the load profile, so some simplification for this selection by the designer is needed.

Splitting the two ranges enables accurate measurement of both very low currents down to 300 nA (see the [Battery and System Health Monitoring of Battery-Powered Smart Flow Meters Reference Design Guide](#)) but also six orders of magnitude higher currents of up to 476 mA.

Only R32 = 6800 Ω is used when the system has settled after a possible load profile transition and operates in the 0–10 μA range, which is usually the case for the majority of the run time for many smart flow meters.

The system monitoring with the ADS7142 device is done by continuously comparing the current drawn by the application to the high and low thresholds and by raising an alarm through the ALERT pin to the TM4C Host MCU, if one of those is crossed.

图 4. Dual Shunt for System Health Monitoring Subsystem in TIDA-01546

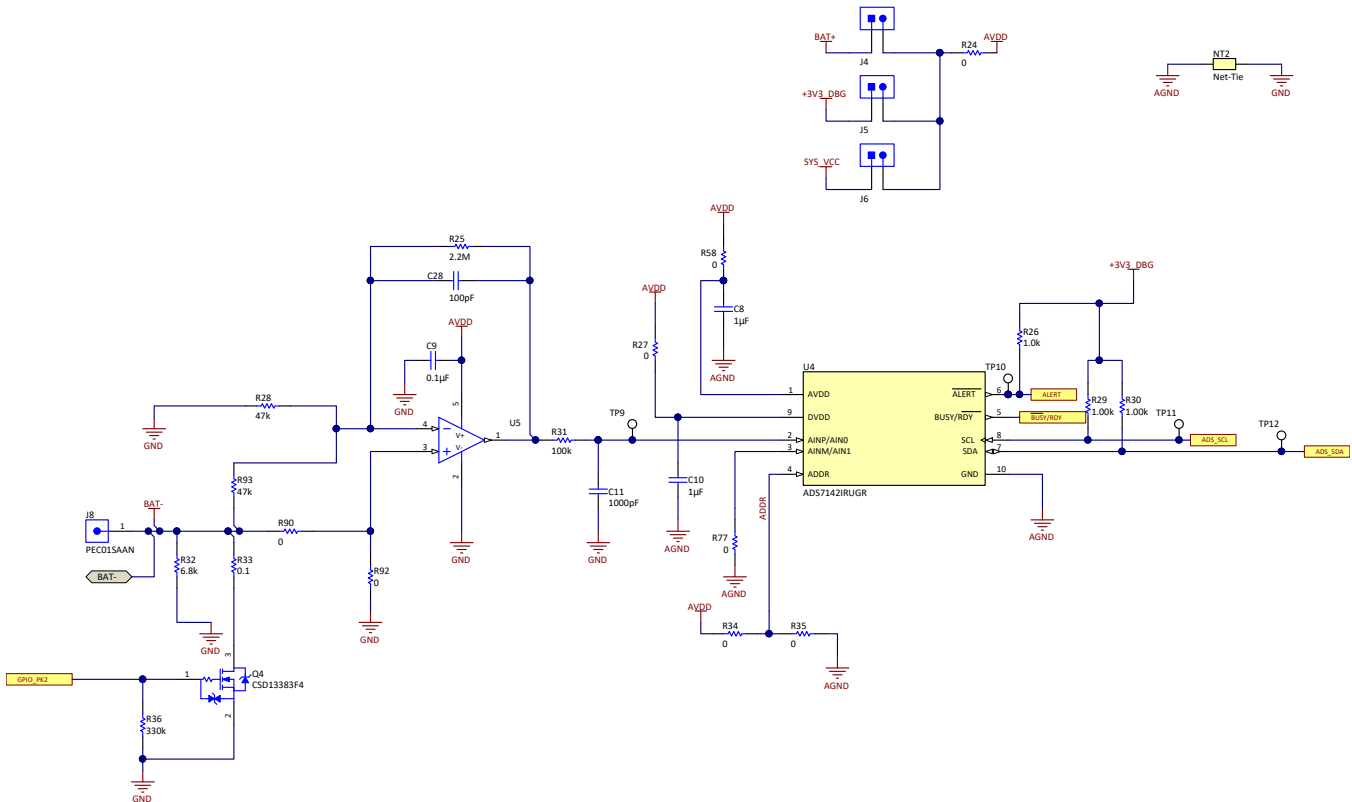

When the current rises above the programmed high-threshold level, the ALERT high event is triggered and the TM4C MCU gets an interrupt. Only if the system is already operating in the low-current range, the host switches on the CSD13383F4 FemtoFET™ device, which enables the current flow through R33. Thus, the overall resistance is now R32 || (R33 + the CSD R_{DS(on)}), where R_{DS(on)} is assumed to be 45 mΩ at 3.3 V, based on the existing data sheet values.

$$R = \frac{R32 \times (R33 + R_{DS(on)})}{R32 + R33 + R_{DS(on)}}$$

or

$$R = \frac{6800 \times (0.1 + 0.045)}{(6800 + 0.1 + 0.045)} = 0.145 \Omega \tag{1}$$

The high threshold ALERT is re-triggered at the next data conversion, if the PRE_ALT_MAX_EVENT_COUNT is set to 0, but the TIDA-01546 firmware for the host MCU ignores it, if the device is already in the high-current range.

Vice versa, when the current drops back to low-current range, the ALERT pin is set by the low threshold and the MCU reads out which threshold set the alarm and switches the FemtoFET device off, which puts the system back to the initial condition.

2.4.2.2 LPV521 Gain Calculation

The resistors R25 and R28 in the TIDA-01546 reference design are used to set the gain value of the LPV521 device:

$$G = \frac{R28 + R25}{R28} = \frac{47 \text{ k}\Omega + 2200 \text{ k}\Omega}{47 \text{ k}\Omega} = \frac{2247}{47} = 47.81 \quad (2)$$

The AVDD voltage of the ADS7142 device defines the full-scale input range of the device and for the [TIDA-01546](#) design, it is set to 3.3 V and is the maximum input voltage. With this, and knowing the gain G , calculate the maximum V_{IN} value for the input voltage of the LPV521 device:

$$\text{MAX } V_{IN} = \frac{\text{MAX } V_{OUT}}{G} = \frac{\text{MAX } V_{\text{input to ADS7142}}}{G} = \frac{3.3 \text{ V}}{47.81} = 69 \text{ mV} \quad (3)$$

The 69 mV represents the full-scale voltage which can be applied to the input of the LPV521 device regardless of the current range used.

For these two current ranges, the maximum current value is one of the following:

1. $69 \text{ mV} / R32 = 6800 \text{ }\Omega =$
2. **10.47 μA** for the **low-current range**
3. $69 \text{ mV} / 0.145 \text{ }\Omega =$ **475.86 mA** for the **high-current range**

The minimal current values are enumerated in the following, since there are 4096 ADC steps:

1. $10.47 \text{ }\mu\text{A} / 4096 = 2.55 \text{ nA}$
2. $475.86 \text{ mA} / 4096 = 116 \text{ }\mu\text{A}$

The LPV521 and ADS7142 devices monitor the system current continuously with a minimum power consumption, since both devices draw about 1 μA when running from a 3.3-V supply.

2.4.2.3 Current Ranges Simulation With TINA-TI

[图 5](#) shows the TINA-TI simulation results with the current flowing through the 0.1- Ω resistance. When injecting a 493-mA current into the system, the input voltage of operational amplifier is 69.03 mV (slightly above the calculated 69 mV). The resulting output voltage is 3.29 V, which is close to the calculations in [节 2.4.2.2](#) and the 3.3 V full-scale voltage.

图 5. TINA-TI Simulation for the High-Current Range Using 0.1-Ω Resistor Value



图 6 shows the simulation of the current flowing through the 6.8-kΩ resistor. With 10-μA current into the system, the input voltage of the LPV521 device is 67.99 mV (a bit below the 69 mV maximum value).

图 6. TINA-TI Simulation for the Low-Current Range Using 6.8-kΩ Resistor Value

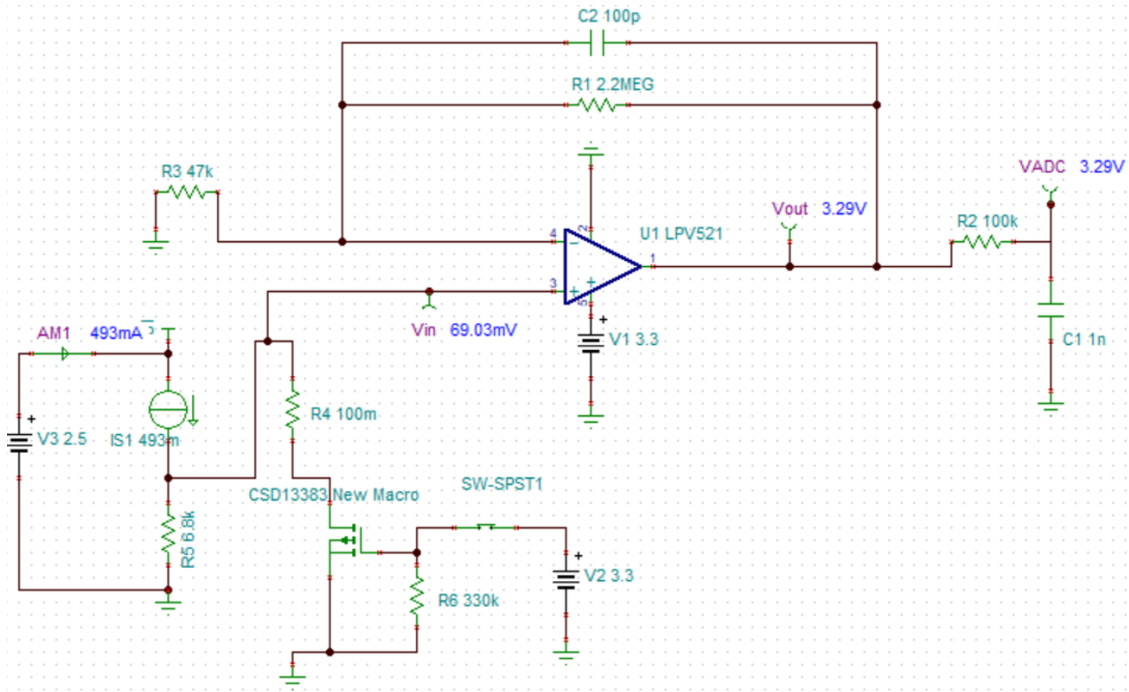
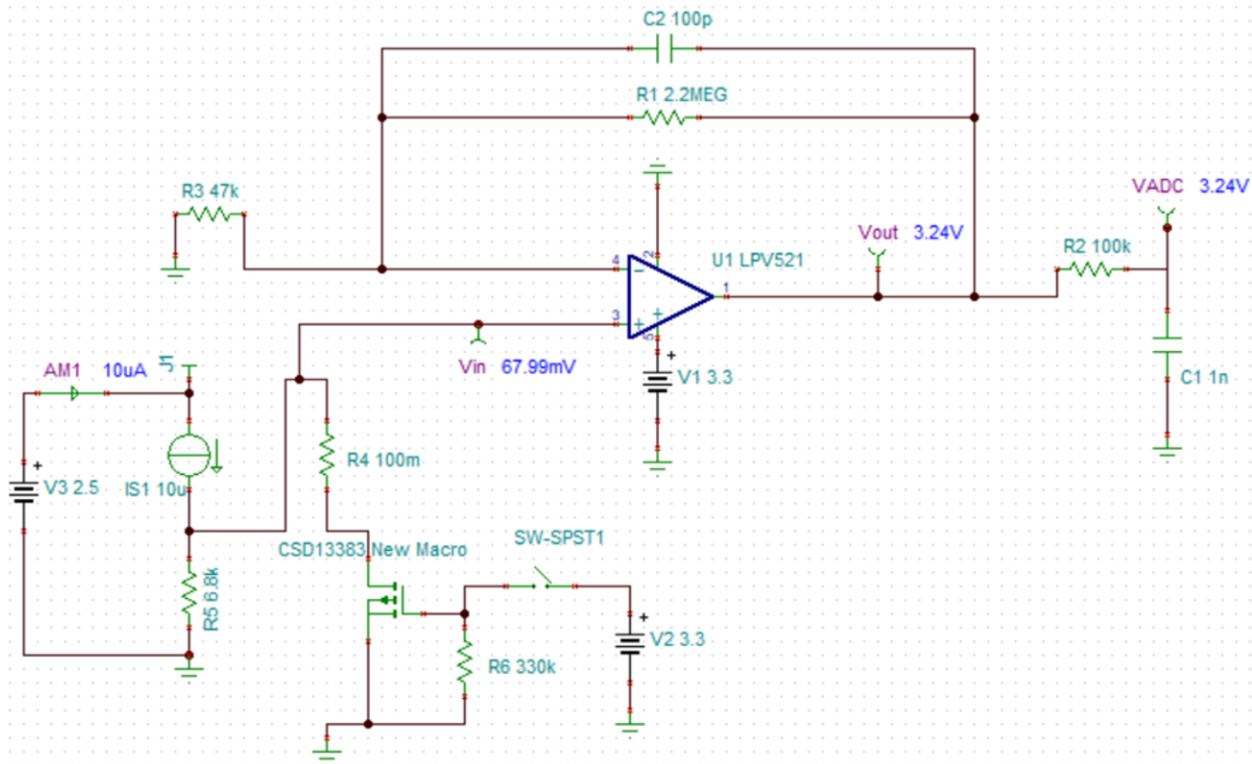

The simulated output voltage is 3.24 V, also slightly below the maximum allowed voltage of 3.3 V, which is in line with the calculated results.

Using the TINA-TI simulation file included with this reference design, designers can calculate the resistor values required for their application.

2.4.2.4 Key ADS7142 Register Settings in TIDA-01546 Firmware

The [TIDA-01546 software](#) implements the logic for the system monitoring and battery gauge functions under the assumption that the load profile is a square wave. This square wave alternates between above the window comparator high and below the window comparator low thresholds of the ADS7142, both of which are user programmable.

There is only one set of high- and low-threshold registers in the ADS7142 device, which means that the user-defined threshold values represent different current values, depending on which current range (or resistor) is active. In other words, the ADS7142 threshold settings are used to detect the rising and falling edges of the load profile and respectively switch the 0.1-Ω resistor on and off.

Using the 10.47 μA and 475.86 mA from the [list](#) in [节 2.4.2.2](#), calculate and program the threshold current values as appropriate. The conversion output by the ADS7142 device at 3.3 V is equal to 0xFFFF (this is a 12-bit SAR ADC). The default firmware settings for the high- and low-threshold are 0x998 and 0x028 respectively, and correspond to the following:

1. $0x998/0xFFFF = 2456/4096 = 0.5996 = \mathbf{0.6}$ for the **low-current range**
2. $0x028/0xFFFF = 40/4096 = 0.00976 = \mathbf{0.01}$ for the **high-current range**

表 2 shows the conversion of these threshold values into a current value.

表 2. Threshold Settings in Firmware for the two Current Ranges

LOAD PROFILE	THRESHOLD (ADS REGISTER VALUE)	THRESHOLD CURRENT (A)	SHUNT RESISTANCE (Ω) IN USE
Low to High transition	HTRH = 0x998	$0.6 \times 10.47 \mu\text{A} = 6.28 \mu\text{A}$	6800
High to Low transition	LTHR = 0x028	$0.01 \times 476 \text{ mA} = 4.76 \text{ mA}$	0.1 + 0.045

The stand-by current of the board must be below 6.28 μA , and the active current must stay above 4.76 mA up to 476 mA; otherwise, the 0.1- Ω resistor switches on and off unnecessarily. Modify these settings by changing the values in the high- and low-threshold registers of the ADS7142 device.

注: Due to the asymmetric threshold current values when switching from the low-current to the high-current range and back, carefully select the high and low thresholds (including the optional ADS7142 window comparator hysteresis settings) to avoid erroneous changes from one current range to the other.

2.4.2.4.1 ADS7142 Sampling Rate

For the lowest possible power consumption, the ADS7142 nanopower sensor monitor is programmed to run from the low-power oscillator with nCLK = 18, which is the minimum recommended value setting in the nCLK_SEL register. According to the [ADS7142 Nanopower, Dual-Channel, Programmable Sensor Monitor Data Sheet](#), this results in a conversion time in the range of $18 \times 95.2 \mu\text{s}$ or $18 \times 300 \mu\text{s}$, or approximately 1.7 to 5.4 ms. Thus, the lowest sampling rate is *not* a fixed value, which must be considered when evaluating the load profile and the firmware timings for data read out in the application.

The *Post Alert* data mode is one of the *Autonomous* modes and is selected by the OPMODE_SEL register setting 0x110b. This directs the device to capture the next sixteen conversion results after the *Alert* has become active. Once these sixteen conversions are stored in the internal data buffer, all conversion stops and the host MCU can read out the values.

2.4.3 NB-IoT Module From u-blox

The SARA-N211 is a power-optimized NB-IoT (LTE Cat NB1) module by [u-blox](#) and is certified to operate in multiple mobile networks around the world, including the one from Deutsche Telekom.

The operating temperature is -40°C to $+85^{\circ}\text{C}$ and the supply voltage range is between 3.1 and 4.0 V (normal). Deep-sleep mode is 3 μA (averaged over 10 s), while in transmit mode 220 mA at + 23-dBm TX power are drawn.

2.4.4 NB-IoT Module From Quectel

The BC95-B8 NB-IoT module is a compact NB-IoT Module with ultra-low power consumption which is certified for multiple networks, including the one from Deutsche Telekom. The module has an operating temperature of -40°C to $+85^{\circ}\text{C}$ and the supply voltage range should be between 3.1 and 4.2 V (3.6 V typical).

Deep-sleep mode is 3.6 μA at PSM and the current drawn is 220 mA at + 23-dBm transmit power (when operating in frequency bands B8, B5, and B20).

3 Hardware, Software, Testing Requirements, and Test Results

3.1 Required Hardware

The TIDA-010053 reference design is tested at the bench for efficiency and load response.

3.1.1 Testing TIDA-010053

The two different power solutions were tested separately of each other to confirm that the design performs according to the data sheet values.

3.1.2 TPS62840 Subsystem

The transient load response with the TPS62840 buck device on the TIDA-10053 reference design was tested under these conditions:

- $V_{IN} = 5.0\text{ V}$; $V_{OUT} = 3.3\text{ V}$
- $I_{o_min} = 0\text{ A}$; $I_{o_max} = 250\text{ mA}$
- Period = 2s; duty cycle = 50%
- SR = 0.8 A/ns

The zero A are simulating the typically $< 5\ \mu\text{A}$ in deep-sleep mode, while the 250 mA are derived from 220 mA (typical current at +23-dBm TX power level for the u-blox and Quectel NB IoT Modules) +25-mA margin in case of maximum current + 5 mA for the rest of the application (Host MCU + Metrology + all other subsystems of a smart meter).

The transient load test result for the 2-second pulse (3.3 V_{out} is set) is shown in 图 7, with the output voltage being regulated between $V_{o_min} = 3.2987\text{ V}$ and $V_{o_max} = 3.3373\text{ V}$.

图 7. TPS62840 Transient Load Response for 0- to 250-mA Step

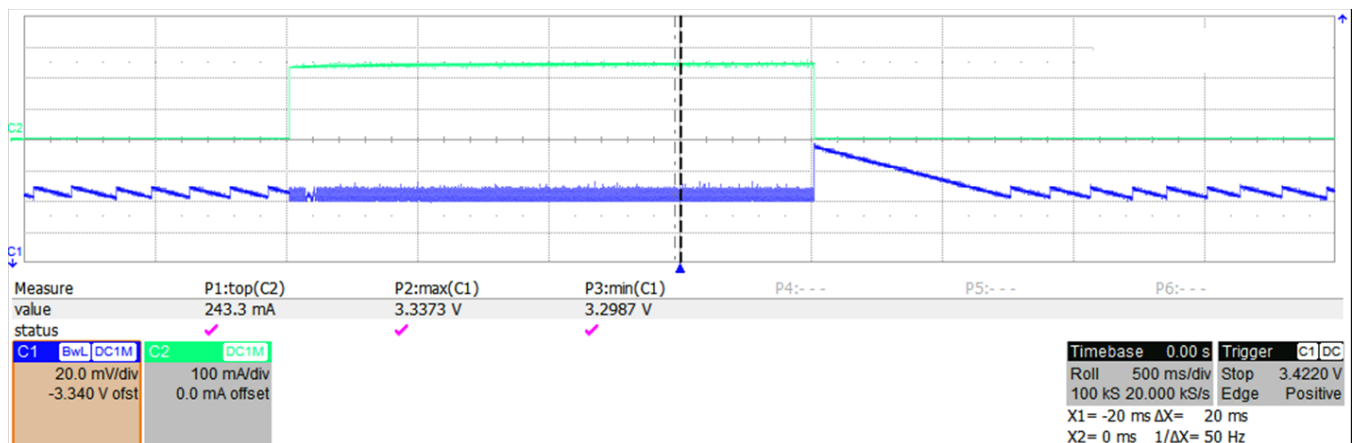

The efficiency is confirmed by having the device operating at PWM mode with switching frequency $F_{sw} =$ approximately 1.8 MHz.

P_{IN}	P_{output}	EFFICIENCY (%)
4.950 V × 0.522 A = 2.58 W	3.301 V × 0.7094 A = 2.34 W	90.63

3.1.3 TPS610995 Subsystem

Bench tests were run to measure the transient load response with the TPS610995 with fixed $V_{OUT} = 3.6\text{ V}$ on TIDA-10053. For this, the following test conditions apply:

- $V_{IN} = 1.8 - 3.2\text{ V}$
- Fixed $V_{OUT} = 3.6\text{ V}$; $I_{O_max} = 500\text{ mA}$

The following efficiency table shows the results for $I_{OUT} = 250\text{ mA}$ with $V_{IN} = 2.5\text{ V}$, which is the average value for LiMnO2 cells over their lifetime.

$V_{IN} = 2.5\text{ V}$	$V_{OUT} = 3.6\text{ V}$	EFFICIENCY (%) at 250 mA
393.7 mA	251 mA	91.81

图 8 shows the full efficiency plot over the load current I_{out} .

图 8. Efficiency Plot vs Load Current



图 9 shows a load transient plot for I_{OUT} from 50 mA to 200 mA.

图 9. TPS610995 Load Transient Response

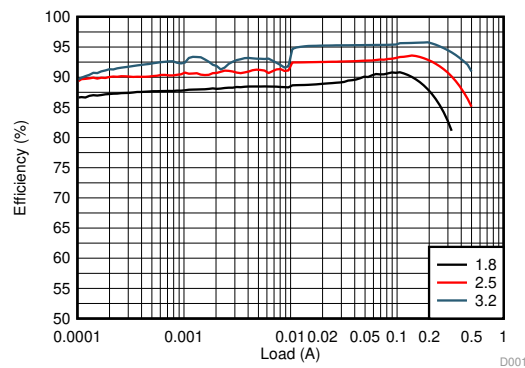

图 10 shows the ripple for $V_{OUT} = 3.6\text{ V}$ and $V_{IN} = 3.2\text{ V}$.

图 10. TPS610995 $V_{OUT} = 3.6\text{ V}$ With $I_{OUT} = 200\text{ mA}$

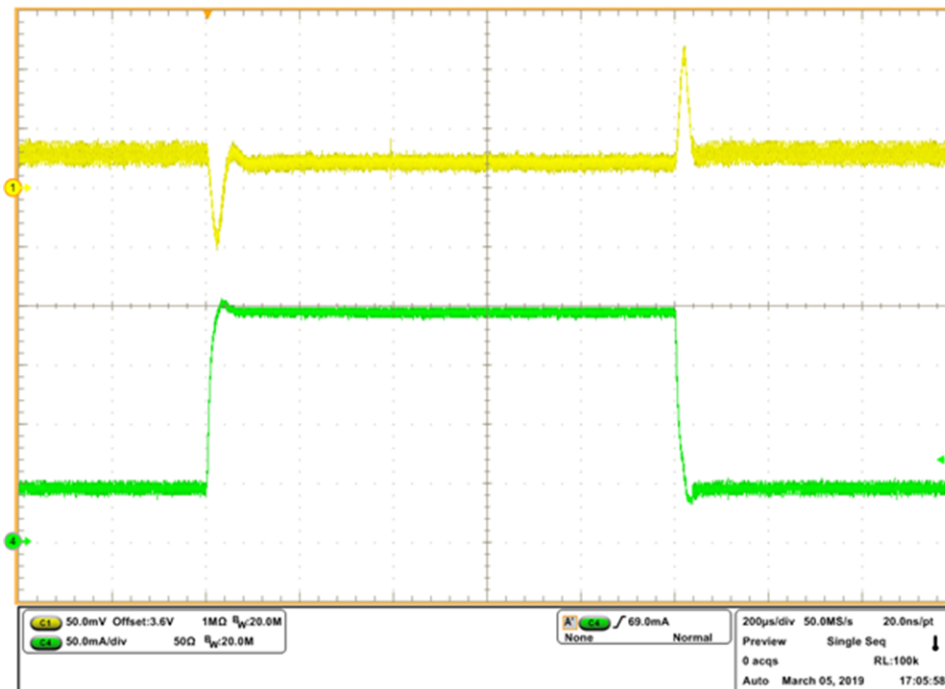
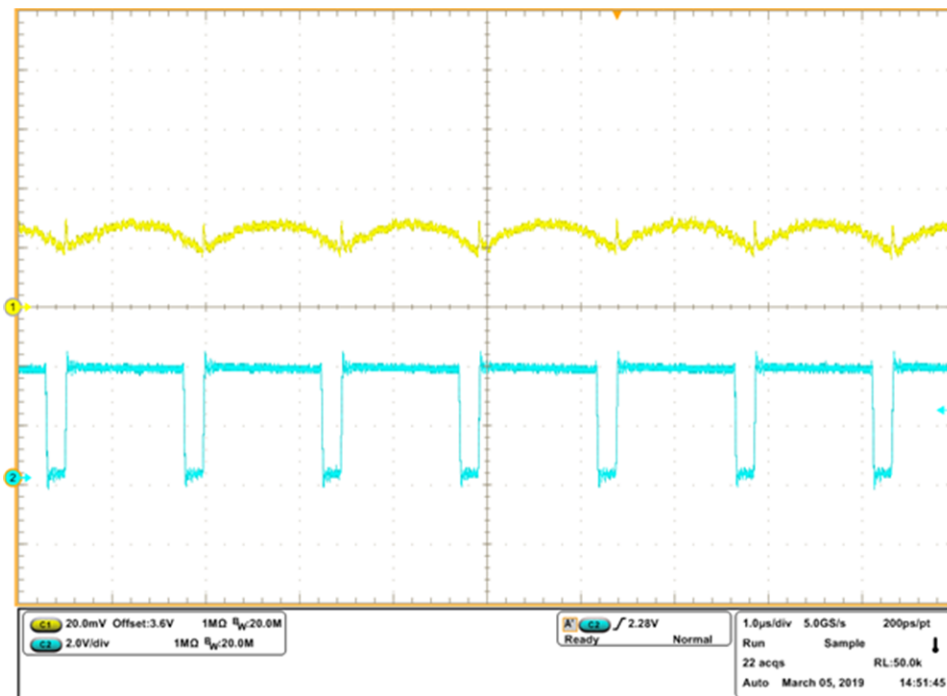

3.1.4 Software

Both TIDA-010053 and [TIDA-01546](#) designs can be combined to enable both periodic SOH measurements and the continuous *System Health Monitoring*. The updated [TIDA-01546 software](#) is programmed into the T4MC MCU, as explained in the *Reprogram TIDA-01546* section of the [Battery and System Health Monitoring of Battery-Powered Smart Flow Meters Reference Design Guide](#).

This software supports logging data onto a microSD card and a UART communication port is added to the source code of the TM4C host MCU. Thus, sending out log data to a COM port of a PC, running a terminal program such as HTerm, is possible.

The software for the TIDA-01546 design is updated to the latest Tiva_C MCU library, named [TivaWare_C_Series-2.1.4.178](#) as well as [CCS version 9.0.1](#) (latest as of June 2019).

3.2 Testing and Results

The discharge of the primary cell configurations were estimated as well as measured on the bench for both power converters used in the TIDA-010053 reference design.

3.2.1 Test Setup

Two in-series or one individual FDK battery, determined by the buck or boost configuration, (see the [FDK CR17500EP Data Sheet](#)) were soldered to the TIDA-010053 design and wired as in [图 11](#) to the [TIDA-01546](#) battery monitoring system. Then, using the *BQ Studio GUI* software, the BQ35100 primary cell battery gauge was configured and calibrated.

图 11. Setup With Battery, TIDA-010053, and TIDA-01546

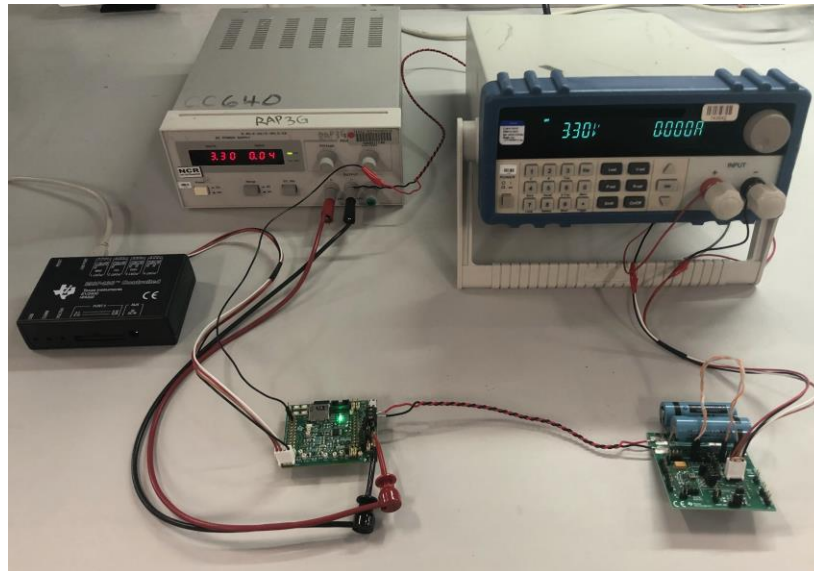

This shows the lab set up for the two-cell buck configuration. The single-cell boost configuration is nearly identical with the exception of battery count and header placements.

图 12 shows the lab bench device configuration.

图 12. Test Setup Block Diagram

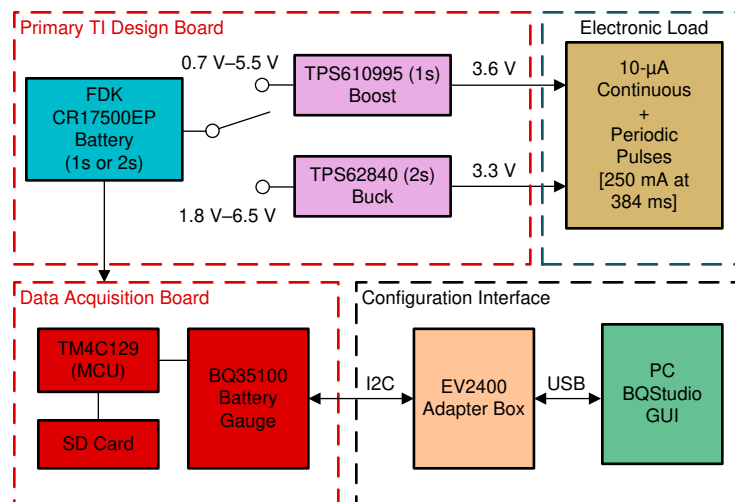

To emulate the battery discharge profile of an NB-IoT module RF transmission and also speed-up the testing, the following electronic load profile was chosen:

- Transmit RF: 250 mA for 384 ms (1 pulse x 30 s or 1 pulse x 10 s)
- Metrology mode: 10-µA continuous base load

In addition to the electronic load for transmission emulation, metrology mode was represented through load resistors, which were connected to V_{OUT} of both the TPS62840 buck converter and TPS610995 boost converter devices. The TPS device currents, I_{OUT} , were measured to be 10 µA, representing the 5- to 6-µA average current drawn in stand-by in many applications plus the 4 µA for power-save mode for the NB-IoT modules, see 节 2.4.3.

Using [TIDA-01546](#), the onboard BQ35100 device was configured through the J18 I2C connector, then programmed using an [EV2400](#) and a PC with *BQ Studio GUI* software installed. The ChemID = 0x635 was loaded to the device for the FDK CR17500EP cells and either the 2s or 1s cell configuration was selected. Additionally, jumpers J1 and J2 were set to the 2s or 1s configuration on the [TIDA-01546](#) board, depending on the device under test. The ambient temperature of 21°C and the voltage offset were calibrated using a digital thermometer and digital multimeter, as reference. Furthermore, all devices used – besides the buck and boost converter – were powered through an external 3.3-V power supply. This was done to isolate the power consumption of the NB-IoT electronic load profile and the power converters.

The MCU on the [TIDA-01546](#) was programmed to trigger an electronic load via GPIO, pulsing 250 mA for 384 ms. SOH and voltage data points were captured just prior to the next electronic load pulse, to ensure the voltage and SOH were most accurately reflected and maximizing available battery relaxation time. Additionally, the MCU issued a new battery command every cycle, such that the SOH captured was allowed to increase over time. This was done to capture raw data each cycle; however, in practice the new battery command would only be issued at the beginning of testing, preventing the SOH reading from increasing. This automated battery discharge and data collection set up ran throughout the entire lifetime of the primary cells.

3.2.2 Test Results

3.2.2.1 Battery Lifetime Estimation

Lifetime calculation was provided by the battery vendor for the following application profile:

Transmit RF: 250 mA for 384 ms (4 data packets per day)

Active mode: 4 mA for 3.8 seconds (1 per day)

Stand-by mode: 10 µA continuous base load

注: The *active mode* consumption of 4 mA for a few seconds daily is added in addition to the test profile at the bench to reflect common requirements for various applications.

As the battery temperature profile plays a significant role in the lifetime calculation, it must be considered. This is done by defining the percentage of time spent in specific temperature range steps for every 10°C by applying a battery vendor-specific factor. For simplification and easier comparison of the test bench results which were done at 25°C, the estimation assumes that 100% of the battery lifetime is spent in the range of 20–30°C.

The calculation is a simple addition of the power consumed in each mode without considering any power conversion losses, see [公式 4](#) for the power in one calendar year (or 365 days). The total ideal power consumption for 15 years amounts to 1934 mAh or **2127.4 mAh** when assuming a 90% average conversion efficiency across all modes (transmit, active, and stand-by).

Overall, 2127.4 mAh amount of energy is consumed for **21,900** transmit cycles of 384 ms duration and 250 mA current. Thus, 3000-mAh capacity can support **30,883** transmit cycles if the battery spends its complete lifetime at 20–30°C.

$$4 \text{ mA} \times \frac{3.8}{3600} \times 365 \text{ days} = 1.541 \text{ mAh} \quad (4)$$

$$250 \text{ mA} \times \frac{0.384}{3600} \times 4 \times 365 \text{ days} = 38.933 \text{ mAh} \quad (5)$$

$$10.1 \mu\text{A} \times 24 \text{ h} \times 365 \text{ days} = 88.5 \text{ mAh}$$

(6)

3.2.2.2 Test Results With the TPS62840 Buck Converter

图 13. TPS62840 Buck Battery Discharge Data (2s Configuration)



图 13 shows that the cells can withstand over **140,000** transmissions, using the **TPS62840** buck converter to power NB-IoT modules. It is important to acknowledge that this test was conducted over a short period of time, where in the field, stand-by current will play a factor in addition to the 250-mA pulses, accounting for the several years of field life. Considering the findings from 节 3.2.2.1 and the data collected on the bench, the total transmission number for a field application can be approximated to be between **61,766** and **140,000**, if the battery spends its complete lifetime between 20–30°C.

Since the LiMnO₂ battery chemistry very strongly maintains its voltage, partially increasing for the first half of its lifetime, the gauge will return a more coarse measurement surrounding SOH. However, around the midpoint at 70,000 transmissions, SOH approaches 50% and eventually drops to 0% consistently. See the FDK CR17500EP LiMnO₂ primary battery [data sheet](#) to observe typical voltage discharge curves.

It is important to note the market leading light-load efficiency of the **TPS62840** buck converter at 10 μA (the stand-by current in this test) (see *Efficiency vs. Load Current* plot in the [TPS62840 1.8-V to 6.5-V, 750-mA, 60-nA \$I_Q\$ Step-Down Converter Data Sheet](#)). The efficiency is in the range of 82–88% for $V_{\text{IN}} = 6.5 \text{ V}$ to $V_{\text{IN}} = 4.2 \text{ V}$ (representing fully charged and almost fully discharged two in-series cells) for $V_{\text{OUT}} = 1.8 \text{ V}$.

In this test, the TPS62840 device operates at $V_{\text{OUT}} = 3.3 \text{ V}$ to power the NB-IoT modules. With a smaller voltage level difference between V_{IN} and V_{OUT} , it will deliver several percent points higher efficiency numbers than those in the data sheet plot.

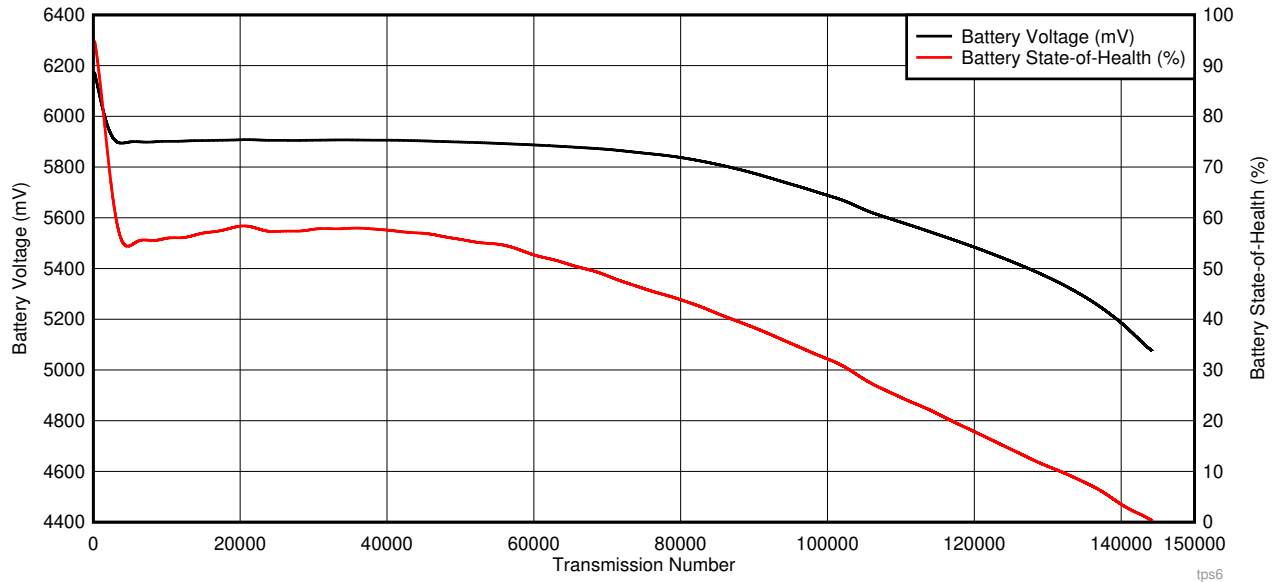
3.2.2.3 Test Results With the TPS610995 Boost Converter

图 14. TPS610995 Boost Battery Discharge Graph (1s Configuration)

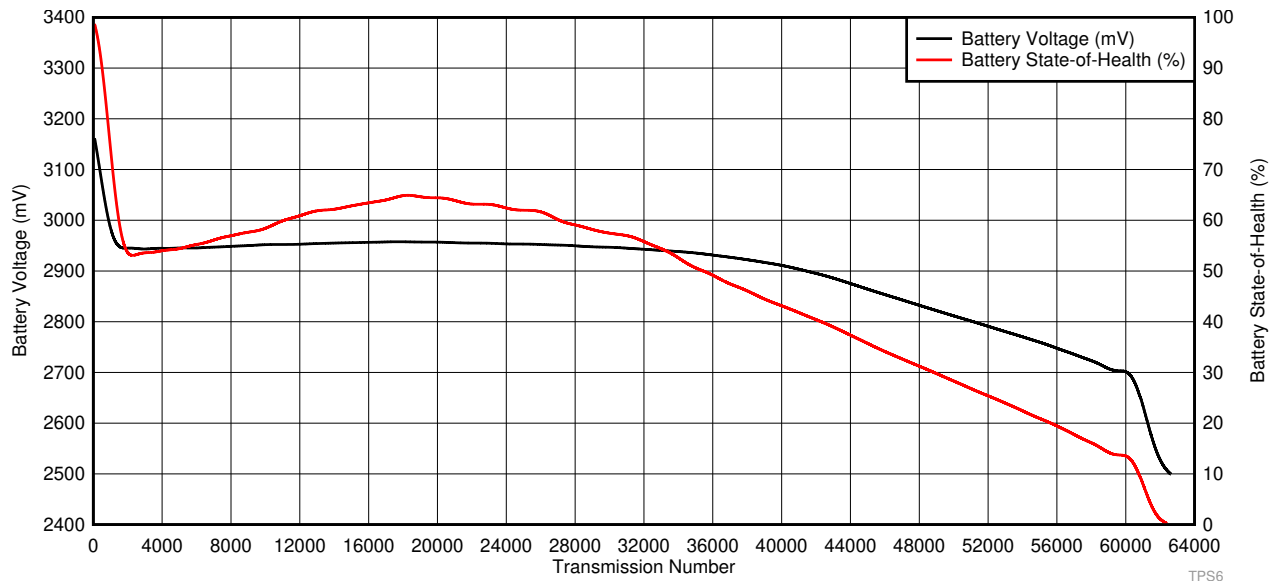

The bump in the voltage and SOH curve around 60,000 transmissions is a result of the test set up being disturbed, giving the battery time to relax, which is visible through the voltage rising.

图 14 highlights how using this power solution for an NB-IoT module, **63,000** transmissions can be supported. Similarly to the buck converter discharge data, stand-by current will play an added role in a field application, in addition to the 250-mA pulses. Based on the findings in 节 3.2.2.1, the total transmit cycle quantity can be approximated to fall between **30,833** and **63,000**, if the battery spends its complete lifetime between 20–30°C.

As detailed in 节 3.2.2.2, the BQ35100 device will perform best once the cell voltage starts decreasing more meaningfully. This can be observed around the midpoint at 35,000 transmissions where SOH equates to 50%, then the SOH reading becomes roughly linear and hones in on 0% SOH. See the FDK Lithium [CR17500EP LiMnO2 Primary Battery Data Sheet](#) to observe typical voltage discharge curves.

In this test, the TPS610995 device operates at $V_{OUT} = 3.6\text{ V}$ to power the NB-IoT modules. With a smaller voltage level difference between V_{IN} and V_{OUT} , it will deliver several percent points higher efficiency numbers than those in the data sheet plot.

Summary

Combining high-efficiency at light load, power converters with a primary battery gauge and a system health monitoring device deliver a unique capability: accurate measurement of the state-of-health (SOH) for LiMnO2 primary cells in NB-IoT enabled applications and report that information tirelessly over the cellular network. The system health monitor detects the high-current transmit pulse and triggers the time delay before the SOH measurement is made. The SOH measurement takes only 1 second and runs very infrequently, for example once in several days or weeks; the vast majority of the time the BQ35100 battery gauge is in shutdown mode consuming 50 nA (typical).

This in-system, real-time SOH ultra-low power measurement capability for IoT-related applications enables on-demand battery replacement and thus reduces the overall system cost. Instead of over dimensioning the cell capacity or simply replacing all cells after a pre-defined unit lifetime, designers now can get accurate SOH information per single unit and schedule the battery service only when this is necessary. As NB-IoT wireless network power settings are out of control for the IoT enabled devices and, in addition, the ever changing wireless environment is unpredictable, different units will experience a different discharge rate. The most accurate and cost-efficient solution is to measure in-system the battery discharge of each field-deployed unit and take action whenever the battery reaches a critical capacity level.

4 Design Files

4.1 Schematics

To download the schematics, see the design files at [TIDA-010053](#).

4.2 Bill of Materials

To download the bill of materials (BOM), see the design files at [TIDA-010053](#).

4.3 PCB Layout Recommendations

The PCB layout was made following the recommendations for each TPS controller device and using the EVM of each device as a design reference. Basically, the two EVMs are combined into a single PCB and a battery area for two AA-sized cells was added. The primary batteries must be soldered for best performance, hence FDK cells with leads are used.

4.3.1 Layout Prints

To download the layer plots, see the design files at [TIDA-010053](#).

4.4 Altium Project

To download the Altium Designer® project files, see the design files at [TIDA-010053](#).

4.5 Gerber Files

To download the Gerber files, see the design files at [TIDA-010053](#).

4.6 Assembly Drawings

To download the assembly drawings, see the design files at [TIDA-010053](#).

5 Software Files

There are no software files for [TIDA-010053](#); the software for the [TIDA-01546](#) design is updated with a UART communication port on J7 pins 5 (UART_TX) and pin 7 (UART_RX).

6 Related Documentation

1. [FDK CR17500EP Data Sheet](#)
2. [SARA-N211 Data Sheet](#)
3. [BC95-B8 Data Sheet](#)
4. [NB-IoT Application Development Guide by u-blox](#)
5. Texas Instruments, [Battery Management Studio \(bqStudio\) Software](#)
6. Texas Instruments, [BQ35100 Evaluation Module](#)

6.1 商标

E2E, DCS-Control, FemtoFET are trademarks of Texas Instruments.
Altium Designer is a registered trademark of Altium LLC or its affiliated companies.
microSD is a trademark of SD Association.
Wi-Fi is a registered trademark of Wi-Fi Alliance.
All other trademarks are the property of their respective owners.

6.2 Third-Party Products Disclaimer

TI'S PUBLICATION OF INFORMATION REGARDING THIRD-PARTY PRODUCTS OR SERVICES DOES NOT CONSTITUTE AN ENDORSEMENT REGARDING THE SUITABILITY OF SUCH PRODUCTS OR SERVICES OR A WARRANTY, REPRESENTATION OR ENDORSEMENT OF SUCH PRODUCTS OR SERVICES, EITHER ALONE OR IN COMBINATION WITH ANY TI PRODUCT OR SERVICE.

7 Terminology

NB-IoT — Narrowband Internet of Things radio technology developed by 3GPP and using low-power wide area network (LPWAN) to reach a wider area, over a long period in a small amount of data.

8 About the Author

MILEN STEFANOV (M.Sc.E.E) is a system engineer at TI, working in the Grid Infrastructure field and an expert in RF communication technologies and metering applications. After graduating, he spent 5 years as a research assistant at the University of Chemnitz (TUC) and 3.5 years in the semiconductor industry in high-speed optical and wired communications as a system engineer. He joined TI in 2003 to become a Wi-Fi® expert and support TI's Wi-Fi products at major OEMs. Since 2010, he has focused on metering and Sub-1 GHz RF solutions for the European Grid Infrastructure market. Mr. Stefanov has published multiple articles on wM-Bus technology in Europe and presented technical papers at the Wireless Congress and Smart Home and Metering summits in Munich.

SHUANG FENG is a Field Application Engineer in China who got his master's degree of circuit and system design at XIDIAN University. He supported Milen for the development of this reference design.

GRANT GRIFFIN is an Analog Field Applications Engineer in Michigan who got his bachelor's degree in Electrical Engineering from Michigan State University. In addition to Shuang Feng, he supported the development of this reference design.

修订历史记录

注：之前版本的页码可能与当前版本有所不同。

Changes from Original (July 2019) to A Revision	Page
更新了设计指南的标题.....	1
已更改 在整个设计指南中将不同电源架构的数量从三种更改为两种.....	1
修改了 说明 部分.....	1
通篇删除了对 TPS63802 的所有引用，从 资源 部分开始.....	1
修改了 特性 部分.....	1
更改了 应用 部分.....	1
Rewrote the System Description section.....	2
已更改 表 1 in the <i>Stand-by state duration</i> and <i>TX operations per hour</i> rows.....	3
已删除 all references to the TPS63803 device.....	4
Text and images redone in 节 3.2.2.2	20

重要声明和免责声明

TI 均以“原样”提供技术性 & 可靠性数据（包括数据表）、设计资源（包括参考设计）、应用或其他设计建议、网络工具、安全信息和其他资源，不保证其中不含任何瑕疵，且不做任何明示或暗示的担保，包括但不限于对适销性、适合某特定用途或不侵犯任何第三方知识产权的暗示担保。

所述资源可供专业开发人员应用 TI 产品进行设计使用。您将对以下行为独自承担全部责任：(1) 针对您的应用选择合适的 TI 产品；(2) 设计、验证并测试您的应用；(3) 确保您的应用满足相应标准以及任何其他安全、安保或其他要求。所述资源如有变更，恕不另行通知。TI 对您使用所述资源的授权仅限于开发资源所涉及 TI 产品的相关应用。除此之外不得复制或展示所述资源，也不提供其它 TI 或任何第三方的知识产权授权许可。如因使用所述资源而产生任何索赔、赔偿、成本、损失及债务等，TI 对此概不负责，并且您须赔偿由此对 TI 及其代表造成的损害。

TI 所提供产品均受 TI 的销售条款 (<http://www.ti.com.cn/zh-cn/legal/termsofsale.html>) 以及 [ti.com.cn](http://www.ti.com.cn) 上或随附 TI 产品提供的其他可适用条款的约束。TI 提供所述资源并不扩展或以其他方式更改 TI 针对 TI 产品所发布的可适用的担保范围或担保免责声明。

邮寄地址：上海市浦东新区世纪大道 1568 号中建大厦 32 楼，邮政编码：200122
Copyright © 2020 德州仪器半导体技术（上海）有限公司

重要声明和免责声明

TI 均以“原样”提供技术性 & 可靠性数据（包括数据表）、设计资源（包括参考设计）、应用或其他设计建议、网络工具、安全信息和其他资源，不保证其中不含任何瑕疵，且不做任何明示或暗示的担保，包括但不限于对适销性、适合某特定用途或不侵犯任何第三方知识产权的暗示担保。

所述资源可供专业开发人员应用 TI 产品进行设计使用。您将对以下行为独自承担全部责任：(1) 针对您的应用选择合适的 TI 产品；(2) 设计、验证并测试您的应用；(3) 确保您的应用满足相应标准以及任何其他安全、安保或其他要求。所述资源如有变更，恕不另行通知。TI 对您使用所述资源的授权仅限于开发资源所涉及 TI 产品的相关应用。除此之外不得复制或展示所述资源，也不提供其它 TI 或任何第三方的知识产权授权许可。如因使用所述资源而产生任何索赔、赔偿、成本、损失及债务等，TI 对此概不负责，并且您须赔偿由此对 TI 及其代表造成的损害。

TI 所提供产品均受 TI 的销售条款 (<http://www.ti.com.cn/zh-cn/legal/termsofsale.html>) 以及 [ti.com.cn](http://www.ti.com.cn) 上或随附 TI 产品提供的其他可适用条款的约束。TI 提供所述资源并不扩展或以其他方式更改 TI 针对 TI 产品所发布的可适用的担保范围或担保免责声明。

邮寄地址：上海市浦东新区世纪大道 1568 号中建大厦 32 楼，邮政编码：200122

Copyright © 2020 德州仪器半导体技术（上海）有限公司