

设计指南: TIDA-01580

用于医疗和消费类可穿戴设备的无线 ECG、SpO2、PTT 和心率监护仪参考设计



说明

本参考设计是一种简单的可穿戴多参数患者监护仪设计, 该设计采用单芯片生物传感前端 AFE4900 器件, 适用于同步心电图 (ECG) 和光体积描记器 (PPG) 测量。测量数据通过 CC2640R2F 器件 (支持 BLE 4.2 和 5) 传输到远程位置。参考设计由单节 CR3032 电池驱动运行, 电池寿命为 30 天。用户可使用原始数据计算心率、血氧饱和度 (SpO2)、脉搏传导时间 (PTT) 和 ECG。两个板载发光二极管 (LED) 可为用户指示低电量检测和 ECG 导联脱落检测情况。

资源

TIDA-01580	设计文件夹
AFE4900	产品文件夹
CC2640R2F	产品文件夹
TPS61099	产品文件夹
TPS63036	产品文件夹
TPD1E10B06	产品文件夹



咨询我们的 E2E™ 专家

特性

- 简单可穿戴多参数患者监护仪, 适用于 PPG 和 ECG
- 提供原始数据, 用于计算心率、SpO2 和 PTT
- 使用单芯片生物传感前端 AFE4900 器件, 可实现同步 ECG 和 PPG 测量
 - PPG (光学心率监控和 SpO2) 支持四个 LED 和三个光电二极管 (PD), 具有数字环境消减功能, 可提高信噪比 (SNR)
 - ECG (LEAD I) 信号
- 集成 Arm® Cortex®-M3 和 2.4GHz 射频收发器 (CC2640R2F) 支持无线数据传输 – BLE 4.2 和 5.0
- 由 CR3032 (3V 500mA 纽扣电池) 供电, 采用高效直流/直流转换器, 电池寿命长达 30 天
- 外形小巧, 可轻松穿戴 应用

应用

- 医疗传感器贴片
- ECG
- 脉动式血氧计
- 可穿戴健身和活动监测仪
- 智能手表
- 智能追踪器

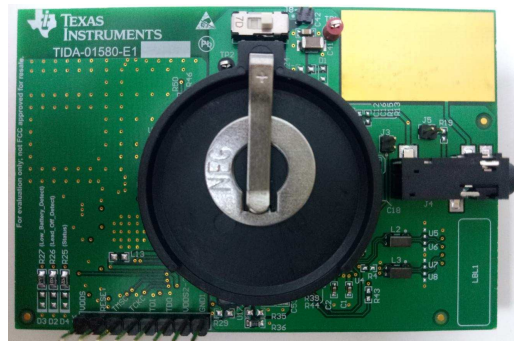
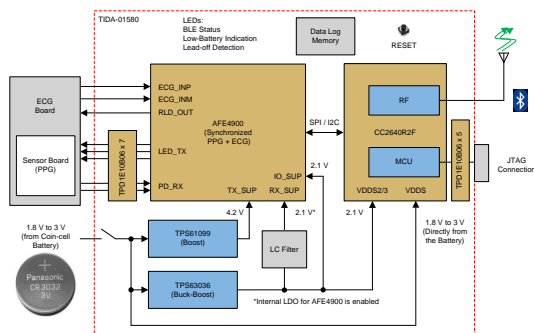

该 TI 参考设计末尾的重要声明表述了授权使用、知识产权问题和其他重要的免责声明和信息。

Important Disclaimer Information

WARNING

TI products may not be used in life-critical medical equipment unless authorized officers of the parties have executed a special contract specifically governing such use. See our [Terms of Sale](#) for additional information.

1 System Description

1.1 Introduction to Parameters Measured Using TIDA-01580

The TIDA-01580 device can be used to measure the following parameters: ECG, PPG, HRM, SpO2, and PTT.

ECG is an electrical measurement of the activity in the heart whereas PPG is an optical measurement of the volume of an organ. In principle, ECG uses multiple electrodes to measure the electrical activity of the heart, whereas PPG illuminates the skin and subcutaneous tissue with light of a specific wavelength from a light-emitting diode (LED) to measure organ volume. This light is absorbed, passed through, or reflected back. A photodiode sensor measures the light that is either transmitted or reflected, depending on where it is placed relative to the LED. The light is then converted to an electrical signal. In both cases, the information can be used to determine the heart rate of a person, but each application offers its own set of diagnostic information. ECG focuses on the electrical activity of the cardiac muscle tissue, because the exact sequence of contraction is well-known to trained cardiologists. Physicians use ECG to diagnose all kinds of heart diseases and abnormalities. PPG provides more information about blood flow and blood pressure. This measurement can be conducted at various locations on the body, to examine the blood flow to different regions. When measured closest to the aorta of the heart (for example, the left arm), some additional information can be gained regarding the cardiac output and heart valve function. One advantage that PPG has is the number of skin contacts which are required to measure it. Because users can determine PPG from reflected or transmitted light, only a single point of contact is necessary to measure it. This feature allows for easy, continuous, time measurements, which is the most attractive advantage to wearable electronics such as fitness trackers. In contrast, ECG requires that the potential be measured across the heart. This means that users need at least two points of contact: positive and negative. Typically, this connection is only made for a finite period of time.

图 1 shows the typical waveforms for ECG (blue) and PPG (red). The time difference between the R-peak in the ECG waveform and the arrival of the blood pressure wave in the extremities is another measurement known as PTT. PTT involves simultaneous measurement of ECG and PPG.



图 1. Introduction to ECG, PPG, and PTT

Because the frequency of both ECG and PPG signals is same, heart rate can be calculated using both waveforms. Mostly green LEDs are used for measuring heart rates. A green LED has often been used in the reflective sensor to extract the PPG signal. Due to its wavelength, green light is known to penetrate the tissue less than higher wavelength LEDs. Hence, more unabsorbed (reflected) light comes out of the tissue with green than with other colors. Sensing the green light from more than one PD or eliminating from more than one LED surrounding the PD helps.

Red and infrared (IR) lights are used for pulse oximetry, to estimate the true hemoglobin oxygen saturation of arterial blood. Oxyhemoglobin (HbO₂) absorbs visible and infrared IR light differently than deoxyhemoglobin (Hb), and appears bright red as opposed to the darker brown of Hb. Absorption in the arterial blood is represented by an AC signal that is superimposed on a DC signal, representing absorptions in other substances like pigmentation in tissue, venous, capillary, bone, and so forth. The cardiac-synchronized AC signal is approximately 1% of the DC level. This value is referred to as the perfusion index %. 公式 1 approximates the ratio of ratios, R, and % SpO₂ is calculated as follows:

$$R = \frac{\frac{\text{ACrms of Red}}{\text{DC of Red}}}{\frac{\text{ACrms of IR}}{\text{DC of IR}}} \tag{1}$$

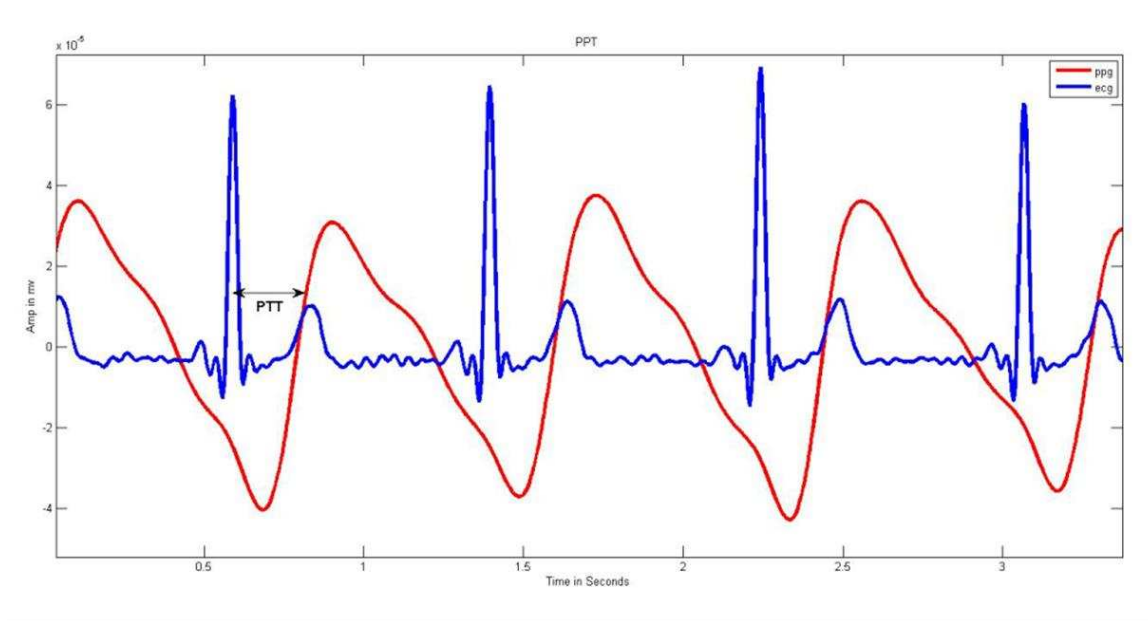
公式 2 gives the standard model of computing SpO₂. This model is often used in this literature in the context of medical devices. However, accurate % SpO₂ is computed based on the empirical calibration of the ratio of ratios for the specific device.

$$\%SpO_2 = 110 - (25 \times R) \tag{2}$$

1.2 High-Level System Description

Typically wireless, wearable, patient monitors are tied to the human body in such a way that they can measure multiple parameters for the body. 图 2 shows a high-level block diagram of such a system. A typical patient monitor has a radio module, or radio IC, on it and operates over a battery. The communication can be established from a remote location (like a cell phone, tablet, or a computer).



图 2. System-Level Block Diagram

1.3 Typical Applications

- **Medical sensor patches:** Medical sensor patches measure vital signs and send data across to a remote location through wireless technology (Bluetooth®, BLE, Wi-Fi®, or NFC). These monitors are typically battery-powered and have low operating currents, to work for longer battery life. The solutions are notably compact, unlike bedside multi-parameter patient monitors.
- **Wearable Fitness and Activity Monitor:** Fitness monitors measure both the amount and rate of exercise of a person (for example, miles and pace run), as well as effort expended (for example, through monitoring heart rate). Typically, a wristwatch or wrist-worn display is used for control and providing feedback. Stored data can be downloaded to a computer through a USB or wireless USB dongle. All parts of the system require ultra-low-power, embedded controllers and low-power RF for communication. Heart-rate monitoring and exercise-output monitoring (for example, a running pace sensor or power sensor) require additional signal conditioning.
- **ECG:** Basic functions of an ECG machine include ECG waveform display, either through an LCD screen or printed paper media, and heart rhythm indication, as well as a simple user interface through buttons. Additional features are required in more and more ECG products, such as patient-record storage using convenient media, wireless or wired transfer, and 2D/3D display on a large LCD screen with touchscreen capabilities. Multiple levels of diagnostic capabilities also assist doctors and people without specific ECG training to understand ECG patterns and their indication of a certain heart condition. After the ECG signal is captured and digitized, it is sent for display and analysis, which involves further signal processing.
- **Pulse Oximeter:** The pulse oximeter measures blood oxygenation by sensing the IR and red-light absorption properties of deoxygenated and oxygenated hemoglobin. The oximeter is comprised of a sensing probe that attaches to the ear lobe, toe, or finger of a patient, and is connected to a data acquisition system for calculation and display of the oxygen saturation level, heart rate, and blood flow. Light sources, typically LEDs, shine visible red and IR light. Deoxygenated hemoglobin allows more infrared light to pass through and absorbs more red light. Highly oxygenated hemoglobin allows more red light to pass through and absorbs more IR light. The oximeter senses and calculates the amount of light at those wavelengths, proportional to the oxygen saturation (or desaturation) of the hemoglobin. The use of light in the absorbency measurement requires the designer to have a true light-to-voltage conversion using current as the input signal.

1.4 System Specifications and Design Features

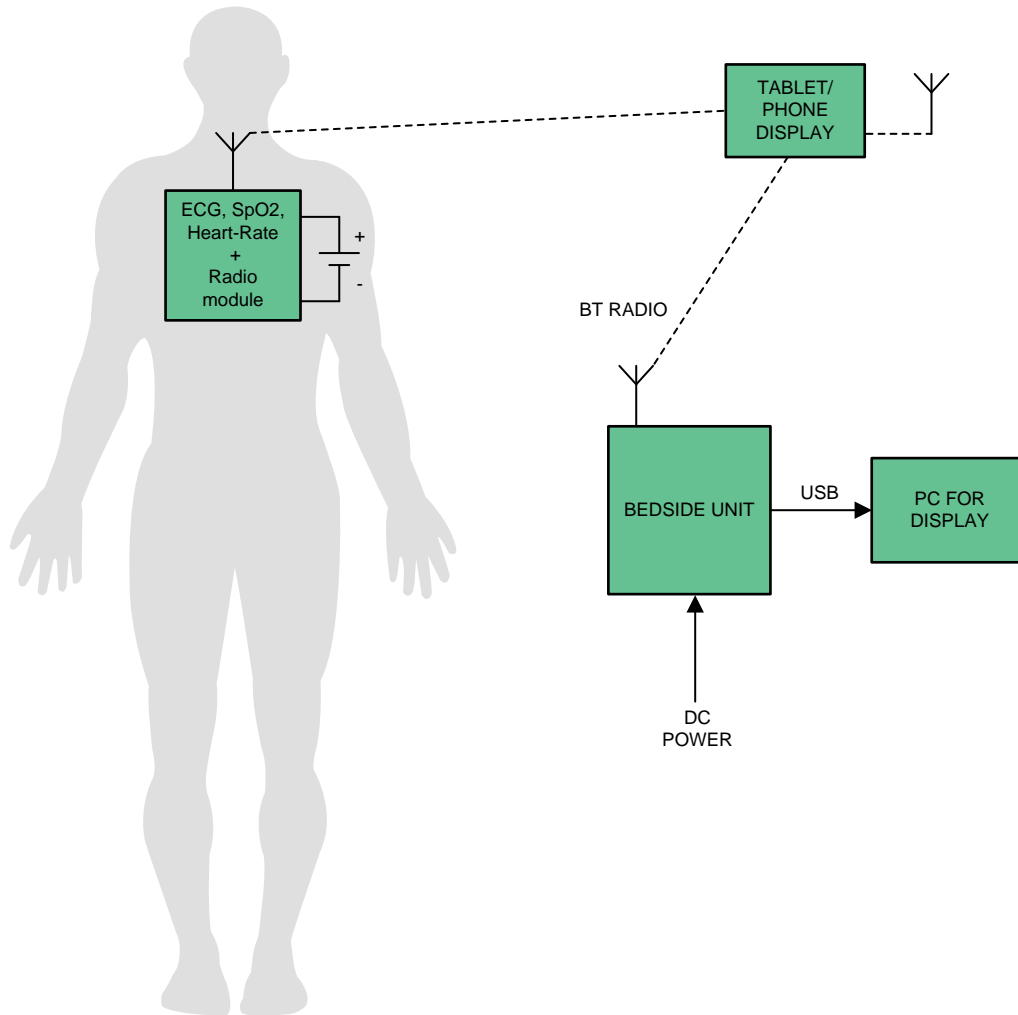
The TIDA-01580 reference design realizes a wearable patient monitor and has following design features:

- Simple, wearable, multi-parameter, patient monitor that provides raw data to calculate heart rate, SpO2, and PTT
- Single-chip, biosensing, front-end for synchronized ECG and PPG measurements (AFE4900 device)
 - Only device on the market with this level of integration, low power, size, and flexibility
 - PPG (optical heart-rate monitoring and SpO2) supports 4 LEDs and 3 PDs with digital ambient subtraction to improve the SNR
 - ECG (LEAD I) signals
 - Flexibility of ultra-low-power modes and integrated FIFO can keep the MCU in sleep mode to increase the battery operation time
- Wireless data transfer supporting BLE 4.2 and 5.0
 - Integrated Arm Cortex-M3 and 2.4-GHz RF transceiver (CC2640R2F device)
 - Internal DC/DC converter helps improve the overall efficiency
 - Built-in, low-battery detection algorithm helps reduce the external components
 - Better routing in small form factor (all digital peripheral pins can be routed to any GPIO)
- Operated from CR3032 (3-V, 500-mA coin-cell battery), which offers 100 hours of continuous operation
- Low-power (battery life of 30 days for 1 second/minute transmission)
- Can also be operated using CR2032 (3-V, 225-mA coin cell battery) with reduced operating time
- Plug-in board approach enables easy adaptation to custom PPG sensors

1.5 Key System Specifications

表 1 lists the different characteristics and specifications of the TIDA-01580 board.

表 1. Key System Specifications

CHARACTERISTICS	SPECIFICATIONS
Input voltage (V_{IN})	1.8 V to 3 V (coin-cell CR3032 battery)
TX_SUP	4.2 V
RX_SUP	2.1 V
IO_SUP	2.1 V
Number of LEDs for PPG measurement	Three (green, red, and IR)
Number of photo diodes for PPG measurement	Two (for SFH7072)
	One (for OCS112)
Number of electrodes for ECG measurement	Two (Lead-I) for standard operation (support for three electrodes is possible with a few modifications on the board)
ECG lead-off detection	AC
External memory	Supported, but not populated onboard
LED indications	Lead-off detect
	Low-battery flag
	BLE status
Communication	SPI
Interface to controller	8-pin connector (100 mil, part number PRPC008SADN-RC)

2 System Overview

2.1 Block Diagram

图 3 shows the high-level block diagram for the TIDA-01580 device, which is a simple, wearable, multi-parameter, patient monitor. The AFE4900 is a single-chip, biosensing, front end for synchronized ECG and PPG measurements. The AFE4900 device can drive LEDs and support receive signal chains for the photo diodes. The AFE4900 device communicates with the CC2640R2F device over SPI (or I²C). The CC2640R2F is a microcontroller with an integrated Arm Cortex-M3 and 2.4-GHz RF transceiver. The design supports wired data capture using a JTAG connection, as well as wireless data capture by sending it over BLE through the antenna.

The board is powered using a 3-V, 500-mA coin-cell battery, CR3032. A boost converter (TPS61099) powers TX_SUP for the AFE4900 device, which supports the internal LED drivers for PPG measurement. A buck-boost converter (TPS63036) powers RX_SUP and IO_SUP for the AFE4900 device and VDDSD2 and VDDSD3 for the CC2640R2F device. VDDSD for the CC2640R2F device is directly powered by the battery.

The board supports connections to external data-log memory, but it is currently not populated. The board indicates battery power source availability, low-battery detection, BLE connection status, and lead-off detection through onboard LEDs.

All the connections from the main to the external world are protected by ESD diodes (TPD1E10B06). The design contains a main board, an ECG board, and a sensor board.



图 3. TIDA-01580 Block Diagram

2.2 Highlighted Products

Key features of the highlighted devices are mentioned in the following sections.

2.2.1 AFE4900

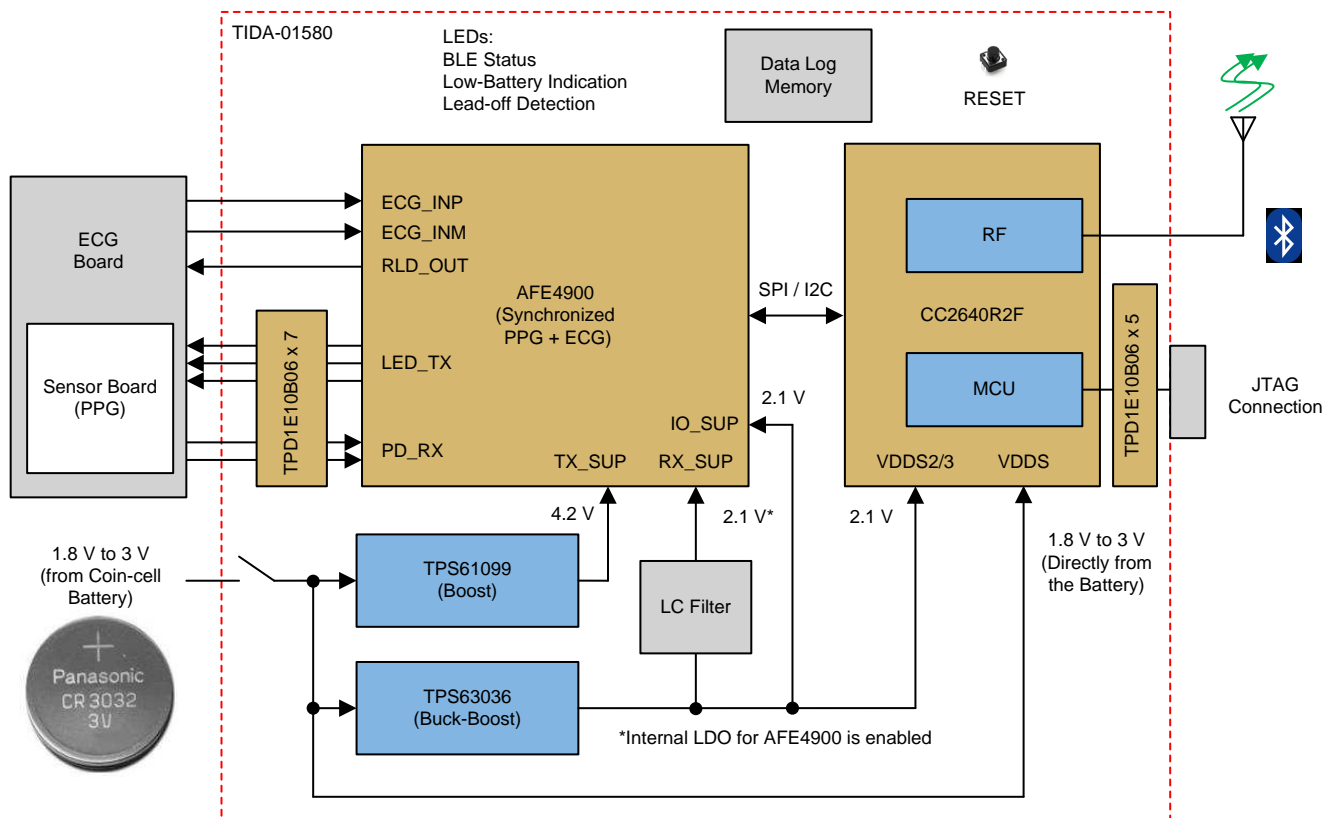
The AFE4900 device is an analog front-end (AFE) for synchronized ECG and PPG signal acquisition. The device can also be used for optical biosensing applications, such as heart-rate monitoring (HRM) and SpO₂. The PPG signal chain supports up to four switching LEDs and up to three PDs. The LEDs can be switched on using a fully-integrated LED driver. The current from the PD is converted into voltage by the trans-impedance amplifier (TIA) and digitized using an analog-to-digital converter (ADC). The ECG signal-chain has an instrumentation amplifier (INA), with a programmable gain that interfaces to the same ADC. A right-leg drive (RLD) amplifier set can be used to bias the ECG input pins. AC and DC lead-off detect schemes are supported. The ADC codes from the PPG and ECG phases can be stored in a 128-sample first in, first out (FIFO) block and read out using either an I²C or SPI.

2.2.2 CC2640R2F

The CC2640R2F device is a wireless MCU targeting BLE 4.2 and 5 applications. The device is a member of the SimpleLink™ ultra-low-power CC26xx family of cost-effective, 2.4-GHz RF devices. Low active RF and MCU current and low-power mode current consumption provide excellent battery lifetime and allow for operation on small coin-cell batteries and in energy-harvesting applications. The SimpleLink BLE CC2640R2F device contains a 32-bit Arm Cortex-M3 core, which runs at 48 MHz as the main processor and a rich peripheral feature set, which includes a unique ultra-low power sensor controller. This sensor controller is ideal for interfacing external sensors and for collecting analog and digital data autonomously while the rest of the system is in sleep mode. Thus, the CC2640R2F device is great for a wide range of applications where long battery lifetime, small form factor, and ease of use are important. The power and clock management and radio systems of the CC2640R2F wireless MCU require specific configuration and handling by software, which has been implemented in the TI-RTOS, to operate correctly.

2.2.3 TPS61099

The TPS61099 boost converter uses a hysteretic control topology to obtain maximum efficiency at minimal quiescent current. The TPS61099 device only consumes 1- μ A quiescent current under a light load condition and can achieve up to 75% efficiency at a 10- μ A load with a fixed output voltage version. The TPS61099 device can also support up to 300-mA output current from 3.3 V to 5 V conversion and achieve up to 93% at a 200-mA load. The TPS61099 device also offers both Down Mode and Pass-Through operations for different applications. In Down Mode, the output voltage can still be regulated at a target value even when the input voltage is higher than the output voltage. In Pass-Through Mode, the output voltage follows the input voltage. The TPS61099x device exits Down Mode and enters into Pass-Through Mode when $V_{IN} > V_{OUT} + 0.3$ V. The TPS61099x device supports true shutdown function when it is disabled, which disconnects the load from the input supply to reduce the current consumption. The TPS61099x device offers both an adjustable output voltage version and fixed output voltage version. The TPS61099x device is available in a 6-ball, 1.23-mm \times 0.88-mm, WCSP package.

2.2.4 TPS63036

The TPS63036 is a noninverting, buck-boost converter capable of providing a regulated output voltage from an input supply that can be higher or lower than the output voltage. The buck-boost converter is based on a fixed-frequency, pulse width modulation (PWM) controller, which uses synchronous rectification to obtain maximum efficiency. At low-load currents, the converter enters a power-save mode to maintain high efficiency over a wide-load current range. The power save mode can be disabled, forcing the converter to operate at a fixed switching frequency. The maximum average current in the switches is limited to a typical value of 1000 mA. The output voltage is programmable using an external resistor divider. The converter can be disabled to minimize battery drain.

2.2.5 TPD1E10B06

The TPD1E10B06 device is a single-channel, electrostatic discharge (ESD), transient voltage suppression (TVS) diode in a small 0402 package. This TVS protection product offers ± 30 -kV contact ESD, ± 30 -kV IEC air-gap protection, and an ESD clamp circuit, with a back-to-back TVS diode for bipolar or bidirectional signal support. The 0402 package is an industry standard and is convenient for component placement in space-saving applications.

2.3 System Design Theory and Design Considerations

This section explains the design theory (and equations, if required) for each of the devices used in the design.

2.3.1 AFE4900 and Power Supply

图 4 shows different connections for the AFE4900 device.

The AFE4900 device needs three power supplies: TX_SUP, RX_SUP, and IO_SUP. TX_SUP (4.2 V) is generated using the TPS61099 device. RX_SUP (2.1 V) is generated using the TPS63036 device. IO_SUP is the same as RX_SUP.

For PPG measurement, the LEDs are driven using the TX2, TX3, and TX4 pins (TX1 is not connected in the design). The reflected signals are detected using PDs connected to the INP-INM and INP2-INM2 pins (INP3-INM3 pins are not connected in the design).

For ECG measurement, the signals coming from electrodes are connected to the INP_ECG and INM_ECG pins. The right-leg drive signal is available on RLD_OUT pin.

The BG pin is connected to the internal bandgap voltage. The BG pin is decoupled using a 0.1- μ F capacitor (C11) on the board.



图 4. AFE4900 Connections Schematic

For the AFE4900 device, RX_SUP is filtered using an LC filter consisting of the ferrite bead L1 and capacitors C6 and C7.

表 2 lists the connections between the AFE4900 and CC2640R2F devices.

表 2. Connections Between AFE4900 and CC2640R2F

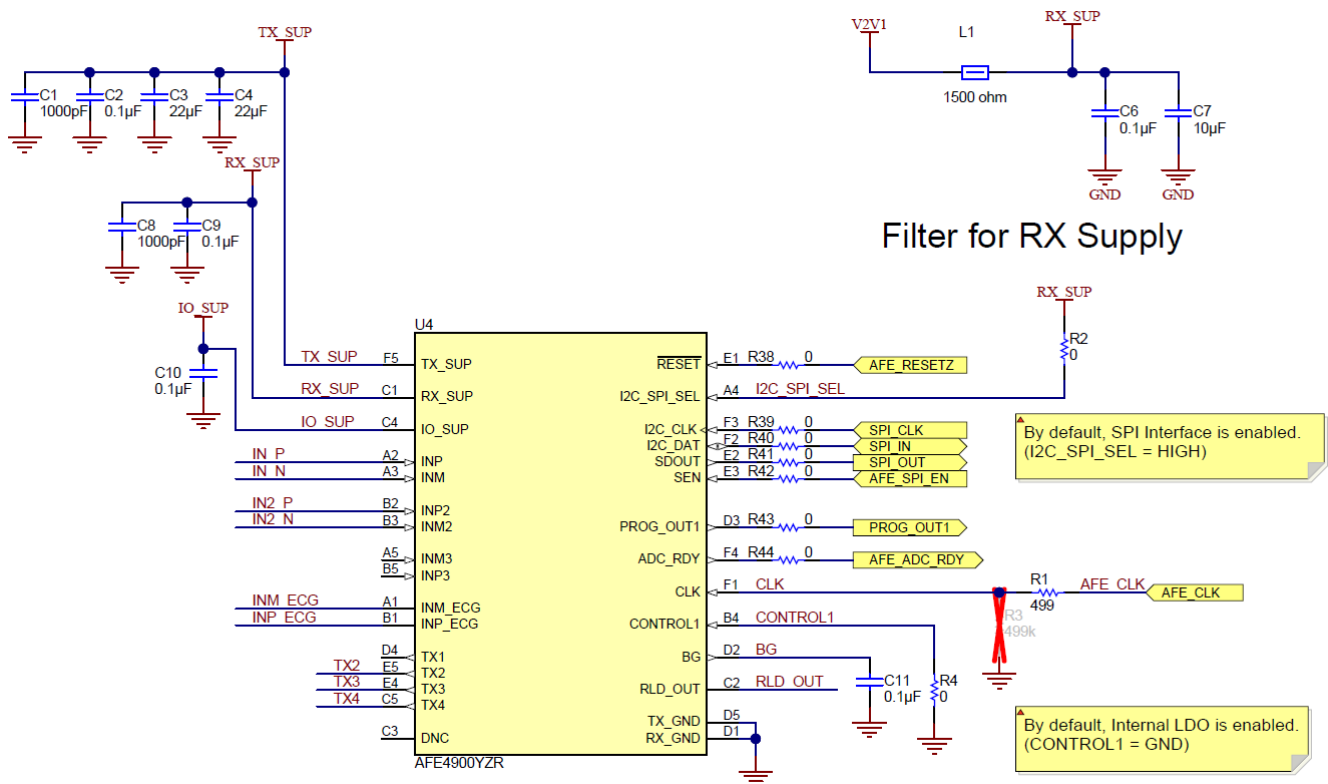
AFE4900 PIN NUMBER	FUNCTION	CC2640R2F PIN NUMBER	FUNCTION	COMMENTS
E1	/RESET	6	DIO_1	Reset for the AFE
A4	I2C_SPI_SEL	N/A	N/A	Selection between SPI and I ² C. For this design, SPI is selected, so this pin is connected to RX_SUP through a 0-Ω resistor (R2).
F3	I2C_CLK	16	DIO_10	SPI_CLK
F2	I2C_DAT	14	DIO_8	SPI_IN
E2	SDOUT	15	DIO_9	SPI_OUT
E3	SEN	5	DIO_0	AFE_SPI_EN
D3	PROG_OUT1	21	DIO_15	
F4	ADC_RDY	28	DIO_18	ADC ready signal
F1	CLK	29	DIO_19	AFE clock
B4	CONTROL1	N/A	N/A	Enables or disables the internal LDO. For this design, the internal LDO is enabled, so this pin is connected to GND through a 0-Ω resistor (R4).

2.3.2 CC2640R2F Microcontroller

图 5 shows the schematic for configuring the CC2640R2F MCU.



图 5. CC2640R2F MCU Schematic

The VDD5 power supply for the MCU, 2.1 V, is derived using the TPS63036 device. The VDDR power supply is generated using the internal DC/DC of the CC2640R2F MCU, and L8, C20, C25, and C27 form the filter components for the same. Y1 is the 24-MHz, high-frequency, external clock and Y2 is the 32-kHz, low-frequency, external clock. The GPIO pins of the CC2640R2F MCU (DIO_0 to DIO_30) interface with different functions such as Memory interface lines, AFE4900 interface lines, SPI communication, LED drives, and so on.

The RF front end is used in differential-ended configurations with internal biasing. A Balun LFB182G45BG5D920 device is used for the RF front end and tuned for application. J7 is a connector for conducted RF measurements (if required). The antenna is a PCB antenna.

VDDS Decoupling Capacitors

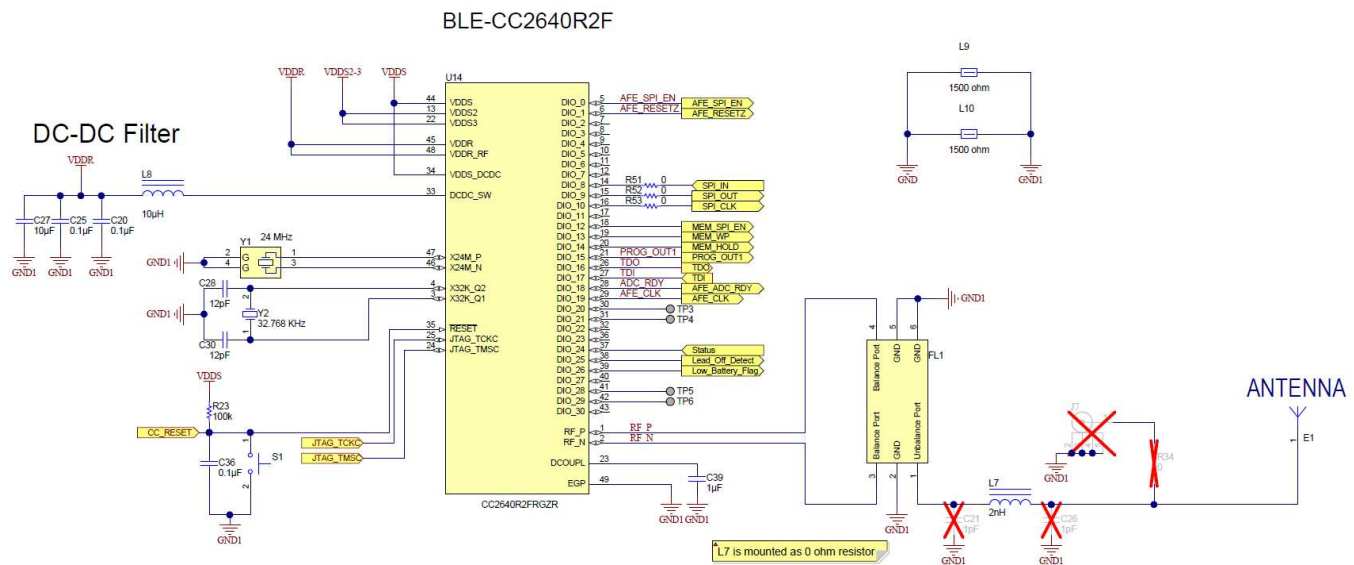
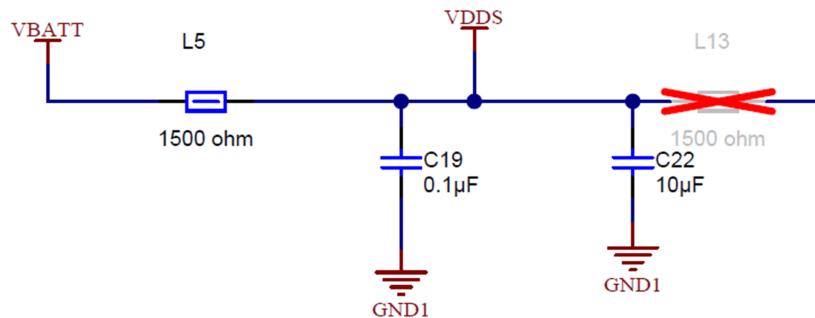

VDDS2-3 Decoupling Capacitors



图 6. Decoupling for CC2640R2F MCU

VBATT is connected to VDDSS through L5 (a GHz noise-suppression chip ferrite bead), providing a low-noise supply to the MCU. C19 and C22 are the decoupling capacitors. A 2.1 V is connected to the VDDS2 and VDDS3 pins through L6 (a GHz noise-suppression chip ferrite bead), providing a low-noise supply to the MCU. C23 and C24 are the decoupling capacitors (see 图 6).

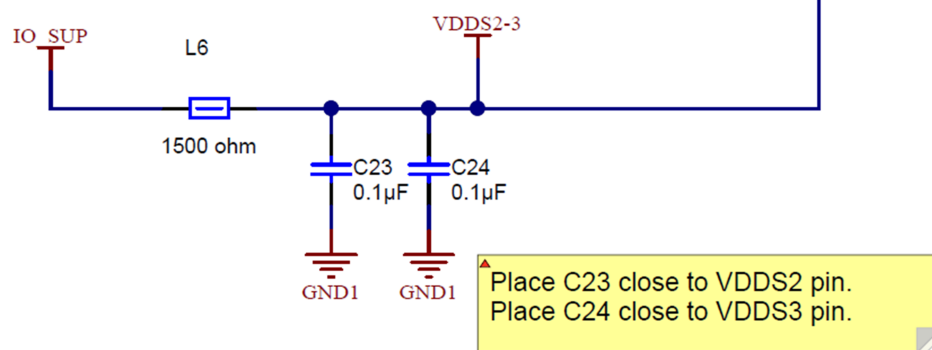

图 7. MCU Programming Connector

The MCU is programmed using a JTAG connection, as shown in 图 7. The connector inputs are protected by ESD diodes (TPD1E10B06DPYR) from Texas Instruments. The TPD1E10B06 device is a single-channel, ESD, TVS diode in a small 0402 package. This TVS protection product offers ±30-kV contact ESD, ±30-kV IEC air-gap protection, and an ESD clamp circuit, with a back-to-back TVS diode for bipolar or bidirectional signal support.

2.3.3 PPG Measurement

For PPG measurement, three LEDs and two PDs are used in a single package. 表 3 lists details about the OCS112 (from Taiwan Biophotonic Co.) and SFH7072 (from OSRAM®).

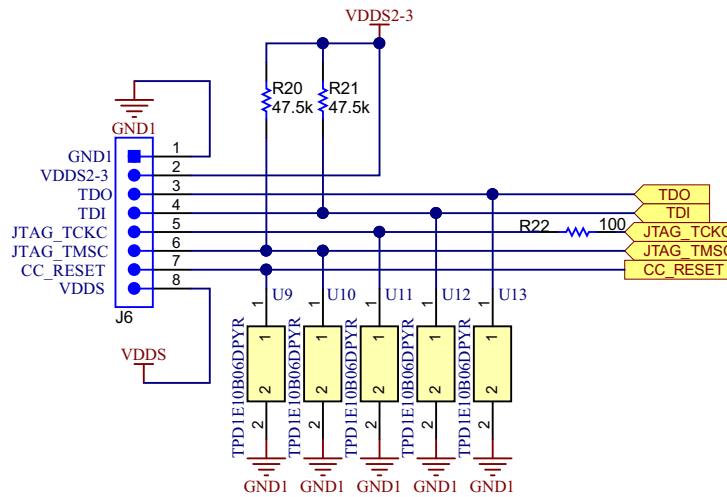
表 3. Optical Sensors

SENSOR	OCS112	SFH7072
Number of LEDs	3	4
Number of PDs	1	2
LED1 color	Red	Green
LED1 wavelength	655 nm	526 nm
LED2 color	IR	Green
LED2 wavelength	945 nm	526 nm
LED3 color	Green	Red
LED3 wavelength	525 nm	660 nm
LED4 color	-	IR
LED3 wavelength	-	950 nm
LED1 VF (typ)	2.1	1.3
LED1 VF (max)	2.4	1.8
LED2 VF (typ)	1.4	2.1
LED2 VF (max)	1.55	2.8
LED3 VF (typ)	3.2	3
LED3 VF (max)	3.7	3.4
LED4 VF (typ)	-	3
LED4 VF (max)	-	3.4

The Sensor boards are designed to fit on the main board with 5-pin connectors, based on the LEDs and PDs available in the Optical Sensor. All the LEDs are configured in push-pull (common anode mode). See 图 8 and 图 9 for the connection diagrams.



图 8. Sensor Board Schematic With SFH7072 Device



图 9. Sensor Board Schematic With OCS112 Device

The Sensor boards are fit onto the main board using the J1 and J2 connector, as shown in 图 10.

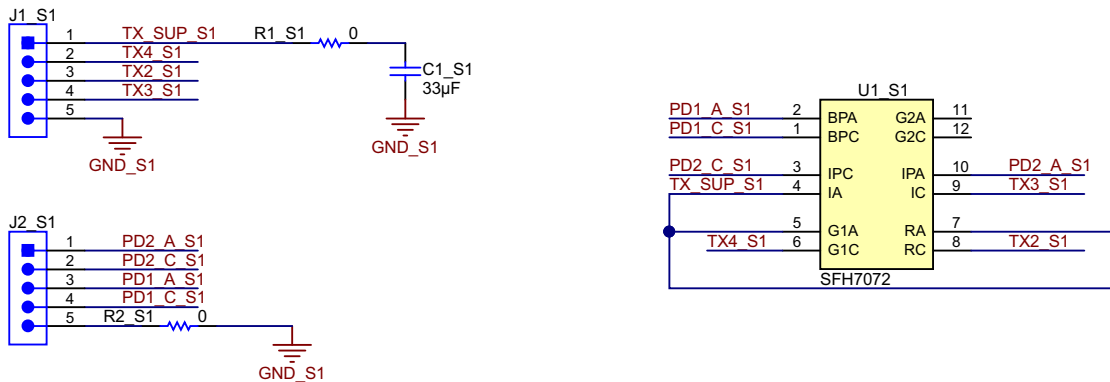

图 10. PPG Connection From Sensor Board to AFE4900 Device on Main Board

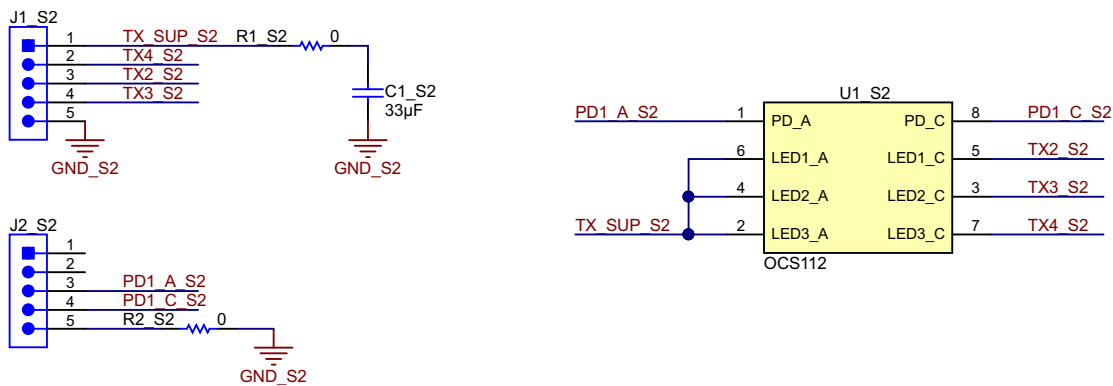
The J1 connector has 5 connections: TX_SUP, TX drive pins, and GND. The J2 connector has 5 connections: PD1 Anode and Cathode, PD2 Anode and Cathode, and GND. The connector inputs are protected using ESD diodes (TPD1E10B06DPYR) from Texas Instruments. The TPD1E10B06 device is a single-channel, ESD, TVS diode in a small 0402 package. This TVS protection product offers ± 30 -kV contact ESD, ± 30 -kV IEC air-gap protection, and an ESD clamp circuit with a back-to-back TVS diode for bipolar or bidirectional signal support. The TX_SUP pin is decoupled using a 33- μ F capacitor.

The PD signals are filtered using SMD Common Mode Chokes (having specifications as 90 Ω at 100 MHz, 370-mA DCR 300 m Ω). The chokes help in improving the immunity to external common mode noise signals and improve overall SNR of the system.

2.3.4 ECG Measurement

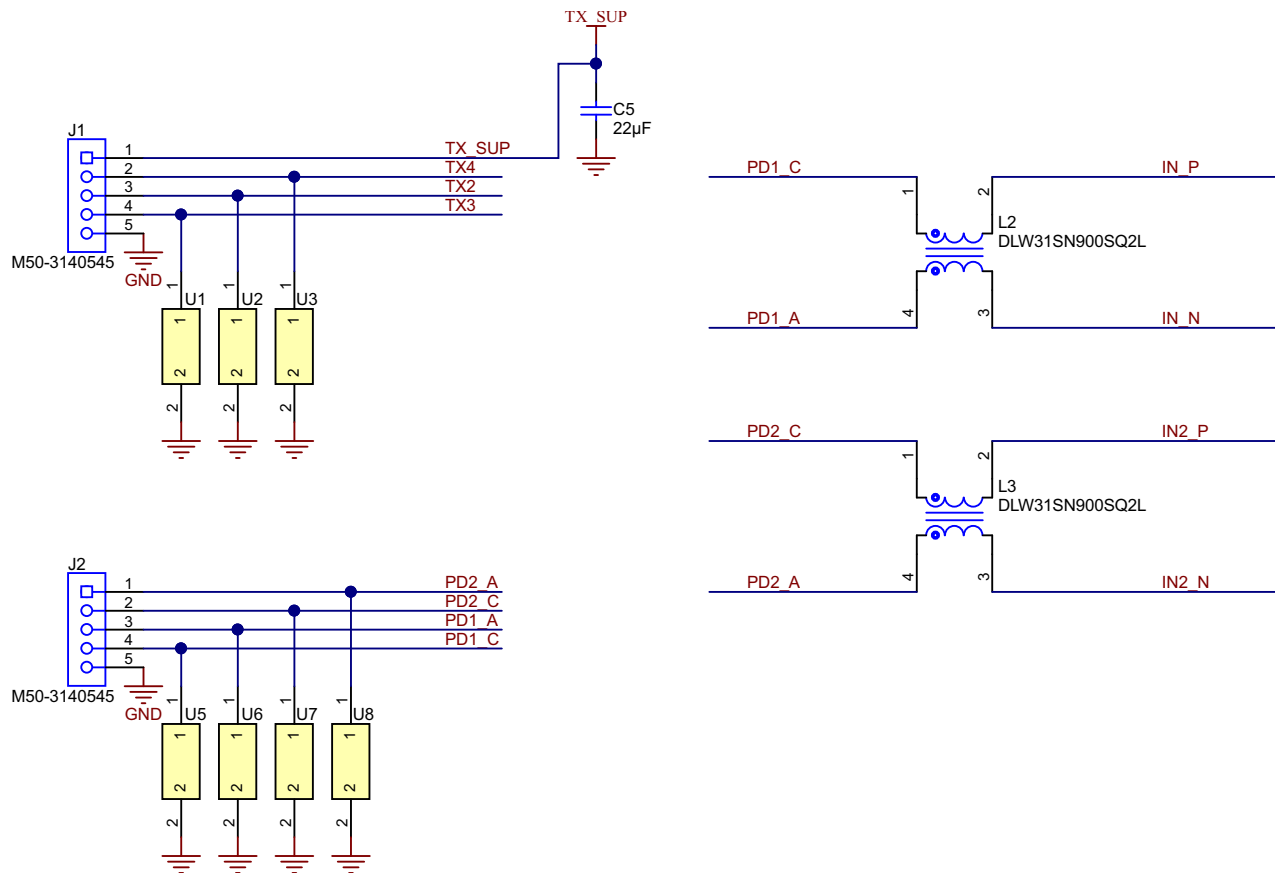
The single-lead ECG measurement can be done using either two electrodes or three electrodes. The ECG signal is acquired as the differential signal between the right-arm and left-arm electrodes. The RLD electrode is used to set the bias on the body. The filtering for the signal can be first order or second order (based on frequency roll-off requirement). The electrode-to-skin contact impedance can be modeled as a parallel R-C circuit comprising of 620kohm and 4700 pF.

2.3.4.1 Two-Electrode Configuration

This configuration does not use a third wire or connection for RLD. The common mode voltage is provided to the inputs using a resistor divider network, as shown in 图 11. The signals coming from the electrodes are AC-coupled using capacitors.



图 11. Interface for ECG Measurement (Two Electrodes)

2.3.4.2 Three-Electrode Configuration

This configuration uses a third wire or connection for RLD. The common mode voltage is provided to the inputs using the RLD terminal shown in 图 12. The signals coming from the electrodes are directly connected to the inputs of the AFE. The body connections should happen with the metal pads.

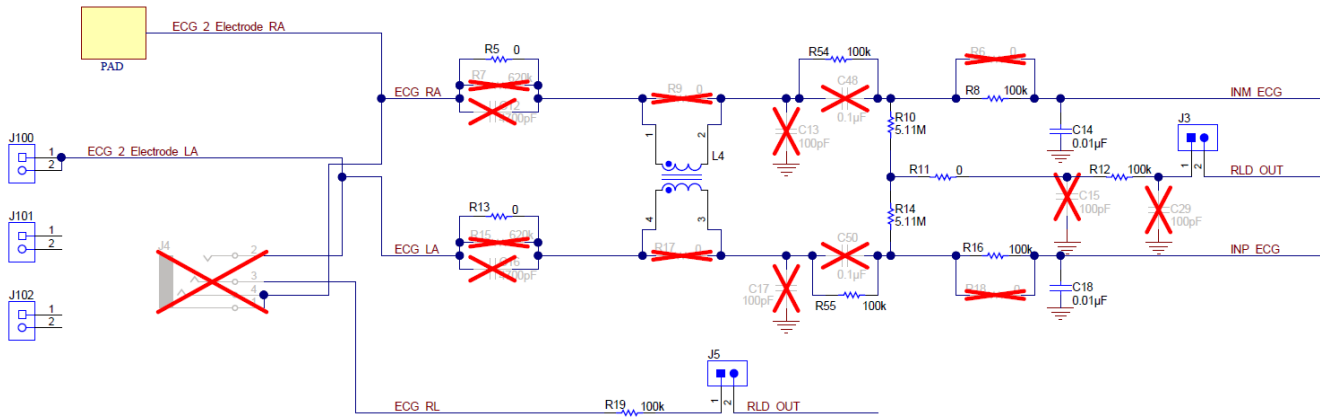

图 12. Interface for ECG Measurement (Three Electrodes)

表 4 lists the component mounting instructions for 2-electrode and 3-electrode configuration – for DC as well as AC lead-off detection. In both configurations, the series protection resistors and capacitors should be selected based on the low-pass filter cut-off requirement. The body connection should happen through 3-pin ECG cable via connector J4.

表 4. Component Mounting for Two-Electrode and Three-Electrode Configurations (DC and AC Lead-Off Detection)

CONFIG	J3	J4	J5	LOD ⁽¹⁾	R5	R7	C12	R13	R15	C16	R9	R17	L4	C13	C48	R54	C17	C50	R55	R10	R14	R11	R8	R6	R16	R18	C14	C18	R12	C15 & C29	
Three Es ⁽²⁾	DNM	M	M	AC	M	DNM	DNM	M	DNM	DNM	DNM	DNM	M	DNM	M	DNM	DNM	M	DNM	DNM	DNM	DNM	M	DNM	M	M	M	M	DNM	DNM	
				DC	M	DNM	DNM	M	DNM	DNM	DNM	DNM	DNM	DNM	M	M	DNM	M	M	DNM	M	DNM	DNM	DNM	M	DNM	M	DNM	M	M	M
Two Es	M	DNM	DNM	AC	M	DNM	DNM	M	DNM	DNM	DNM	DNM	M	DNM	M	DNM	DNM	M	DNM	M	M	M	DNM	M	DNM	M	M	M	M	DNM	DNM
				DC	M	DNM	DNM	M	DNM	NDNM	DNM	DNM	M	M	DNM	M	M	DNM	M	M	M	M	M	M	M	DNM	M	DNM	M	M	M

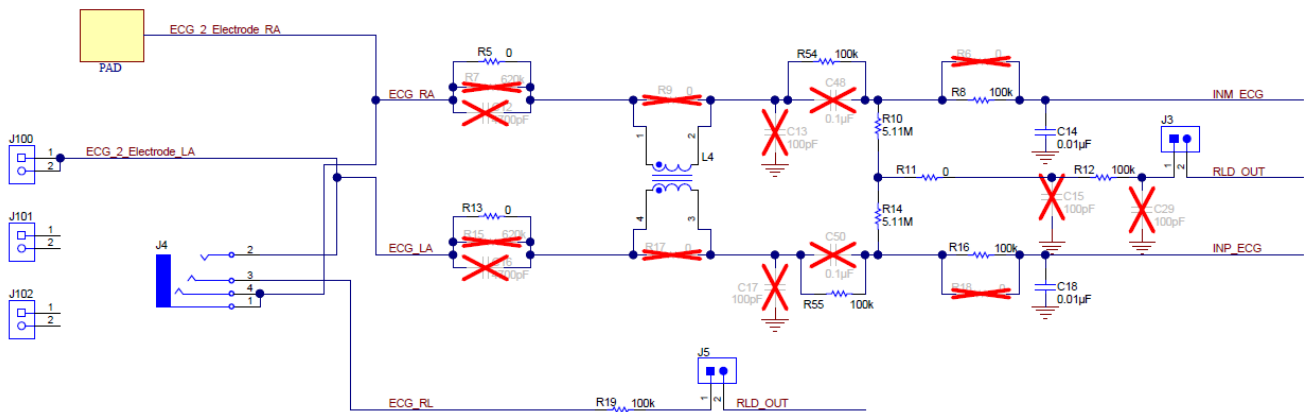
⁽¹⁾ Lead-Off Detection (LOD) type

⁽²⁾ Electrode (E)

2.3.5 Selecting TX Supply (TX_SUP) Value for Driving LEDs

表 5 shows the recommended TX_SUP voltage range, taken from the AFE4900 device data sheet.

表 5. Recommended TX_SUP Value

			MIN	MAX	UNIT	
RX_SU P	Receiver supply	LDO bypassed	1.8	1.9	V	
		LDO enabled	2.0	Minimum (3.6, TX_SUP)		
IO_SUP	I/O supply		1.7	RX_SUP	V	
TX_SUP	Transmitter supply	When operating at the maximum current setting	3.0 or $(0.3 + V_{HR} + V_{LED})^{(1)}$, whichever is greater		5.25	V
	Digital inputs		0	IO_SUP	V	
	Analog inputs		0	RX_SUP	V	
T _A	Operating temperature range		-20	70	°C	

⁽¹⁾ V_{LED} refers to the maximum voltage drop across the external LED (at maximum LED current). This value is usually governed by the forward drop voltage (V_{FB}) of the LED. V_{HR} refers to the headroom voltage of the LED driver as listed in 表 6 for various LED current settings. The extra 0.3 V is the suggested margin.

表 6 shows the headroom voltage, V_{HR} .

表 6. Headroom Voltages

ILED_FS REGISTER CONTROL	ONE LED DRIVER ON		TWO LED DRIVERS ON, THROUGH ONE LED		TWO LED DRIVERS ON, THROUGH TWO LEDs	
	FULL-SCALE CURRENT ⁽¹⁾	V_{HR} ⁽²⁾	FULL-SCALE CURRENT ⁽¹⁾	V_{HR} ⁽²⁾	FULL-SCALE CURRENT ⁽¹⁾	V_{HR} ⁽²⁾
0	50 mA	320 mV	100 mA	370 mV	50 mA	345 mV
1	100 mA	600 mV	200 mA	650 mV	100 mA	625 mV

⁽¹⁾ Full-scale current per LED.

⁽²⁾ Typical voltage headroom required for the LED driver.

$$TX_SUP = V_{LED} + V_{HR} + 0.3 = 3.2 + 0.625 + 0.3 = 4.125 \text{ V}$$

Select TX_SUP = 4.2 V.

2.3.6 Generating TX Supply for Driving LEDs

表 7. Specifications for TX_SUP

PARAMETER	VALUE
Input voltage	1.8 V to 3.0 V
Output voltage	4.2 V
Output current	50 mA
Output voltage ripple	±50 mV

2.3.6.1 Programming Output Voltage

The output voltage is programmed to 4.2 V using 公式 3, where $V_{REF} = 1.0 \text{ V}$. For best accuracy, the current following through R36 should be 100 times larger than the FB pin leakage current.

$$V_{OUT} = V_{REF} \times \frac{R35 + R36}{R36} \quad (3)$$

Because $V_{OUT} = 4.2 \text{ V}$ and $R36 = 100 \text{ k}\Omega$, $R35 = 320 \text{ k}\Omega$. TI recommends high-accuracy resistors for better output voltage accuracy. The TIDA-01580 device uses both resistors with 0.5% tolerance.

2.3.6.2 Maximum Output Current

The maximum output capability of the TPS61099 device is determined by the input-to-output ratio and the current limit of the boost converter.

公式 4 shows $I_{OUT(max)} = 300 \text{ mA}$ ($V_{IN} = 1.8 \text{ V}$, $I_{LIM} = 1 \text{ A}$, $I_{LH} = 350 \text{ mA}$, $\eta = 85\%$, and $V_{OUT} = 4.2 \text{ V}$).

$$I_{OUT(max)} = \frac{V_{IN} \times \left(I_{LIM} - \frac{I_{LH}}{2} \right) \times \eta}{V_{OUT}} \quad (4)$$

2.3.6.3 Input and Output Capacitor Selection

For the best output and input voltage filtering, TI recommends low-ESR X5R or X7R ceramic capacitors. The input capacitor minimizes input voltage ripple, suppresses input voltage spikes, and provides a stable system rail for the device. An input capacitor value of $10 \mu\text{F}$ (C47) is used to improve transient behavior of the regulator and EMI behavior of the total power supply circuit. TI recommends placing a ceramic capacitor as close as possible to the VIN and GND pins of the IC.

For the output capacitor of the VOUT pin, ceramic capacitors (C49 and C53) are placed as close as possible to the VOUT and GND pins of the IC. This capacitor must be placed as close as possible to the VOUT and GND pins of the IC. From the power-stage point of view, the output capacitor sets the corner frequency of the converter, while the inductor creates a Right-Half-Plane-Zero. Consequently, with a larger inductor, a larger output capacitor must be used. The TPS61099x device is optimized to work with the inductor from $1 \mu\text{H}$ to $2.2 \mu\text{H}$, so the minimal output capacitor value is $20 \mu\text{F}$ (nominal value). Increasing the output capacitor makes the output ripple smaller in PWM mode.

2.3.6.4 Switching Frequency

The switching frequency is calculated as 公式 5.

$$f = \frac{V_{IN} \times (V_{OUT} - V_{IN} \times \eta)}{L \times I_{LH} \times V_{OUT}} = \frac{1.8 \times (4.2 - 1.8 \times 0.85)}{2.2 \mu \times 0.35 \times 4.2} = 1.48 \text{ MHz} \quad (5)$$

图 13 shows the schematic for the boost converter, TPS61099.



图 13. TPS61099 Boost Converter ($V_{OUT} = 4.2 \text{ V}$)

2.3.6.5 WEBENCH® Simulation for TPS61099 Boost Converter

图 14 和 图 15 显示 WEBENCH® 仿真对于 TPS61099 升压转换器。对于任何自定义要求，仿真可在 [TPS61099 产品页面](#) 上可用。

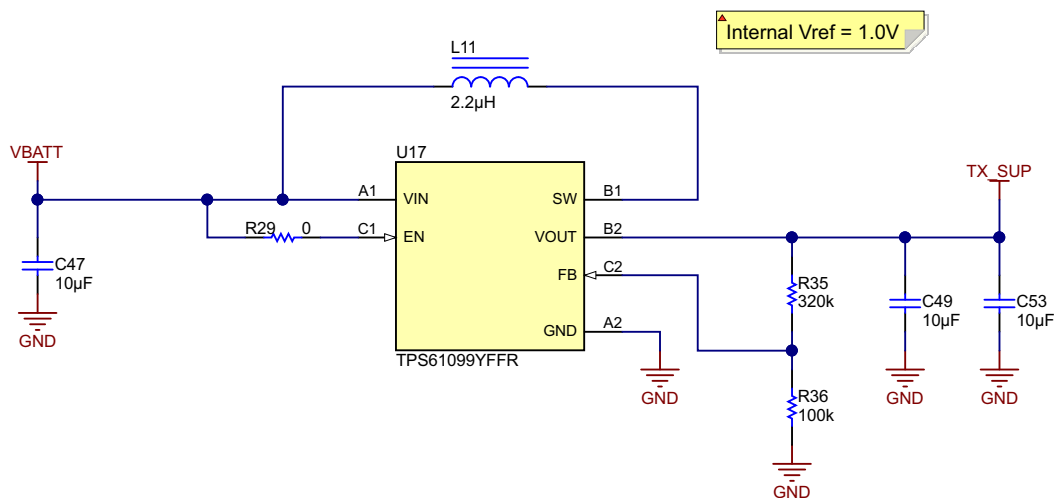

图 14. WEBENCH® Simulation for TPS61099 Boost Converter (Schematic)



图 15. WEBENCH® Simulation for TPS61099 Boost Converter (Test Results)

2.3.7 Generating RX Supply for AFE4900

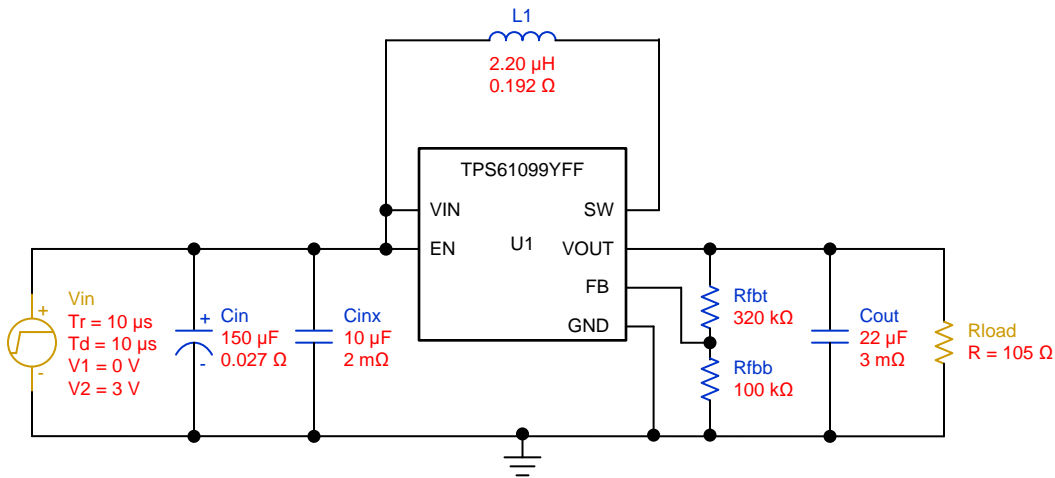
表 8. Specifications for RX_SUP

PARAMETER	VALUE
Input voltage	1.8 V to 3.0 V
Output voltage	2.1 V
Output current	10 mA
Output voltage ripple	±50 mV

2.3.7.1 Setting Output Voltage

The output voltage of the TPS63036 device is set by an external resistor divider connected between VOUT, FB, and GND. When the output voltage is regulated, the typical value of the voltage at the FB pin is 500 mV. The typical current into the FB pin is 0.01 μ A, and the voltage across the resistor between FB and GND, R32, is typically 500 mV. Based on these two values, the recommended value for R32 must be lower than 100 k Ω , to set the divider current at 5 μ A or higher (selected value of R32 = 51.1 k Ω). From here, the value of the resistor connected between VOUT and FB, R31, (depending on the needed VOUT), can be calculated using 公式 6.

$$R31 = R32 \times \left(\frac{V_{OUT}}{V_{FB}} - 1 \right) = 51.1k \times \left(\frac{2.1}{0.5} - 1 \right) = 163 k\Omega \quad (6)$$

A small capacitor C44 = 10 pF, in parallel with R31, is placed to considerably improve the output voltage ripple.

2.3.7.2 Capacitor Selection

TI recommends at least a 10- μ F input capacitor to improve transient behavior of the regulator and EMI behavior of the total power supply circuit. TI also recommends a ceramic capacitor be placed as close as possible to the VIN and GND pins of the IC (C43 = 10 μ F).

For the output capacitor, TI recommends using small ceramic capacitors placed as close as possible to the VOUT and GND pins of the IC. The recommended typical output capacitor value is 30 μ F. The TIDA-01580 device uses 10 μ F in parallel with 22 μ F. When choosing input and output capacitors, keep in mind that the value of capacitance experiences significant loss from its rated value, depending on the operating temperature and the operating DC voltage. It is not uncommon for a small surface-mount ceramic capacitor to lose 50% and more of its rated capacitance. For this reason it could be important to use a larger value of capacitance or a capacitor with higher voltage rating, to ensure the required capacitance at the full operating voltage.

2.3.7.3 Output Current Limit

表 9. Equations for Boost and Buck Mode in TPS63036

PARAMETER	BOOST MODE	BUCK MODE
Duty cycle	$D = \frac{V_{OUT} - V_{IN}}{V_{OUT}} = \frac{2.1 - 1.8}{2.1} = 0.143 \quad (7)$	$D = \frac{V_{OUT}}{V_{IN}} = \frac{2.1}{3} = 0.7 \quad (8)$

表 9. Equations for Boost and Buck Mode in TPS63036 (continued)

PARAMETER	BOOST MODE	BUCK MODE
Maximum output current	$I_{OUT} = \eta \times I_{SW} \times (1 - D)$ $I_{OUT} = 0.85 \times 1 \times (1 - 0.143)$ $I_{OUT} = 0.72845 \text{ A}$	$I_{OUT} = \frac{\eta \times I_{SW}}{D} = \frac{0.85 \times 1}{0.7} = 1.21 \text{ A}$

2.3.7.4 Inductor Selection

For high efficiency, the inductor must have a low DC resistance to minimize conduction losses. Especially at high-switching frequencies, the core material has a greater impact on efficiency. When using small chip inductors, efficiency is reduced mainly due to higher inductor core losses. This must be considered when selecting the appropriate inductor. The inductor value determines the inductor ripple current. The larger the inductor value, the smaller the inductor ripple current and the lower the conduction loss of the converter. Conversely, larger inductor values cause a slower load-transient response. The peak current for the inductor in steady-state operation can be calculated to avoid saturation of the inductor with the chosen inductance value. The equation which defines the switch current in boost mode is reported, because it provides the highest value of current and represents the critical current value for selecting the right inductor.

$$I_{PEAK} = I_{SW_MAX} + \frac{V_{IN} \times D}{2 \times f \times L} = 1 + \frac{1.8 \times 0.143}{2 \times 2 \text{ M} \times 1 \mu} = 1.06435 \text{ A}$$

where

- D = Duty cycle in boost mode
- F = converter switching frequency (typical 2 MHz)
- L = Selected inductor value
- H = Estimated converter efficiency
- I_{SW_MAX} = Maximum average input current

(11)

图 16 shows the schematic for the buck-boost converter, TPS63036.



图 16. TPS63036 Buck-Boost Converter ($V_{OUT} = 2.1 \text{ V}$)

2.3.7.5 TINA-TI™ Simulation for TPS63036

图 17 和 图 18 显示 TINA-TI™ 仿真对于 TPS63036 升降压转换器。TINA 仿真文件对于任何自定义要求可以从 [TPS63036 产品页](#) 下载。

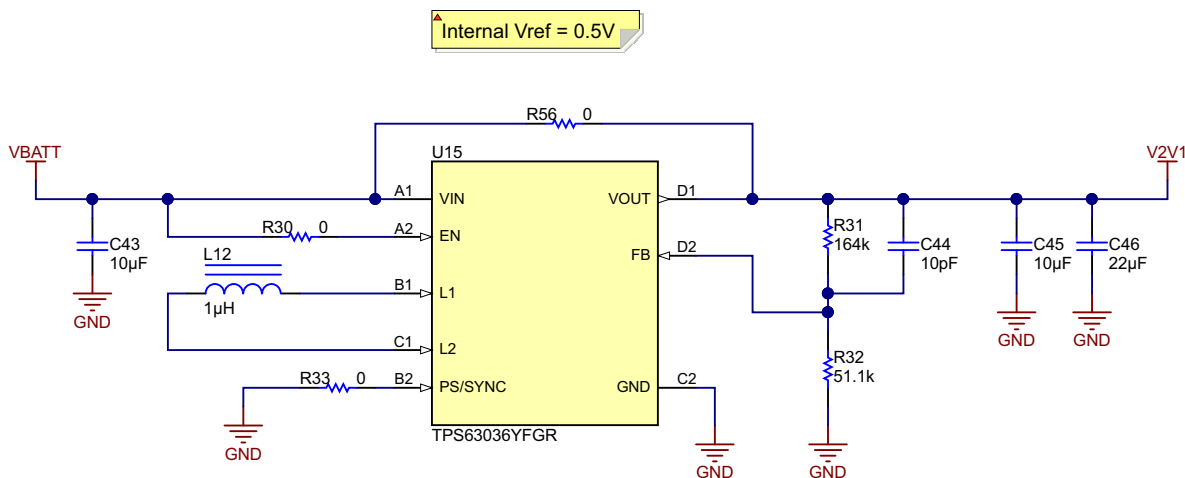

图 17. TINA-TI™ Simulation for TPS61099 Boost Converter (Schematic)



图 18. TINA-TI™ Simulation for TPS61099 Boost Converter (Test Results)

2.3.8 Generating I/O Supply

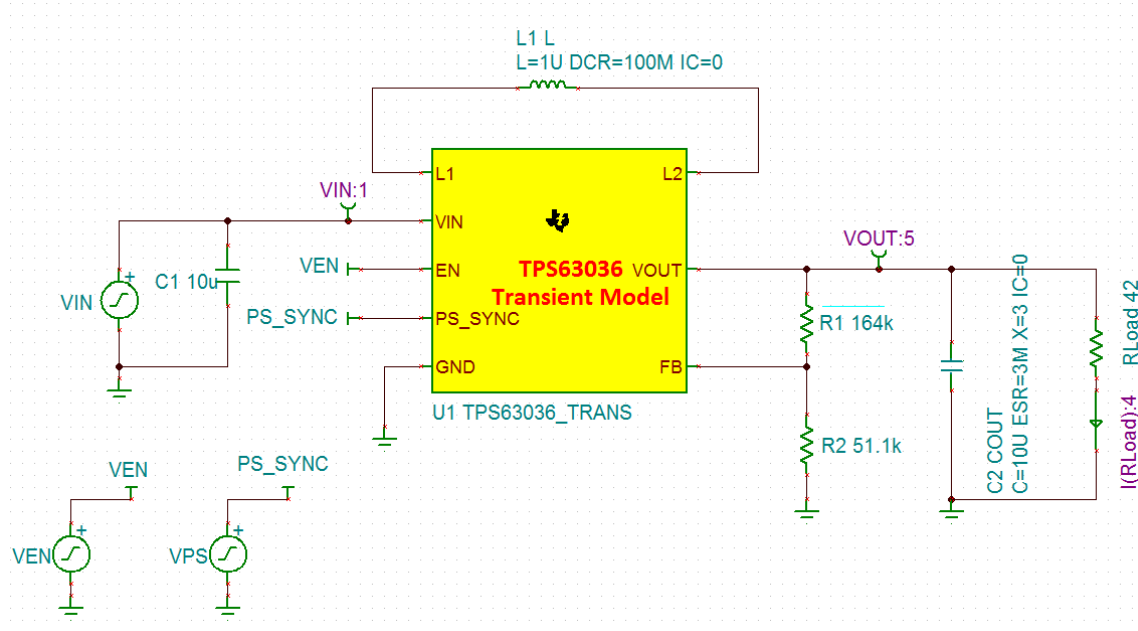
The I/O supply selected is the same as RX-SUP (2.1 V) through R28 (0Ω). There is an option to mount an LDO at position U18 though.

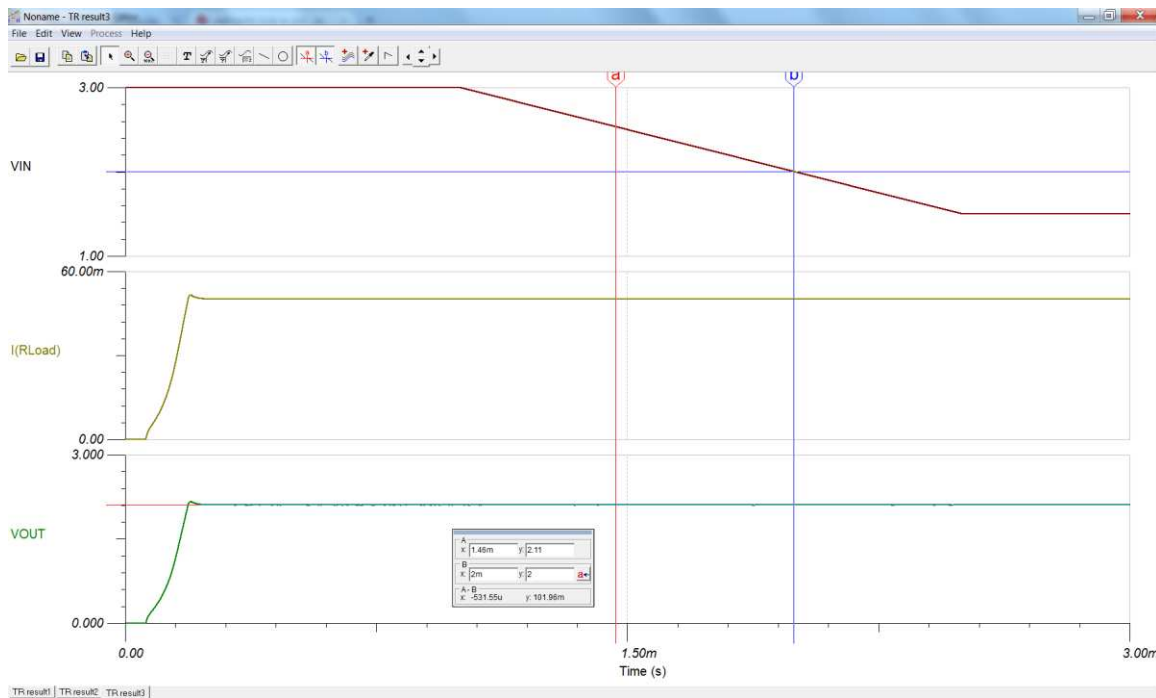

图 19. IO_SUP Same as RX_SUP

注: U18 is currently not mounted on the TIDA-01580 board. The user can mount U18 if IO_SUP must be different than 2.1 V. LDOs with low drop-out voltages (for example, < 300 mV) have higher quiescent currents – which may affect the battery operating time.

2.3.9 Battery Input and Reservoir Capacitors

The power source for this TIDA-01580 device is the CR3032, a lithium-ion coin cell. Selection of the CR2032 coin-cell battery as the power source was due to the ubiquity of the battery type, particularly in small form factor systems. The voltage characteristics of the CR3032 lithium-ion coin cell battery are also ideal. The output voltage remains relatively flat throughout the discharge life, until the cell is nearly depleted. When the remaining charge in the coin-cell battery is nearly depleted, the output voltage drops off relatively quickly. The temperature characteristics of lithium-ion batteries are also superior to that of alkaline cells, particularly at lower temperatures. This superiority is due to lithium-ion cells having a non-aqueous electrolyte that performs better than the aqueous electrolytes commonly found in alkaline batteries.

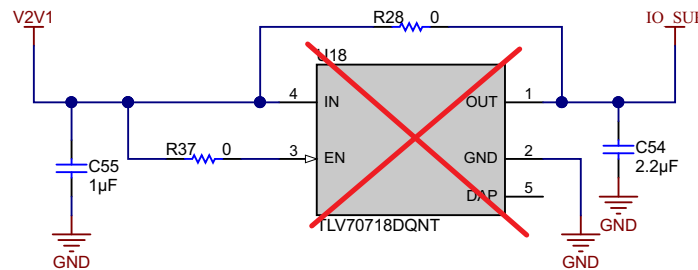

图 20. Battery Connector and Reservoir

Given an appropriate weather-proof enclosure, this TI reference design system is suited for both indoor and outdoor use. Immediately following the battery is a bulk capacitor. This TI reference design uses a coin-cell battery tray that prevents an end-user from inserting the battery backwards, which may eliminate the need for the reverse Schottky diode. The bulk capacitor is sized to prevent too much voltage sag, particularly during the initial transition into the on state (see 图 20).

2.3.10 Battery Life Calculations

This section explains the calculations for battery life of the CR3032 coin-cell battery. The possible current paths in this design are:

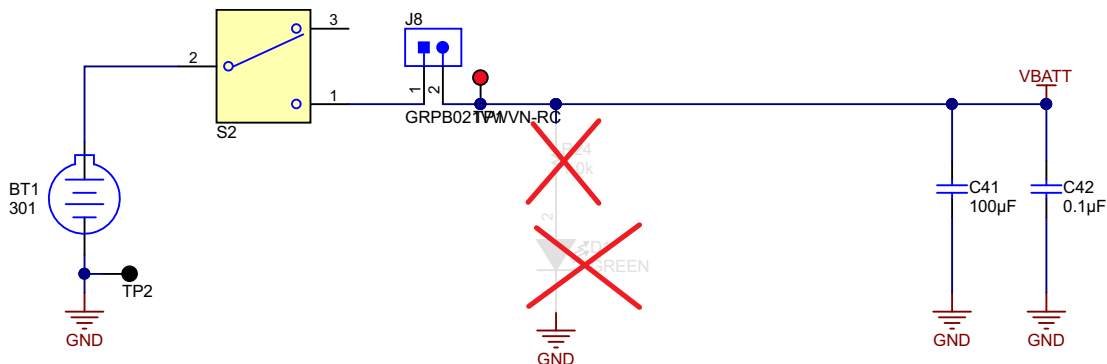
- Battery to AFE4900, through the Boost (TPS61099) to the TX_SUP pin
- Battery to AFE4900, through the Buck-Boost (TPS63036) to the RX_SUP/IO_SUP pin
- Battery to CC2640R2F, through the Buck-Boost (TPS63036) to the VDDS2/3 pin
- Battery to CC2640R2F, directly to the VDDS pin

2.3.10.1 AFE4900 Current Consumption

The current consumption of the AFE4900 device depends on the sampling rate (for example, PTT mode at 1-kHz sampling rate for both ECG and PPG).

Typical specifications are at $T_A = 25^\circ\text{C}$; TX_SUP = 5 V, RX_SUP = 1.8 V (with CONTROL1 = 1.8 V to bypass internal LDOs), IO_SUP = 1.8 V, external clock mode with 32-kHz clock on CLK pin (period = $t_{TE} = 31.25 \mu\text{s}$), the AFE operates with ULP mode enabled (ENABLE_ULP = 1); **PPG**: 1-kHz sampling rate, SAMP width of $3 \times t_{TE}$, LED ON width of $4 \times t_{TE}$, C_F chosen such that there are 7-8 TIA time constants within the SAMP width, NUMAV = 1 (2 ADC averages), noise-reduction filter bandwidth set to 2.5 kHz, $C_{IN} = 100 \text{ pF}$ (capacitor across the input pins to model the zero bias differential capacitance of the PD); **ECG**: 1-kHz sampling rate, INA gain of 12, chopper mode enabled (unless otherwise noted).

表 10. Current Consumption for AFE4900 in Different Modes

PARAMETER	TEST CONDITIONS	MIN	TYP	MAX	UNIT
CURRENT CONSUMPTION					

表 10. Current Consumption for AFE4900 in Different Modes (continued)

PARAMETER	TEST CONDITIONS	MIN	TYP	MAX	UNIT
RX_SUP current excluding switching current from I ² C or SPI readout ⁽¹⁾	Low PRF PPG signal acquisition ⁽²⁾		50		μA
	High PRF ECG, PPG signal acquisition ⁽³⁾		600		
	Hardware power-down (PWDN) mode ⁽⁴⁾		< 1		
	Software power-down (PDNAFE) mode ⁽⁴⁾		15		
RX_SUP current resulting from switching current at I ² C readout	At PRF of 50 Hz, readout with FIFO enabled with FIFO_PERIOD = 60, FIFO_NPHASE = 4 ⁽⁵⁾		6		μA
	Power-down mode		0		
IO_SUP current	Low PRF, PPG signal acquisition ⁽²⁾		1		μA
	High PRF, ECG, PPG signal acquisition ⁽²⁾		1		
	Hardware power-down (PWDN) mode ⁽⁴⁾		< 1		
	Software power-down (PDNAFE) mode ⁽⁴⁾		< 1		
TX_SUP current	Low PRF, PPG signal acquisition ⁽²⁾		4		μA
	High PRF, ECG, PPG signal acquisition ⁽³⁾		20		
	Hardware power-down (PWDN) mode ⁽⁴⁾⁽⁶⁾		< 1		
	Software power-down (PDNAFE) mode ⁽⁴⁾⁽⁶⁾		< 1		
DIGITAL INPUTS					
V _{IH} High-level input voltage	Digital inputs except CONTROL1, I2C_SPI_SEL	0.9 × IO_SUP	IO_SUP		V
	CONTROL1 and I2C_SPI_SEL ⁽⁷⁾	0.85 × RX_SUP	RX_SUP		
V _{IL} Low-level input voltage	Digital inputs except CONTROL1, I2C_SPI_SEL		0	0.1 × IO_SUP	V
	CONTROL1 and I2C_SPI_SEL ⁽⁷⁾		0	0.1 × RX_SUP	
DIGITAL OUTPUTS					
V _{OH} High-level output voltage			IO_SUP		V
V _{OL} Low-level output voltage			0		V

- (1) The additional current for FIFO readout is negligible when operating in the SPI mode.
- (2) Acquisition of four phases of signal in PPG mode at 50-Hz PRF.
- (3) PTT mode at 1-kHz sampling rate for both ECG and PPG
- (4) External clock switched off.
- (5) This current depends on the percentage of time for which the I2C_CLK is low; and scales with FIFO_NPHASE and PRF. This extra component of current is negligible when operating in the SPI interface mode.
- (6) With LED currents set to 0 mA
- (7) CONTROL1 and I2C_SPI_SEL can also be driven directly by the MCU (with IO_SUP levels) if the V_{IH}, V_{IL} levels are satisfied.



图 21. Current Consumption for AFE4900 in LDO Enable Mode

The TX_SUP current is taken to be 3 mA at normal operating conditions (10% duty cycle for 100 mA) – worst case.

Over operating free-air temperature range (unless otherwise noted).

表 11. LED Drive Currents With Duty Cycles

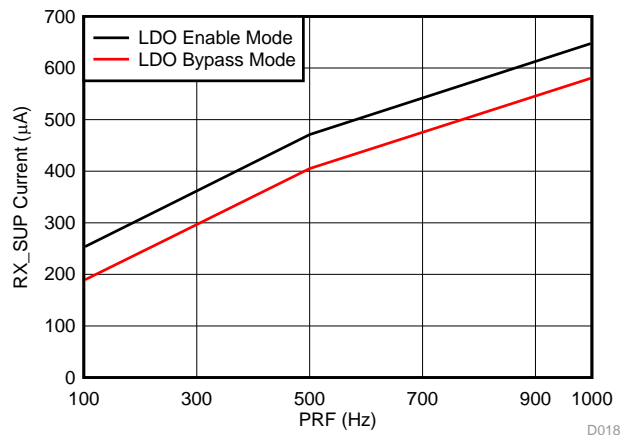
PARAMETER ⁽¹⁾⁽²⁾		MIN	MAX	UNIT
Supply voltage range	RX_SUP to GND LDO bypassed	-0.3	2.1	V
	RX_SUP to GND LDO enabled ⁽³⁾	-0.3	4	
	IO_SUP to GND	-0.3	Min [4,(RX_SUP+0.3)]	
	TX_SUP to GND	-0.3	6	
Voltage applied to analog inputs		Max [-0.3, (GND - 0.3)]	Min [4.0, (RX_SUP + 0.3)]	V
Voltage applied to digital inputs		Max [-0.3, (GND - 0.3)]	Min [4.0, (IO_SUP + 0.3)]	V
Maximum duty cycle (cumulative): sum of all LED phase durations as a function of the total period	50-mA LED current		10%	
	100-mA LED current		3%	
	200-mA LED current		1%	
Junction temperature, T _J			105	°C
Storage temperature, T _{stg}		-60	150	°C

⁽¹⁾ Stresses beyond those listed under *Absolute Maximum Ratings* may cause permanent damage to the device. These are stress ratings only, which do not imply functional operation of the device at these or any other conditions beyond those indicated under *Recommended Operating Conditions*. Exposure to absolute-maximum-rated conditions for extended periods may affect device reliability.

⁽²⁾ If subjected to additional processing steps (for example during PCB assembly or product manufacturing), avoid exposure of the device to UV radiation and exposure to high temperatures (350°C and higher).

⁽³⁾ Voltages higher than 2.1 V can be applied on RX_SUP only when CONTROL1 pin is at 0.

The RX_SUP and IO_SUP current are taken to be 700 μA (600 μA + 10 μA (I/O) + 50 μA (LDO enabled) + 40 μA (buffer)).

2.3.10.2 CC2640R2F Current Consumption

The net total of the current supplied to the CC2640R2F device is taken as 10 mA (including peripherals and TX only). A 50- μ A average current is chosen at V_{DDS}/3.

Measured on the TI CC2650EM-5XD reference design with T_c = 25°C, V_{DDS} = 3.0 V with an internal DC/DC converter, unless otherwise noted.

表 12. Power Consumption for CC2640R2F

PARAMETER		TEST CONDITIONS	MIN	TYP	MAX	UNIT
I _{core}	Core current consumption	Reset. RESET_N pin asserted or V _{DDS} below Power-on-Reset threshold		100		nA
		Shutdown. No clocks running, no retention		150		
		Standby. With RTC, CPU, RAM and (partial) register retention. RCOSC_LF		1.1		μ A
		Standby. With RTC, CPU, RAM and (partial) register retention. XOSC_LF		1.3		
		Standby. With Cache, RTC, CPU, RAM and (partial) register retention. RCOSC_LF		2.8		
		Standby. With Cache, RTC, CPU, RAM and (partial) register retention. XOSC_LF		3.0		
		Idle. Supply Systems and RAM powered.		550		
		Active. Core running CoreMark		1.45 mA + 31 μ A/MHz		
		Radio RX ⁽¹⁾		5.9		mA
		Radio RX ⁽²⁾		6.1		
		Radio TX, 0-dBm output power ⁽¹⁾		6.1		
Radio TX, 5-dBm output power ⁽²⁾		9.1				
Peripheral Current Consumption (Adds to core current I_{core} for each peripheral unit activated) ⁽³⁾						
I _{peri}	Peripheral power domain	Delta current with domain enabled		20		μ A
	Serial power domain	Delta current with domain enabled		13		μ A
	RF Core	Delta current with power domain enabled, clock enabled, RF core idle		237		μ A
	μ DMA	Delta current with clock enabled, module idle		130		μ A
	Timers	Delta current with clock enabled, module idle		113		μ A
	I ² C	Delta current with clock enabled, module idle		12		μ A
	I2S	Delta current with clock enabled, module idle		36		μ A
	SSI	Delta current with clock enabled, module idle		93		μ A
UART	Delta current with clock enabled, module idle		164		μ A	

⁽¹⁾ Single-ended RF mode is optimized for size and power consumption. Measured on CC2650EM-4XS.

⁽²⁾ Differential RF mode is optimized for RF performance. Measured on CC2650EM-5XD.

⁽³⁾ I_{peri} is not supported in Standby or Shutdown.

2.3.10.3 On-State Current Calculations

Now, the reflected current on the input side of the TPS61099 device is given in 公式 12.

$$I_{\text{TPS61098}} = \frac{V_O \times I_O}{(V_{\text{imin}} \times \eta)} = \frac{4.2 \times 3 \text{ mA}}{(1.8 \times 0.85)} = 8.5 \text{ mA} \quad (12)$$

Where, efficiency is taken to be 85% (max 88% at low load of 10 μA), see 公式 13.

$$I_{\text{TPS63036}} = \frac{V_O \times I_O}{(V_{\text{imin}} \times \eta)} = \frac{2.1 \times 750 \mu\text{A}}{(1.8 \times 0.9)} = 975 \mu\text{A} = 1 \text{ mA} \quad (13)$$

Where efficiency is taken to be 50%. Therefore, the net total current from all the branch is given in 公式 14.

$$I_{\text{net}} = 8.5 \text{ mA} + 1 \text{ mA} + 12 \text{ mA} = 21.5 \text{ mA} \quad (14)$$

Therefore, the calculated battery life of the coin cell is given in 公式 15.

For CR3032, rating = 500 mAh

$$\text{Life(hrs)} = 500 \frac{\text{mAh}}{21.5 \text{ mA}} \times 0.85 = 19.76 \text{ hrs} \quad (15)$$

The measured currents on the TIDA-01580 device are much less than these calculated values, because the calculations are for worst-case performance. The measured values are follow.

$$I_{\text{net}} = 4.09 \text{ mA at } V_{\text{in}} = 3 \text{ V}$$

$$I_{\text{net}} = 6.05 \text{ mA at } V_{\text{in}} = 1.8 \text{ V}$$

So $I_{\text{avg}} = 5.06 \text{ mA}$, which gives battery life of 98.7 hours.

2.3.10.4 Off-State Current Calculations (Considering Battery Voltage = 3 V)

The RX_SUP current at low-power operation (15 μA at software power-down mode and 1 μA at hardware power-down mode) = 16 μA (worst case). The TX_SUP current at low-power operation (1 μA at software power-down mode, 1 μA at hardware power-down mode) = 2 μA (worst case). The net total current supplied to the CC2640R2F device is taken as 200 nA (shutdown), 5 μA (standby), and 550 μA (idle).

Now, reflected current on the input side of TPS61099 is

$$I_{\text{TPS61098}} = \frac{V_O \times I_O}{(V_{\text{imin}} \times \eta)} = \frac{4.2 \times 2 \mu\text{A}}{(1.8 \times 0.85)} = 5.62 \mu\text{A} \quad (16)$$

$$I_{\text{TPS63036}} = \frac{V_O \times I_O}{(V_{\text{imin}} \times \eta)} = \frac{2.1 \times 16 \mu\text{A}}{(1.8 \times 0.85)} = 22 \mu\text{A} \quad (17)$$

$$I_{\text{net(shutdown)}} = 5.62 \mu\text{A} + 22 \mu\text{A} + 0.2 \mu\text{A} = 27.82 \mu\text{A} \quad (18)$$

$$I_{\text{net(standby)}} = 5.62 \mu\text{A} + 22 \mu\text{A} + 5 \mu\text{A} = 32.62 \mu\text{A} \quad (19)$$

$$I_{\text{net(idle)}} = 5.62 \mu\text{A} + 22 \mu\text{A} + 600 \mu\text{A} = 627.62 \mu\text{A} \quad (20)$$

表 13 lists the battery lifetime for the cases shown.

表 13. Battery Life Calculations

MODE	ON-STATE CURRENT (mA)	OFF-STATE CURRENT (μ A)	BATTERY LIFE FOR 1 s/MIN DUTY CYCLE (DAYS)	BATTERY LIFE FOR 5 s/MIN DUTY CYCLE (DAYS)	BATTERY LIFE FOR 20 s/MIN DUTY CYCLE (DAYS)
Shutdown	4.09	25	224	57	15
Standby	4.09	30	213	56	15
Idle	4.09	625	30	23	11.7

2.3.11 External Memory

注: U16 is currently not mounted on the TIDA-01580 board. The user can mount it if external-data log memory is required. When selecting the memory, the user must check the IO_SUP value and operating VCC for the memory.

The TIDA-01580 board has a provision for external memory connection over SPI, as shown in 图 22.



图 22. External Memory

表 14 lists the connections between the memory chip and the CC2640R2F device.

表 14. Connections Between Memory and CC2640R2F

MEMORY PIN NUMBER	FUNCTION	CC2640R2F PIN NUMBER	FUNCTION	COMMENTS
1	/CS	18	DIO_12	Memory SPI enable
2	D0 (IO1)	15	DIO_9	SPI OUT for memory
3	/WP (IO2)	19	DIO_13	Memory write protect
5	D1 (IO0)	14	DIO_8	SPI IN for memory
6	CLK	16	DIO_10	SPI CLK for memory
7	/HOLD or /RESET	20	DIO_14	Memory hold

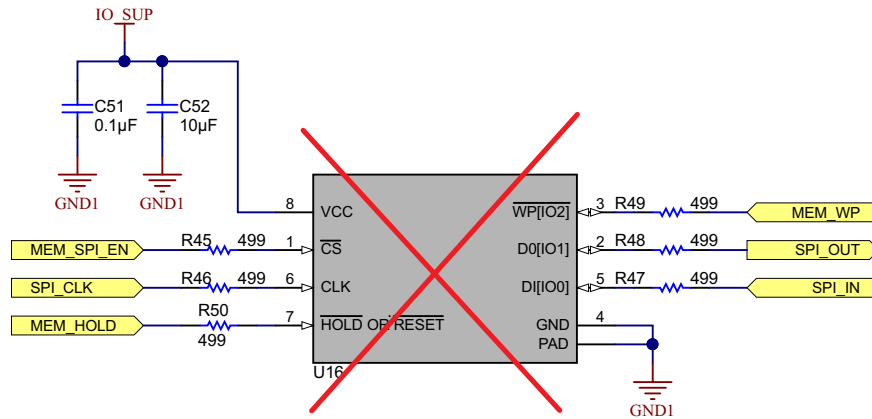
2.3.12 LED Indications

The board has four LEDs for indication, see 图 23 and 图 20.



图 23. LED Indications

表 15 lists the functions of each LED.

表 15. LED Indications

LED NUMBER	COLOR	FUNCTION
D1	Green	Incoming power supply or battery indicator
D2	Red	Lead-off detection
D3	Red	Low-battery indication
D4	Red	BLE connection status

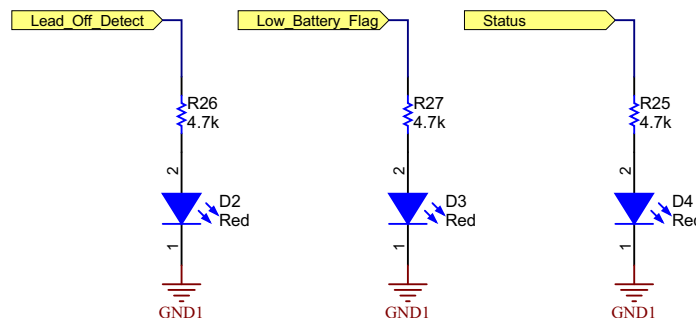
2.3.13 Connections Between Sensor Board and ECG Board

图 24 shows the connectors which connect all the boards together. The J1, J2, J3, J1_M, and J2_M connectors are used for connecting the ECG board to the main board. The J1_S and J2_S connectors are used for connecting the PPG sensor boards.



图 24. Connections Between Sensor Board and ECG Board

3 Hardware, Software, Testing Requirements, and Test Results

3.1 Required Hardware and Software

3.1.1 Hardware

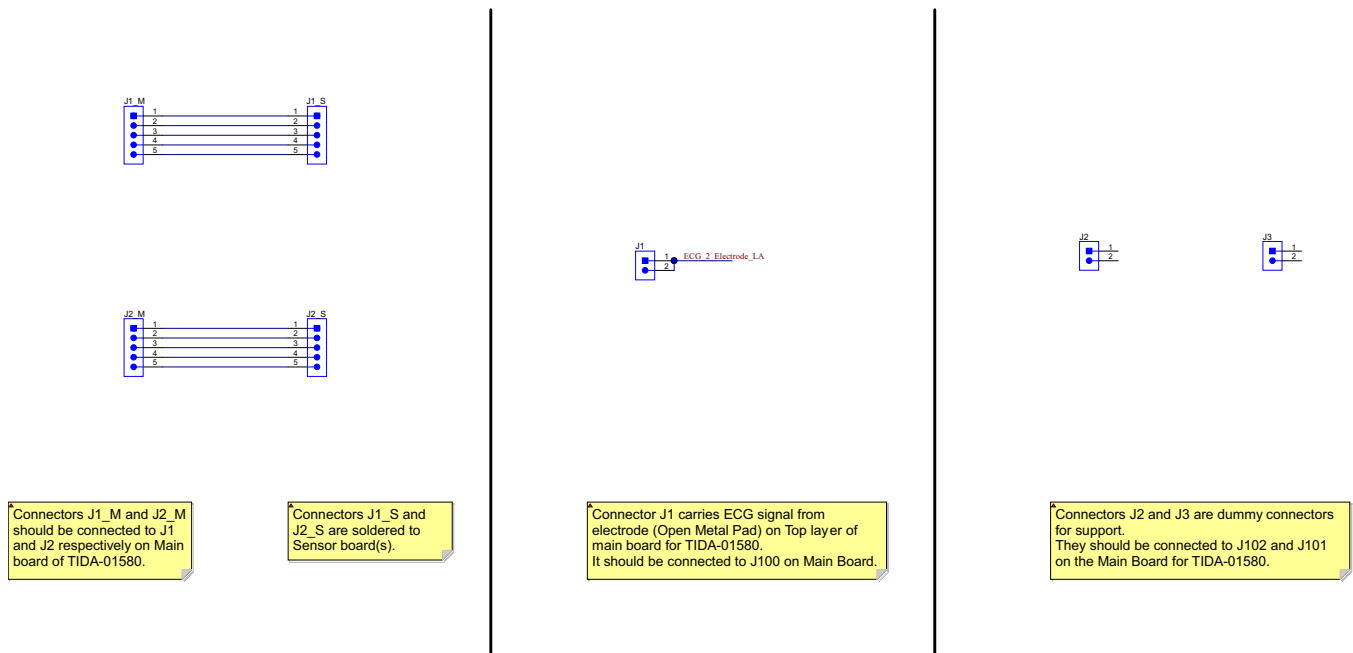
图 25 和 图 26 显示 TIDA-01352 PCB 的顶部和底部视图，分别。重要的部分用红色方框和标题突出显示。



图 25. TIDA-01580 PCB - Top View
Battery Holder (BT1) Not Mounted



图 26. TIDA-01580 PCB - Bottom View

3.1.1.1 Connecting Optical Sensor and ECG Boards to Main Board

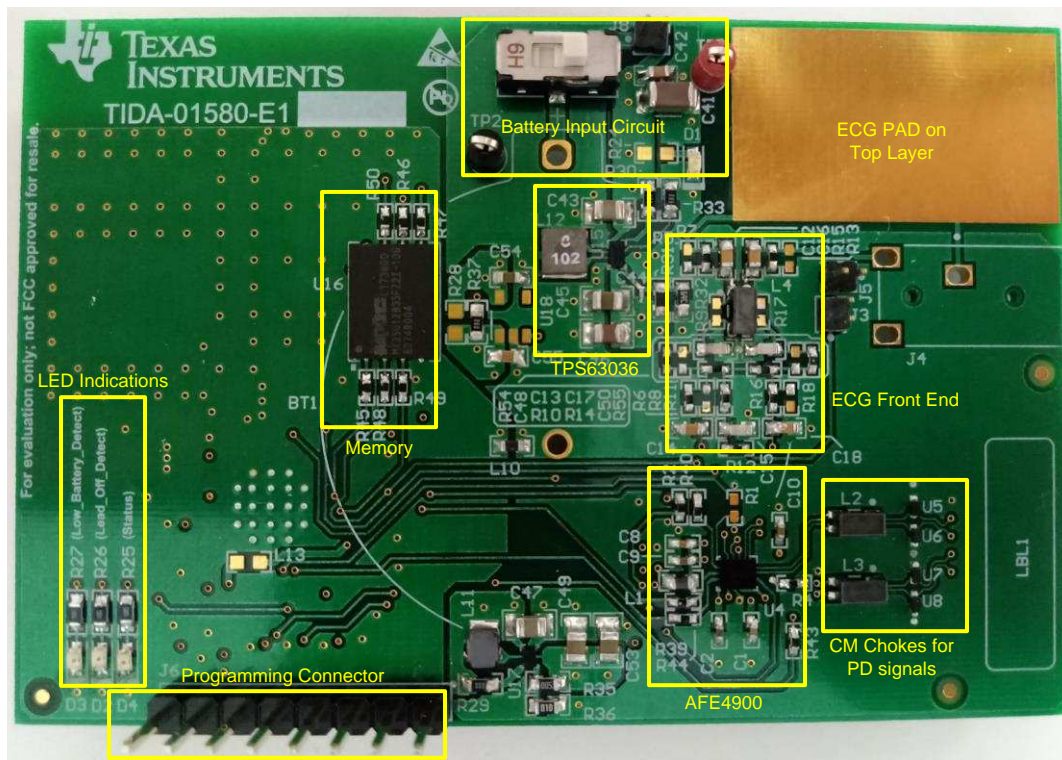
图 27 shows the ECG and PPG board mounted on the main board.

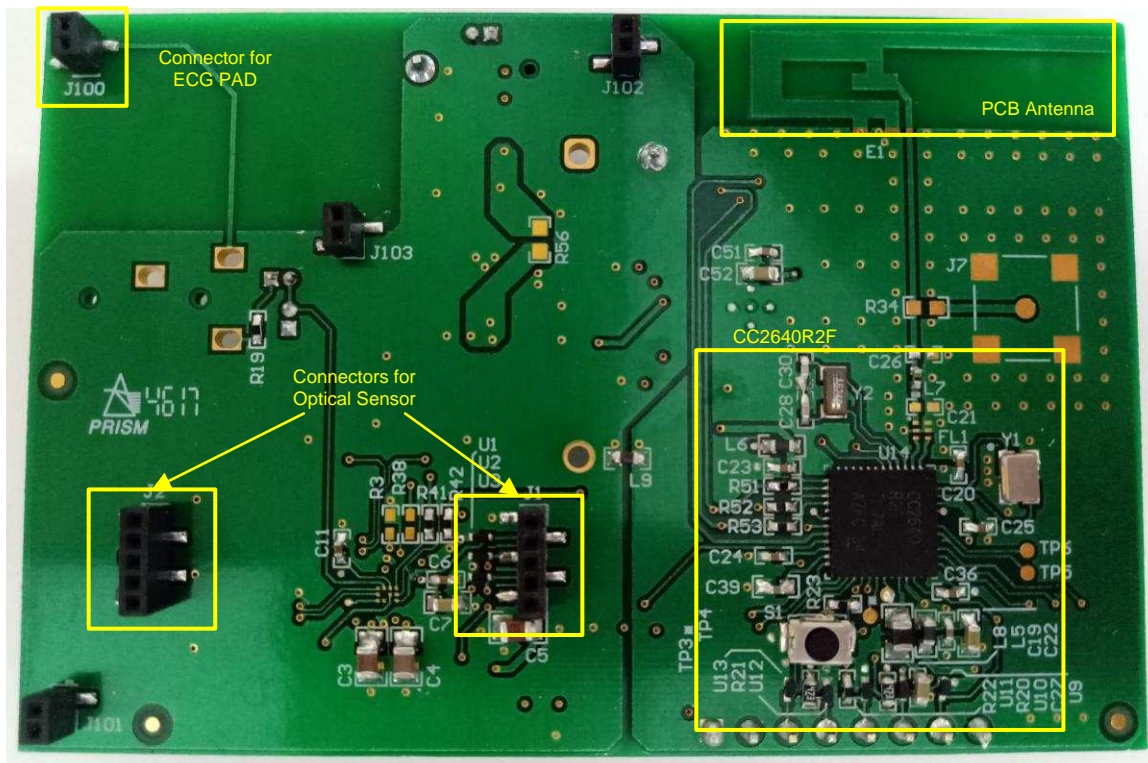

图 27. ECG and PPG Board Mounted on Main Board (Top View)

图 28 shows separate PPG and ECG boards. The PPG board must be soldered on the ECG board in such a way that the PPG sensor faces towards the cut-slot on the ECG board.



图 28. Separate PPG and ECG Boards

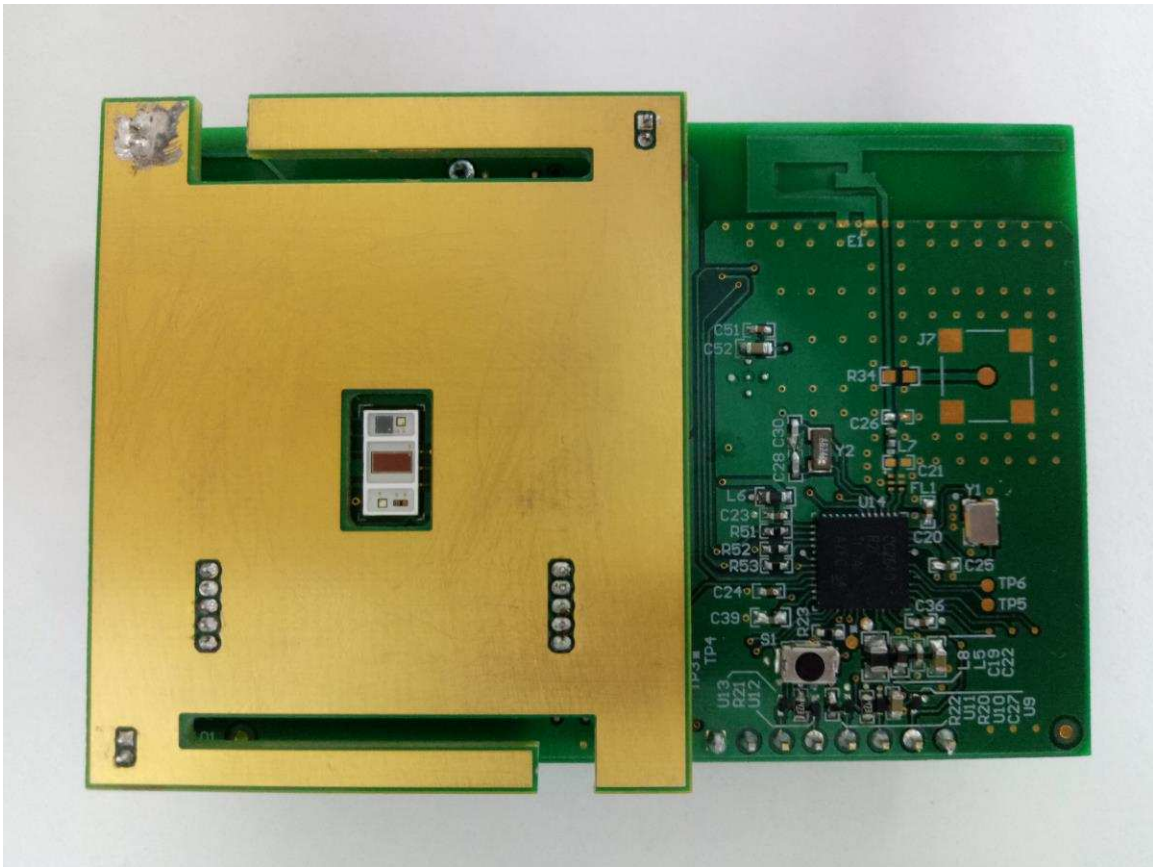

图 29. ECG and PPG Board

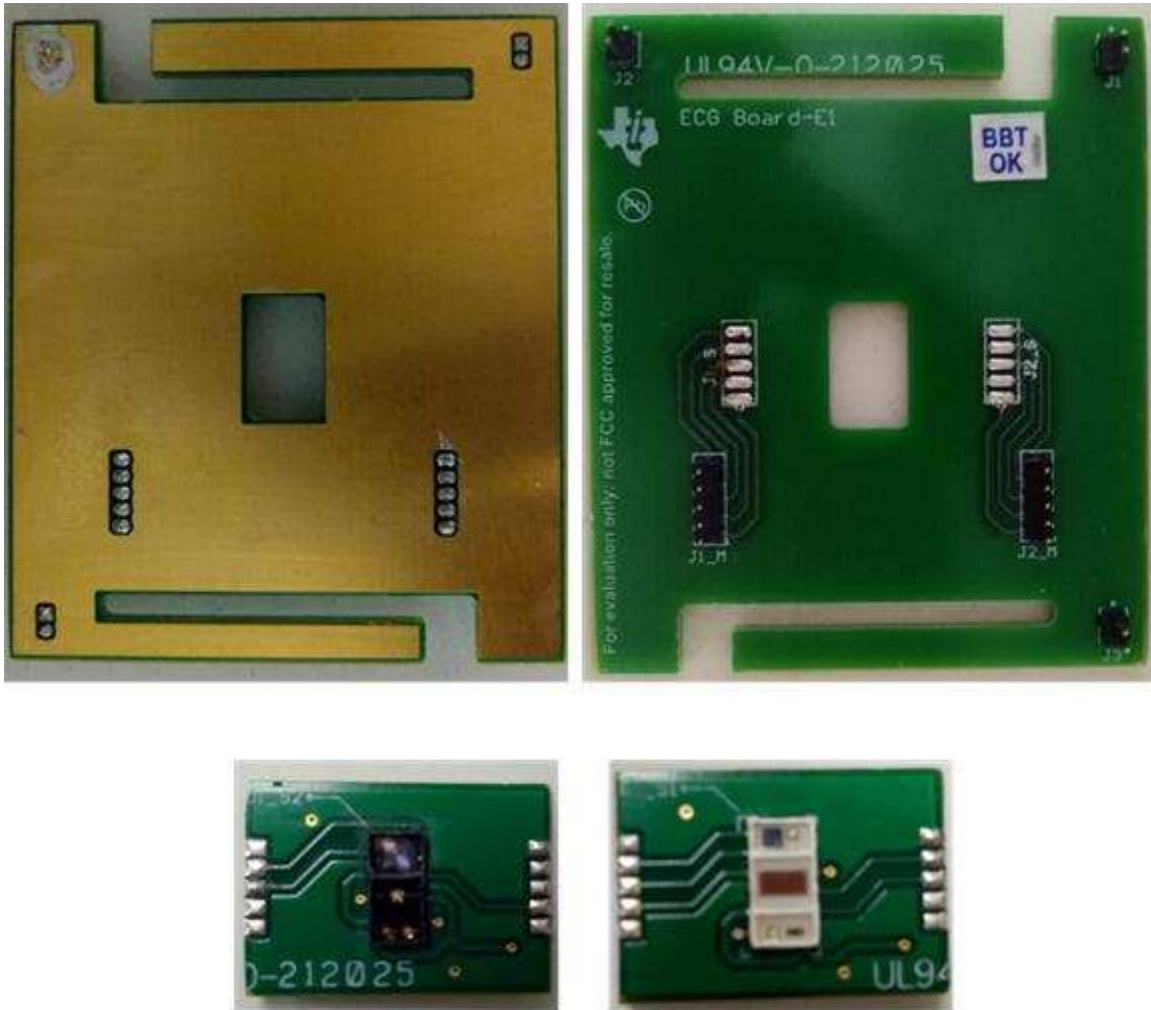

图 30. ECG and PPG Board Mounted on Main Board (Side View)

3.1.1.2 Difference Between PPG Sensor Boards

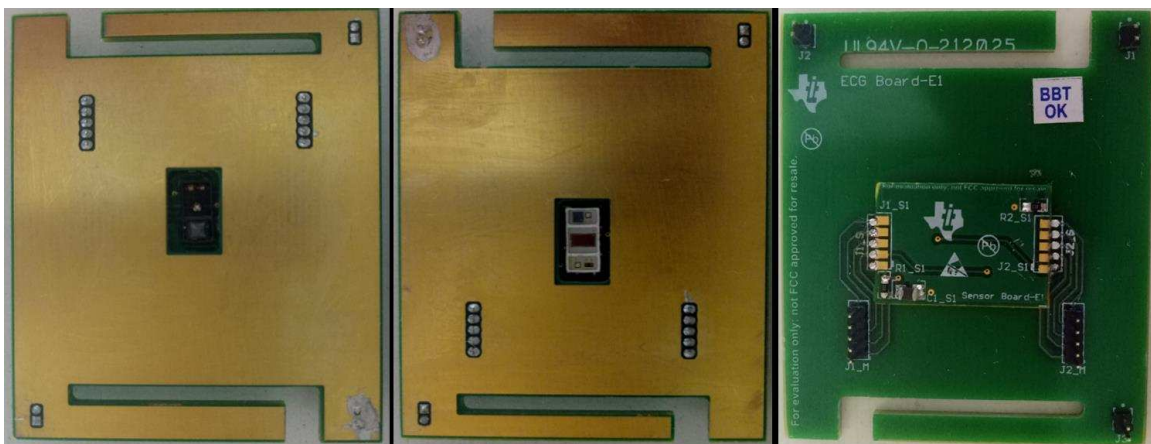
One PPG sensor board uses the SFH 7072 device from OSRAM. The default configuration for the PPG sensor board follows:

- LED1 (green1) of the SFH7072 = connected to TX4 of the AFE4900 device
- LED2 (green2) of the SFH7072 = not connected to the AFE4900 device
- LED3 (red) of the SFH7072 = connected to TX2 of the AFE4900 device
- LED4 (IR) of the SFH7072 = connected to TX3 of the AFE4900 device
- The Dual_PD_Enable bit is set in the 0x4E register in the AFE4900 device (see [图 31](#)).
- PD1 of the AFE4900 device is connected to Broadband PD, and PD2 of the AFE4900 device is connected to Infrared-Cut PD.

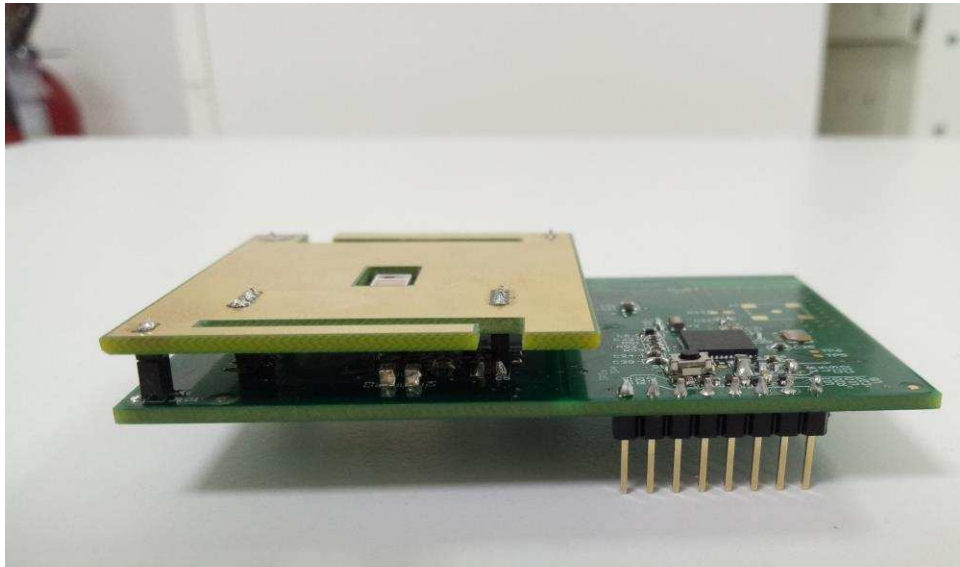
Registers to be read for getting raw data follow:

- 0x2A – Raw PPG data from the red LED
- 0x2B – Raw PPG data from the IR LED
- 0x2C – Raw PPG data from the green LED
- 0x2D – Raw ECG data



图 31. Timing and Settings for SFH 7072 PPG Sensor

The other PPG sensor board uses the OCS112 device from tBPC. The default configuration for the PPG sensor board follows:

- LED1 (red) of the OCS112 device = connected to TX2 of the AFE4900 device
- LED2 (IR) of the OCS112 device = connected to TX3 of the AFE4900 device
- LED3 (green) of the OCS112 device = connected to TX4 of the AFE4900 device

Because this sensor has only one PD, the Dual_PD_Enable bit is not set in the 0x4E register in the AFE4900 device (see 图 32). PD1 of the AFE4900 device is always connected to PD of the sensor.

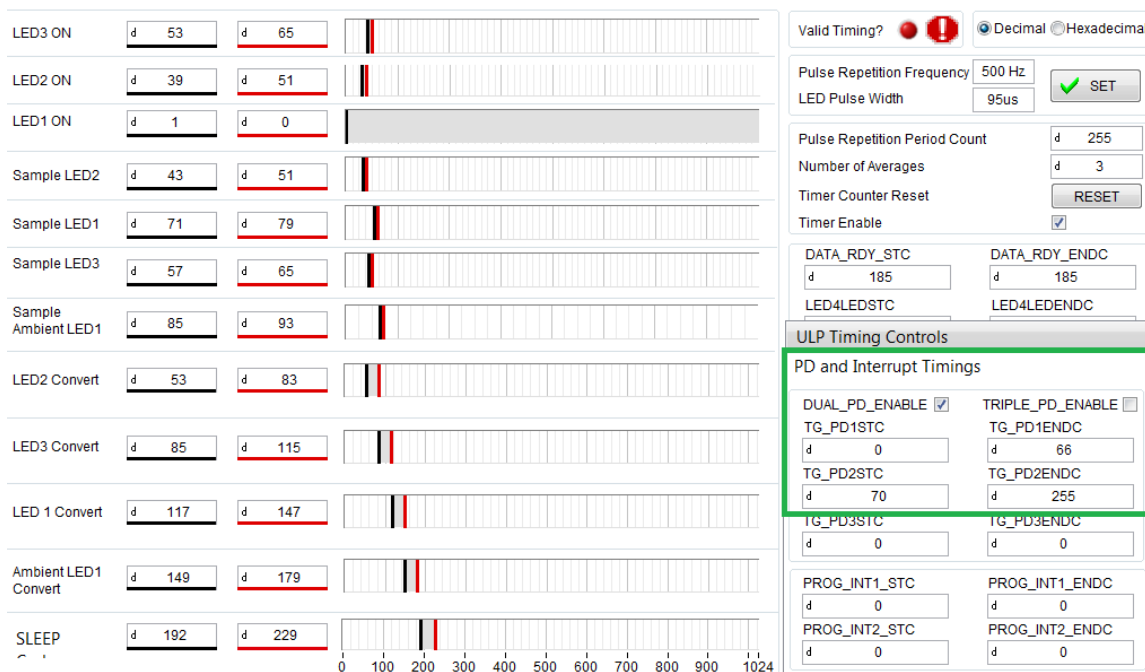
Registers to be read for getting raw data follow:

- 0x2A – Raw PPG data from the red LED
- 0x2B – Raw PPG data from the IR LED
- 0x2C – Raw PPG data from the green LED
- 0x2D - Raw ECG data



图 32. Timing and Settings for OCS112 PPG Sensor

注: 图 31 和 图 32 是 AFE4900EVM GUI (可在 [AFE4900EVM](http://www.ti.com/sc/techlit/AFE4900EVM)) 的截图。

3.1.2 Software

The following software tools were used to test and obtain the results for this TI reference design:

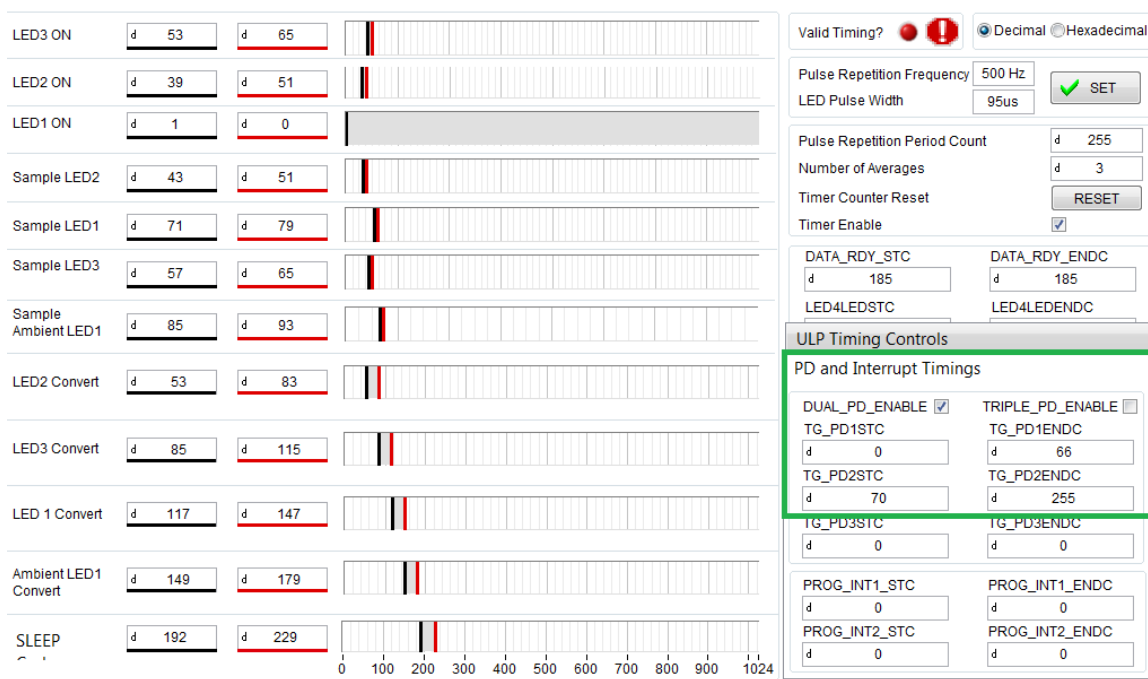
- Code Composer Studio™ (CCS), version 7 or higher (should be installed with CC26xx support. Run installer again if CC26xx support is not already installed)
- [SIMPLELINK-CC2640R2-SDK Software](#)
- [LAUNCHXL-CC2640R2](#)
- LabVIEW™ 2016 Development Engine or Runtime Engine (32-bit)
- JAVA Runtime Engine (32-bit)

The following instructions assume that CCS, SIMPLELINK-CC2640R2-SDK, LabVIEW and JAVA are installed on the PC. Download the LabVIEW application setup (zip file) from the [TIDA-01580 product page](#). This setup installs the firmware containing four project folders (two for the transmit section and two for the receive section) and the LabView application folder containing executable file and source files.

3.1.2.1 Software Loading for TIDA-01580 Board (Transmit Side of BLE)

1. Plug in the LAUNCHXL-CC2640R2 board on the USB port of the PC. See the setup in [图 33](#) and [图 34](#). [表 16](#) lists the connections between the TIDA-01580 board and the LAUNCHXL-CC2640R2 board.



图 33. Programming TIDA-01580 Board Using LAUNCHXL-CC2640R2

2. Insert one CR3032 battery into the BT1 connector on the TIDA-01580 board, and power it on by using the S2 switch (ensure J8 is shorted on the TIDA-01580 board).
3. Open CCS as administrator (Right click on the CCS icon and run as administrator).
4. Click on the Project option in the main toolbar and then click Import CCS projects.

5. Browse to select the installed firmware (Default: C:\Program Files (x86)\Texas Instruments\TIDA-01580\TIDA-01580_firmware) and import all projects. Click the OK button.
6. Click View, Project Explorer and select TIDA-01580_firmware_tx.
7. Click on the Run and Debug buttons. This action programs the board with the selected project file.
8. Disconnect the TIDA-01580 board from the LAUNCHXL-CC2640R2 device.

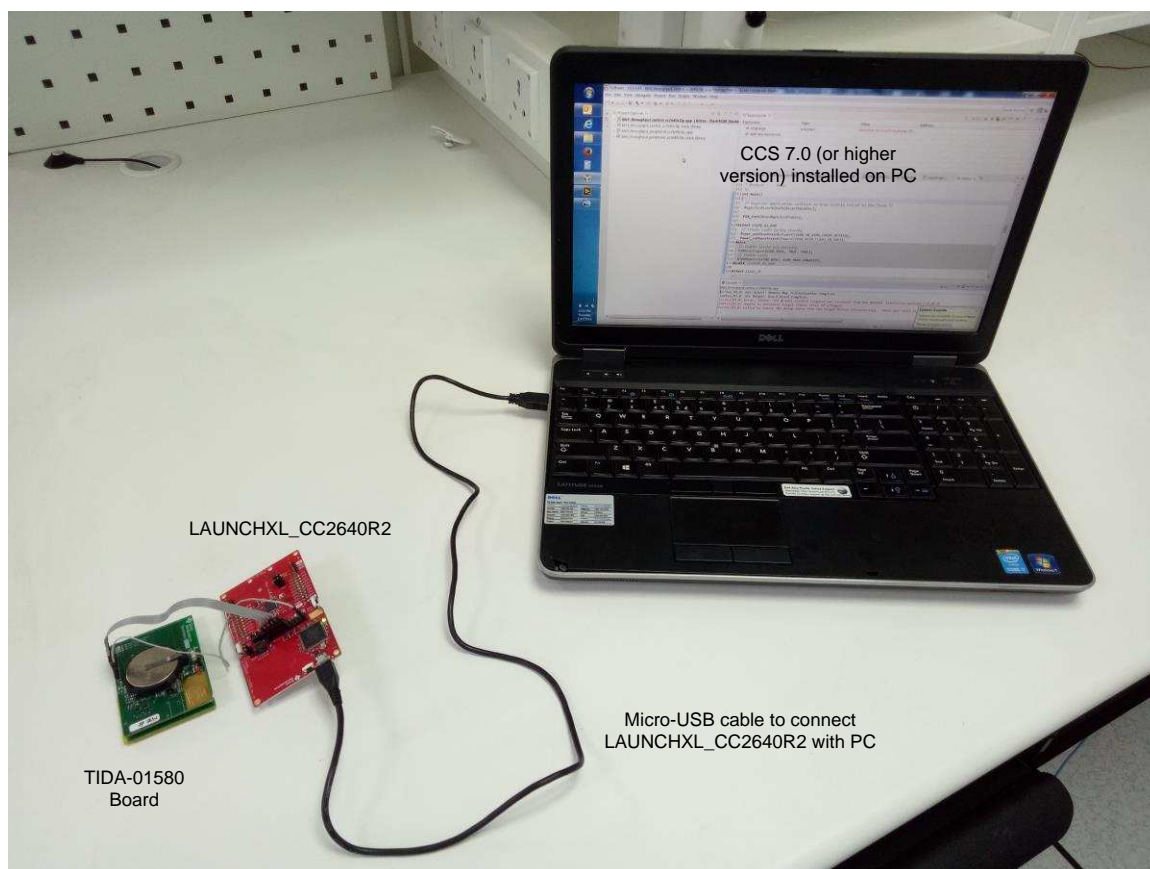

图 34. Connections Between TIDA-01580 Board and LAUNCHXL-CC2640R2

表 16. Connections for Programming TIDA-01580 Using LAUNCHXL-CC2640R2

CONNECTION ON LAUNCHXL-CC2640R2 (ON XDS110 OUTSIDE)	PIN NO.	CONNECTION ON TIDA-01580 BOARD (CONNECTOR J6)	PIN NO.
GND	1	GND	1
RESET	6	CC_RESET	7
TMS	7	JTAG_TMSC	6
TCK	8	JTAG_TCKC	5
TDI	9	TDI	4

表 16. Connections for Programming TIDA-01580 Using LAUNCHXL-CC2640R2 (continued)

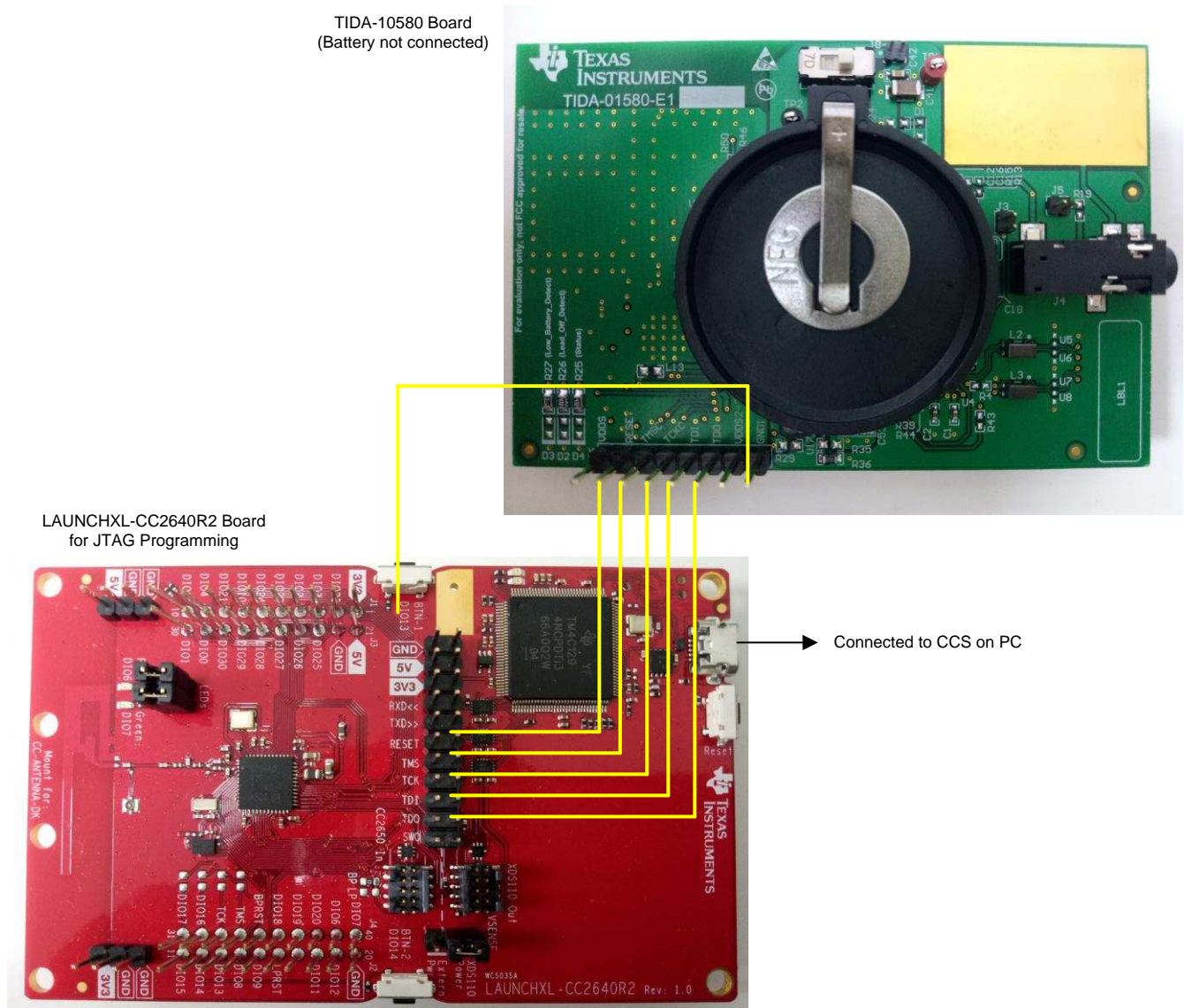
CONNECTION ON LAUNCHXL-CC2640R2 (ON XDS110 OUTSIDE)	PIN NO.	CONNECTION ON TIDA-01580 BOARD (CONNECTOR J6)	PIN NO.
TDO	10	TDO	3

3.1.2.2 LabVIEW™ File Execution for Checking Measurement Data (Receive Side of BLE)

注: Only one device, the LAUNCHXL-CC2640R2 or XDS110, can be connected to the PC while running the executable file.

1. Insert one CR3032 battery into the BT1 connector on the TIDA-01580 board and power it on by using the S2 switch (ensure J8 is shorted on the TIDA-01580 board). Ignore this step if it was already done during programming of the TIDA-01580 board.
2. Revert back to the original LaunchPAD jumper settings.
3. Plug in the LAUNCHXL-CC2640R2 device on the USB port of the PC.
4. Open the Setup_TIDA-01580.exe file and go through the installation process, explained as follows.
 1. Setup Welcome Screen – click Next.



图 35. Setup Welcome Screen

- License Agreement Screen – Accept the agreement and click Next.

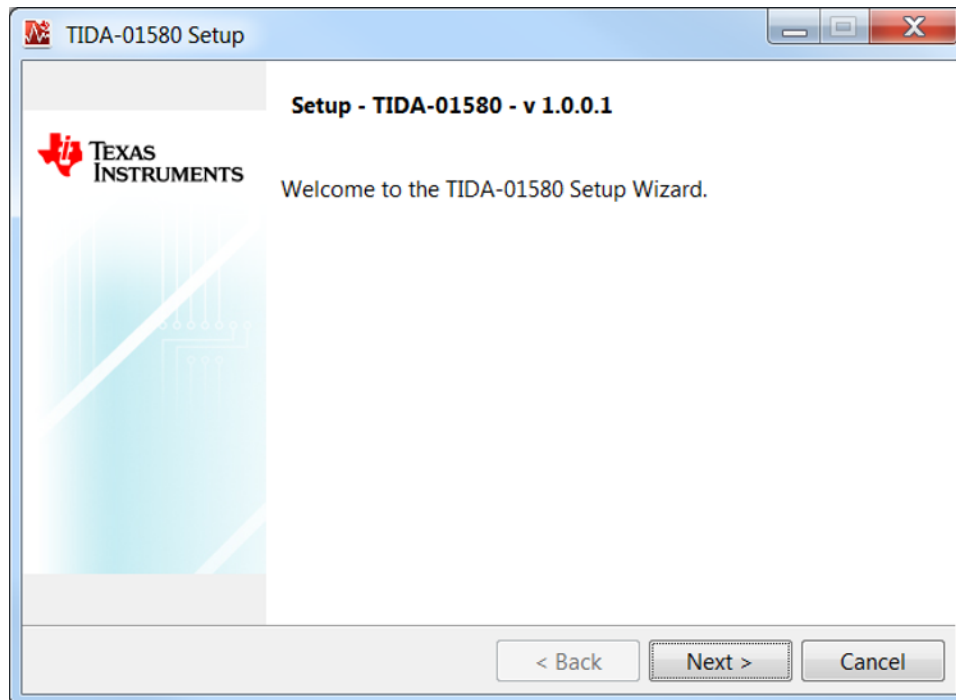

图 36. License Agreement Screen

- Installation Directory Screen – click Next.

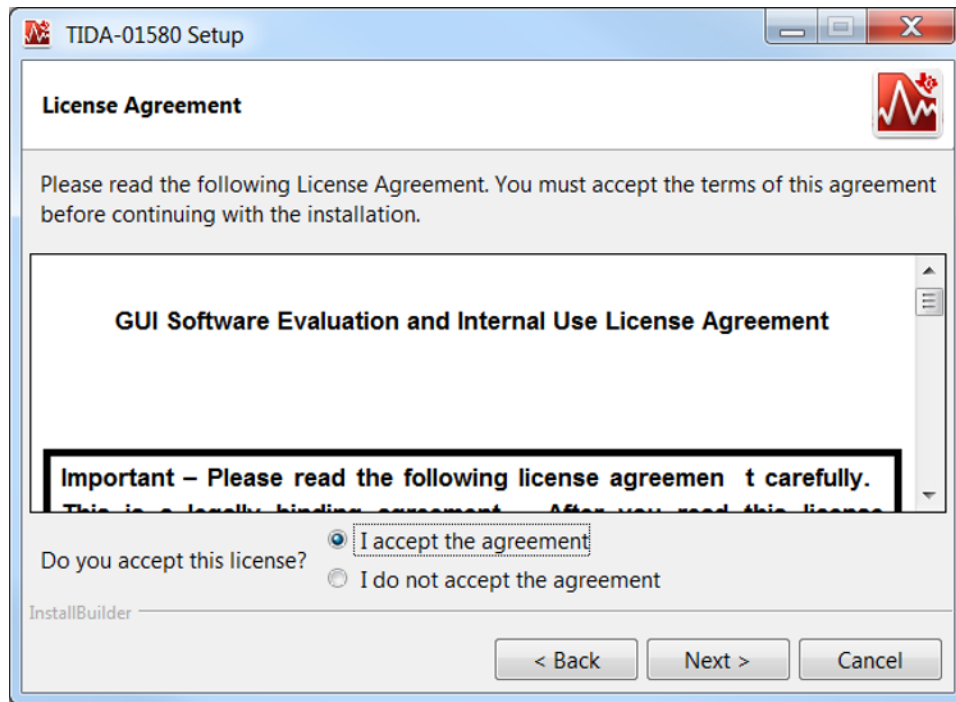

图 37. Installation Directory Screen

4. Select Components Screen – click Next.

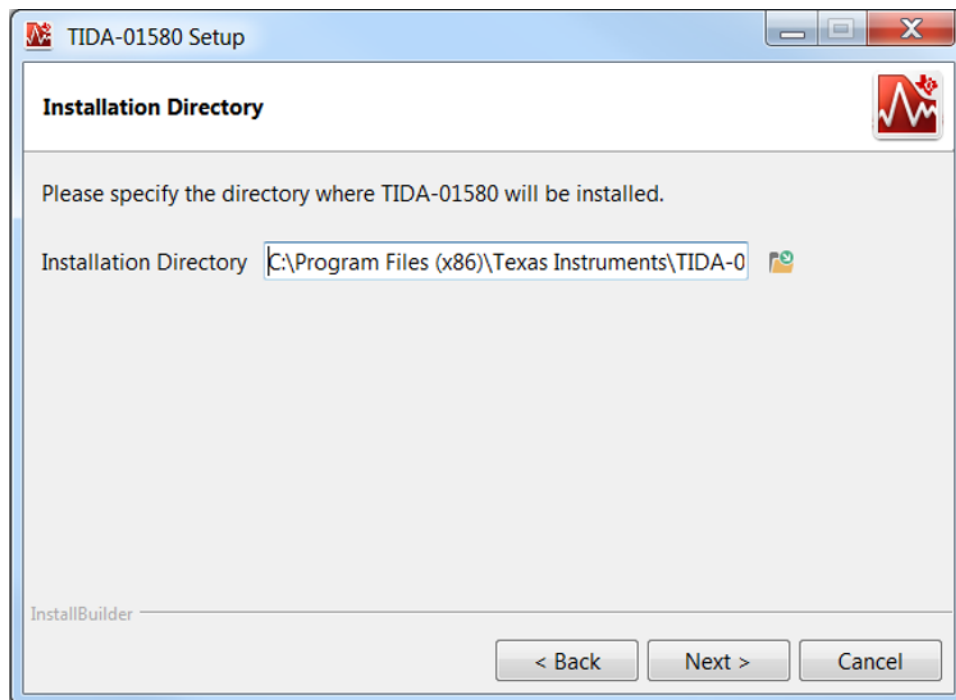

图 38. Select Components Screen

5. Ready to Install Screen – click Next.

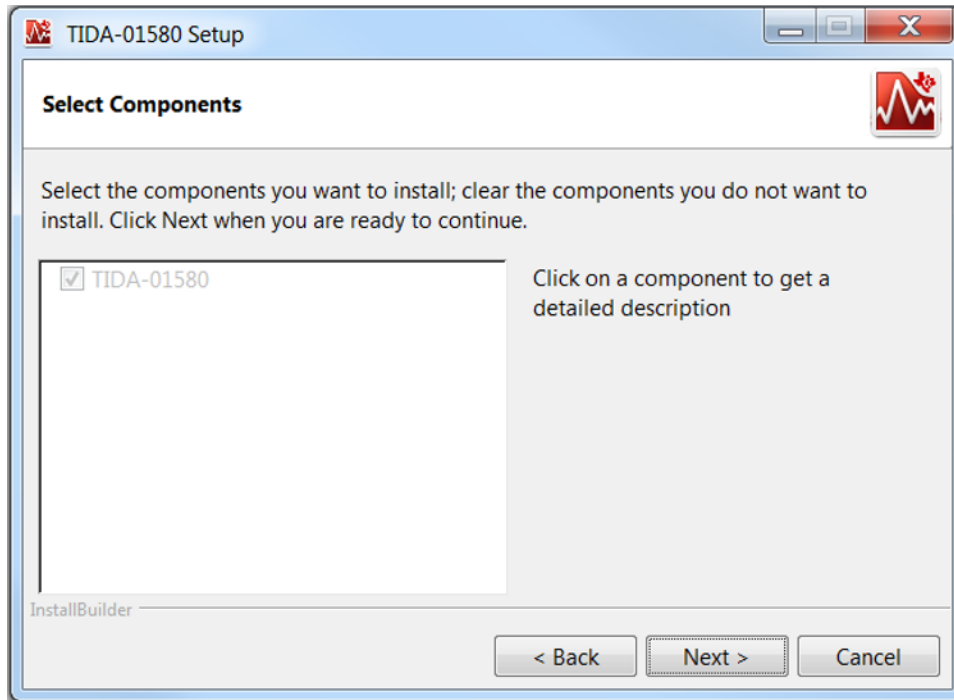

图 39. Ready to Install Screen

The setup starts installing and the progress screen is displayed (see 图 40).

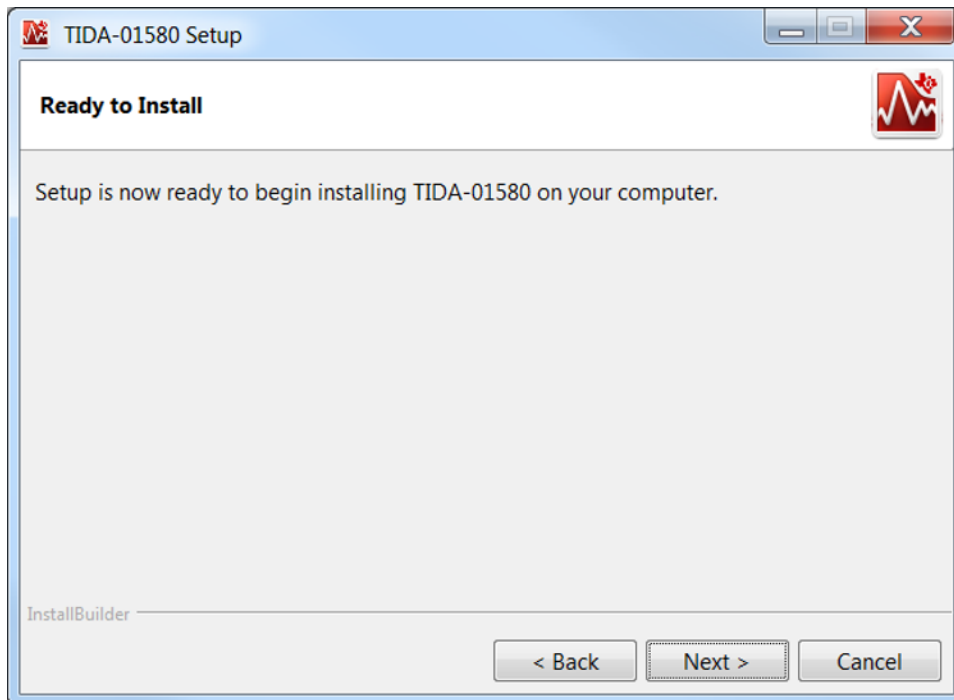

图 40. Installing GUI

- When installed, click Finish. Look for the TIDA-01580 Application.exe at the installed location (default location: C:\Program Files (x86)\Texas Instruments\TIDA-01580\TIDA-01580 Application).

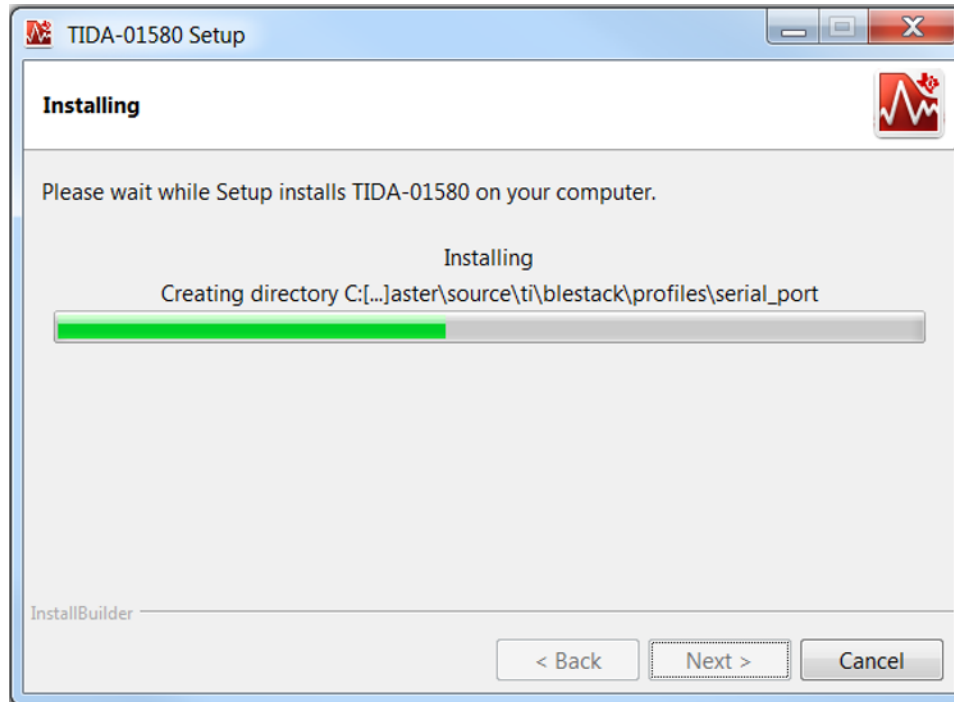

图 41. Completing TIDA-01580 Setup Wizard

While launching the GUI, a splash screen appears, as shown in 图 42.

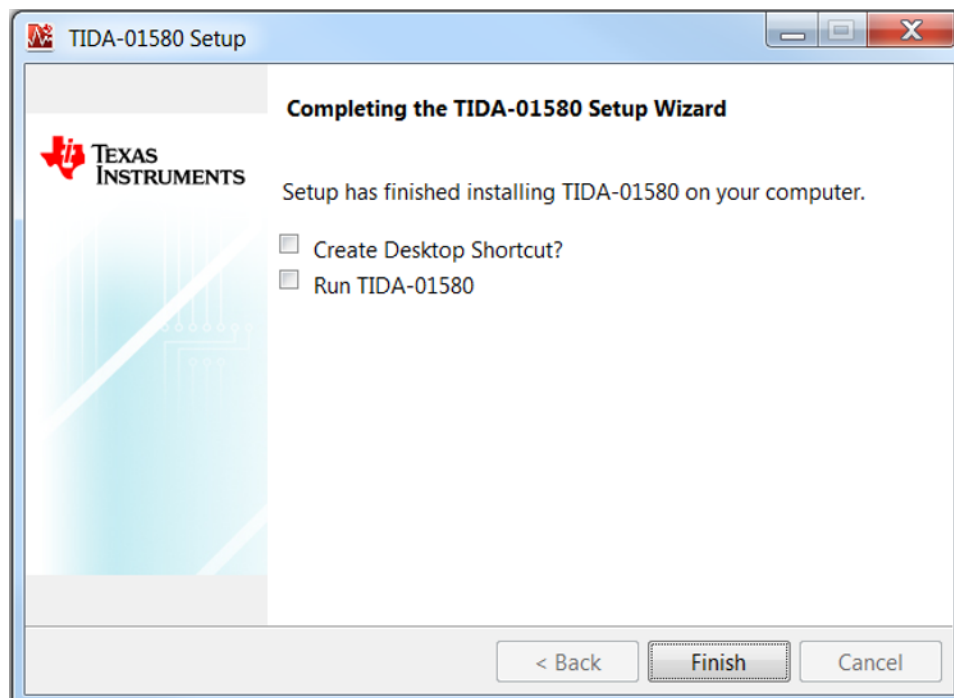

图 42. Splash Screen on Launching TIDA-01580 GUI

The Instructions tab provides instructions and safety precautions for the user, as shown in 图 43.



图 43. TIDA-01580 GUI Instructions Tab

The Configurations tab (see [图 44](#)) provides information about the software paths.

1. Ensure the CCS base-folder path is set to <CCS installation path>\ccsv7\ccs_base.
2. Ensure the project .OUT file path is set to <installation folder>\TIDA-01580_firmware\TIDA-01580_firmware_rx\FlashROM_StackLibrary\TIDA-01580_firmware_rx.out.
3. The START/STOP button can connect and program the LAUNCHXL-CC2640R2 device to capture the data. After clicking the START/STOP button, the TIDA-01580 board must immediately be power cycled using the S2 switch. The START/STOP button can also disconnect the link.



图 44. TIDA-01580 GUI Configurations Tab

The HRM tab (see 图 45) shows PPG data taken from green LED and ECG data. The HRM tab estimates heart-rate from both sets of data (time difference in seconds between two peaks of PPG or ECG data / 60).

注: As soon as the BLE connection is established, the Configurations tab switches to the HRM tab.

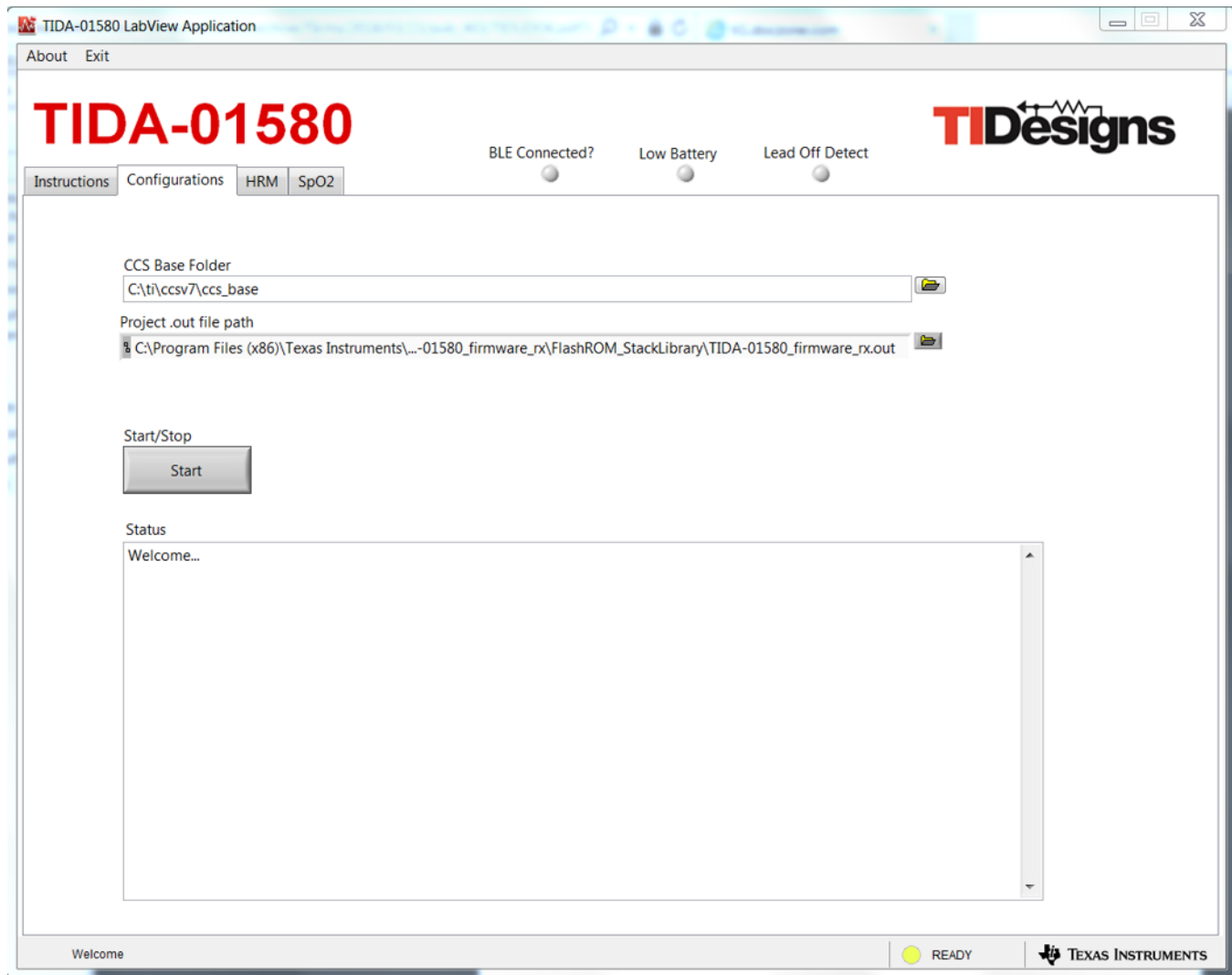

图 45. TIDA-01580 GUI HRM Tab

The SpO2 tab (see 图 46) shows PPG data taken from the red and IR LEDs. The SpO2 tab estimates % SpO2 from both sets of data.

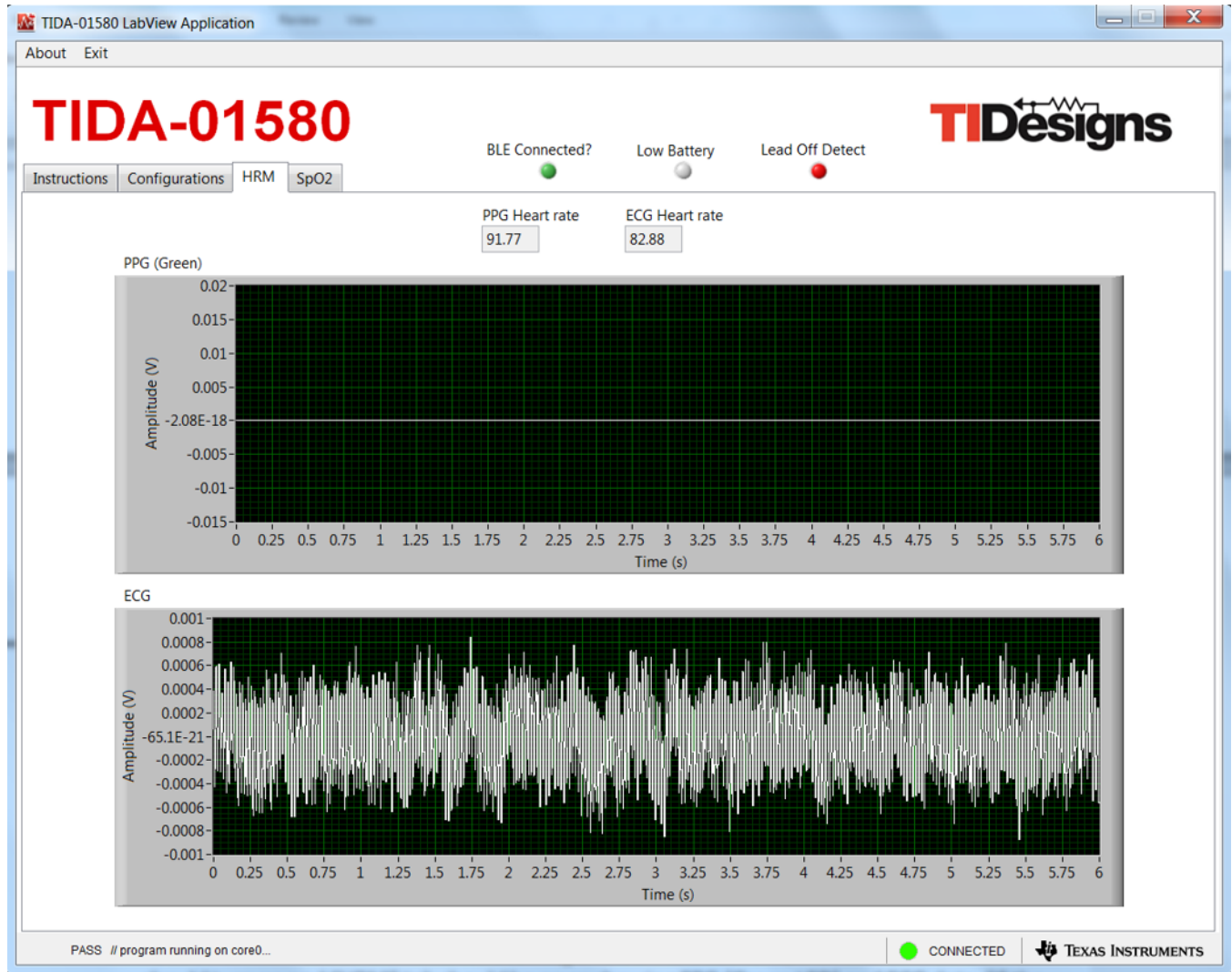

图 46. TIDA-01580 GUI SpO2 Tab

- The LED indication of BLE Connected? turns on if the LAUNCHXL-CC2640R2 receiver is connected with the TIDA-01580 board over BLE.
- The LED indication of Low Battery turns on if the battery voltage is less than 2 V.
- The LED indication of Lead Off Detect turns on if any one of the ECG electrodes are not connected to the human body.
- The Exit button can disconnect and quit the .exe file.

3.2 Testing and Results

This section describes the test setup and test results for the TIDA-01580 board (see 图 47).

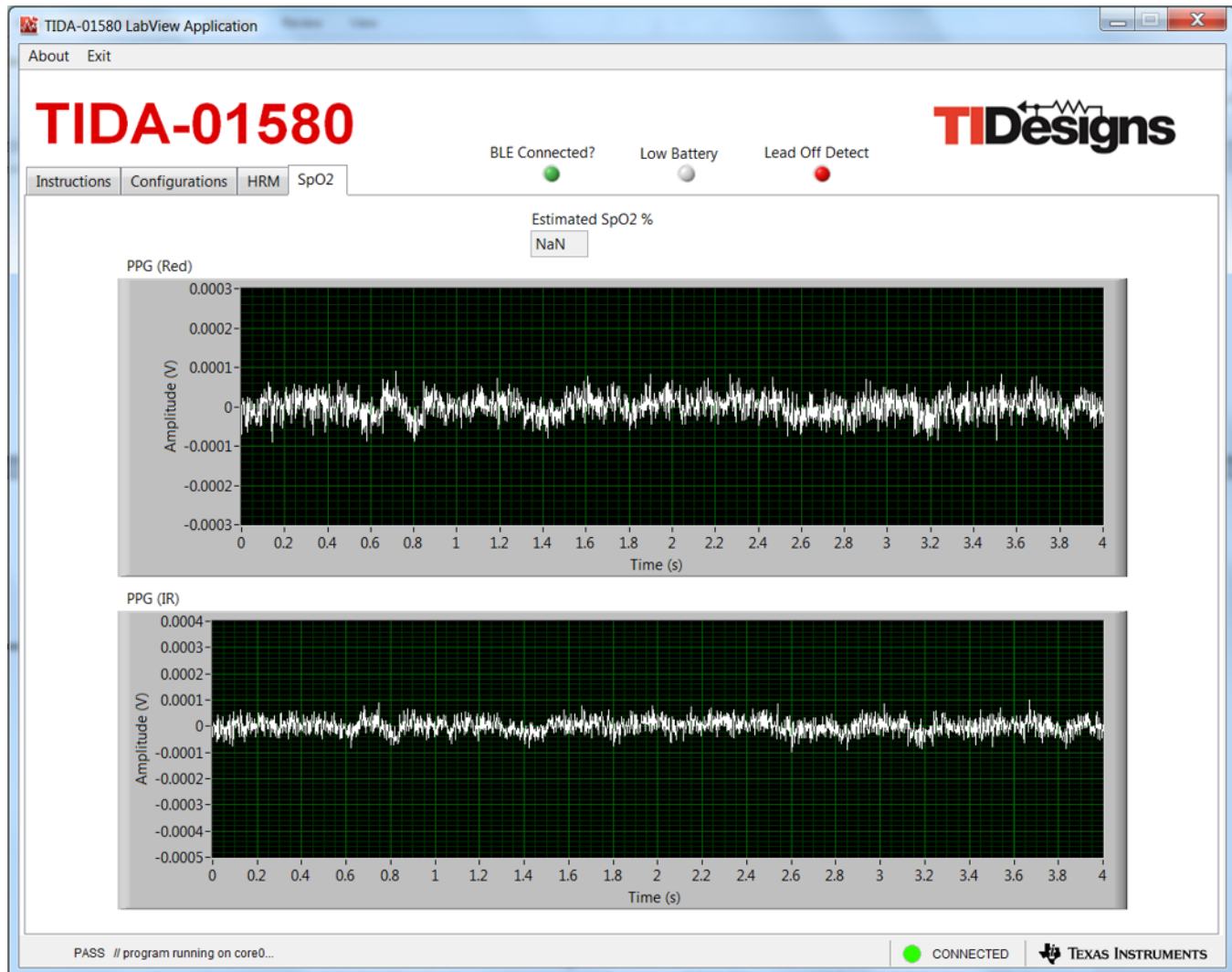

图 47. Test Setup for Capturing Data

3.2.1 Test Setup

1. Plug in the LAUNCHXL-CC2640R2 device on the USB port of the PC.
2. Open TIDA-01580 Application.exe file.
3. Connect the human body (fingers or wrist) to the TIDA-01580 board for the measurement. Ensure the PPG sensor on the bottom side is covered by a finger. For ECG measurement, two electrodes are used. One electrode is on the bottom side touched by one hand, and another electrode is formed by touching the top side using a second hand.
4. Ensure the paths are correct for the CCS Base Folder and Project .out file on the Configurations tab.
5. Click on the START/STOP button in the Configurations tab on the TIDA-01580 GUI.
6. Power-cycle the TIDA-01580 board by toggling the S2 switch.
7. The Configurations Tab shows the following message:

```
Welcome...
Advanced filtering is disabled in the Run Time Engine
PASS // core0 connected as Cortex_M3_0...
PASS // program file loaded on core0...
PASS // program running on core0...
```

As soon as the TIDA-01580 board connects to the receiving LAUNCHXL-CC2640R2 board, the BLE Connected? LED turns on, and the HRM tab should be open showing PPG (green LED) and ECG data. If the ECG electrodes are not connected properly, the Lead Off Detect LED turns on. The SpO2 tab can be used for measuring PPG data from the red and IR LEDs.

8. Once evaluation is over, click on the START/STOP button in the Configurations tab. The tab shows the following message:

```
PASS // closing tcp session on port 1444..
```
9. Click on the Exit button to quit the .exe file.

3.2.2 Test Results

3.2.2.1 Heart-Rate Measurement Using PPG (Green LED) and ECG

图 48 和 图 49 显示 HRM 和 ECG 数据来自 SFH 7072 和 OCS112 传感器。



图 48. HRM Data From SFH 7072 Sensor and ECG Data



图 49. HRM Data From OCS112 Sensor and ECG Data

3.2.2.2 SpO2 Measurement Using Red and IR LEDs

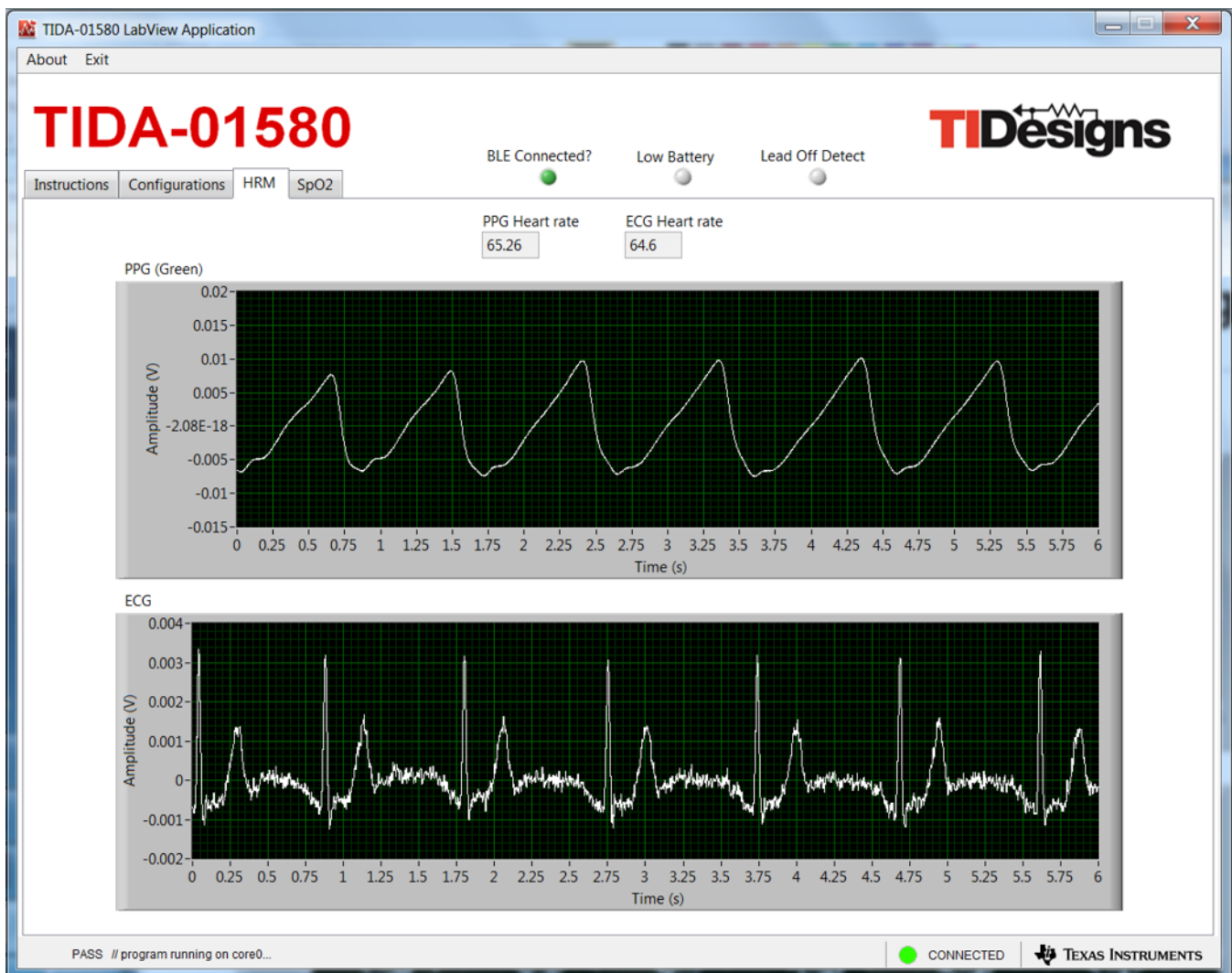
图 50 和 图 51 显示 SpO2 和 ECG 数据来自 SFH 7072 和 OCS112 传感器。

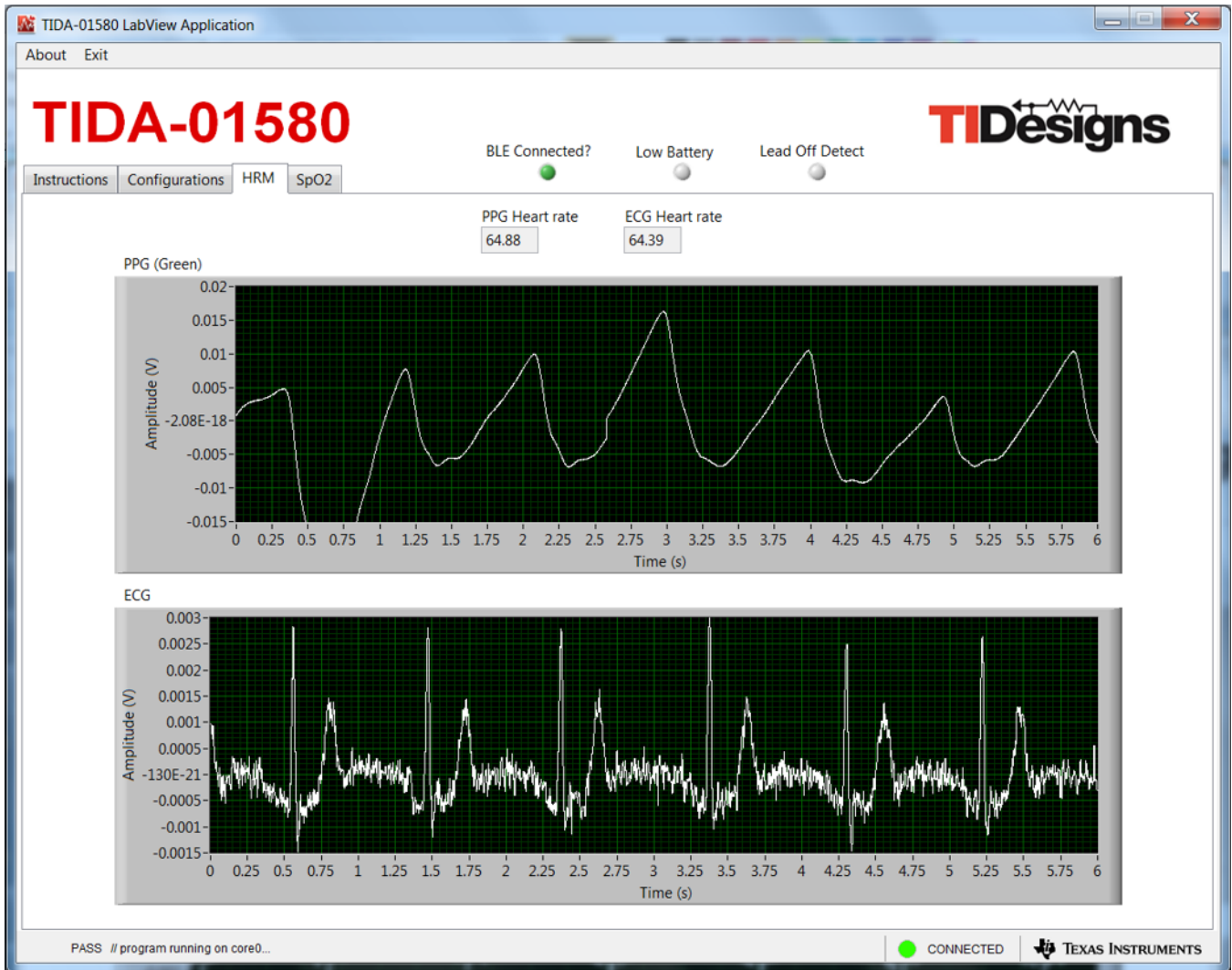

图 50. SpO2 Data From SFH 7072 Sensor and ECG Data



图 51. SpO2 Data From OCS112 Sensor and ECG Data

3.2.2.3 PTT Measurement

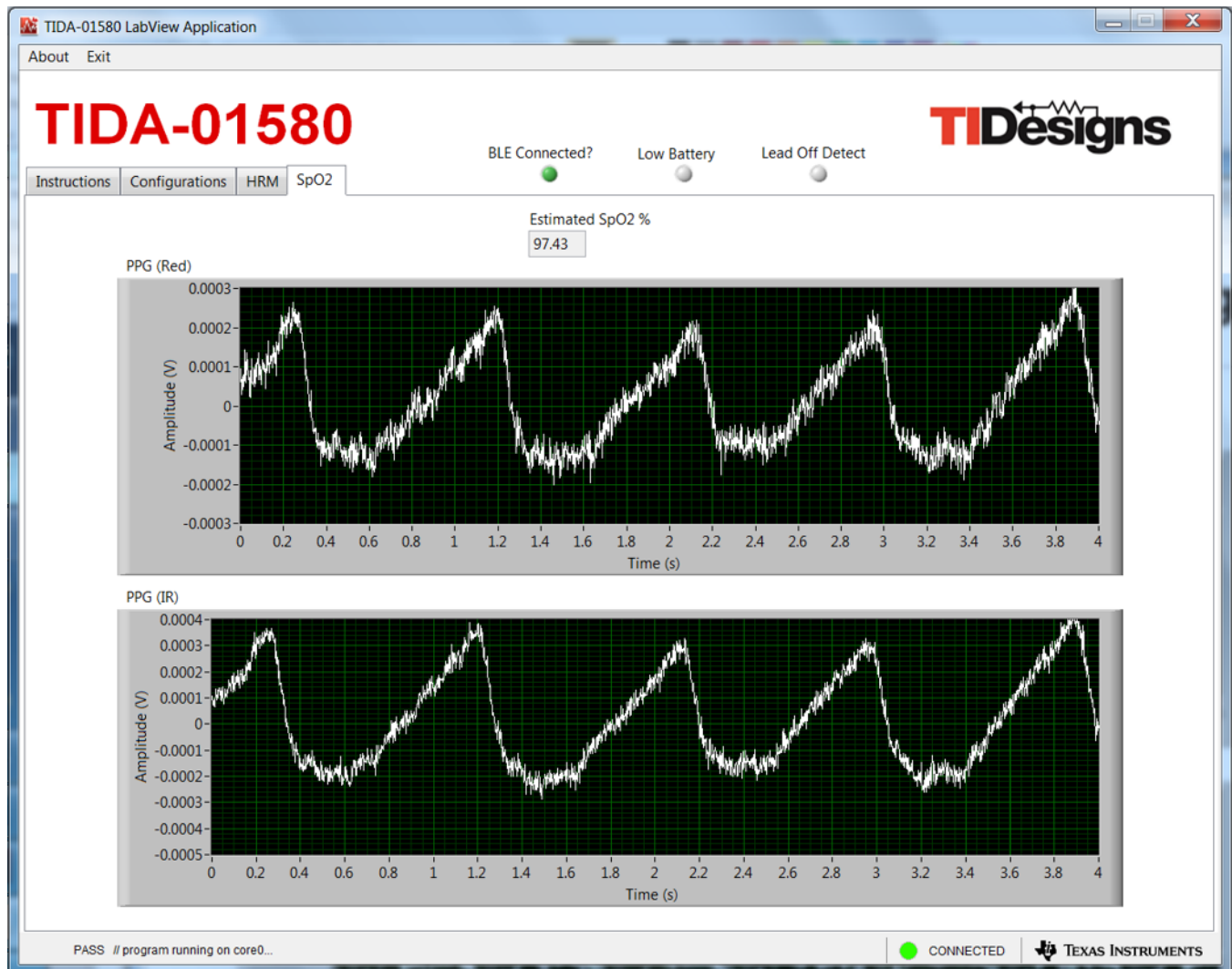
图 52 shows the PTT measurement.

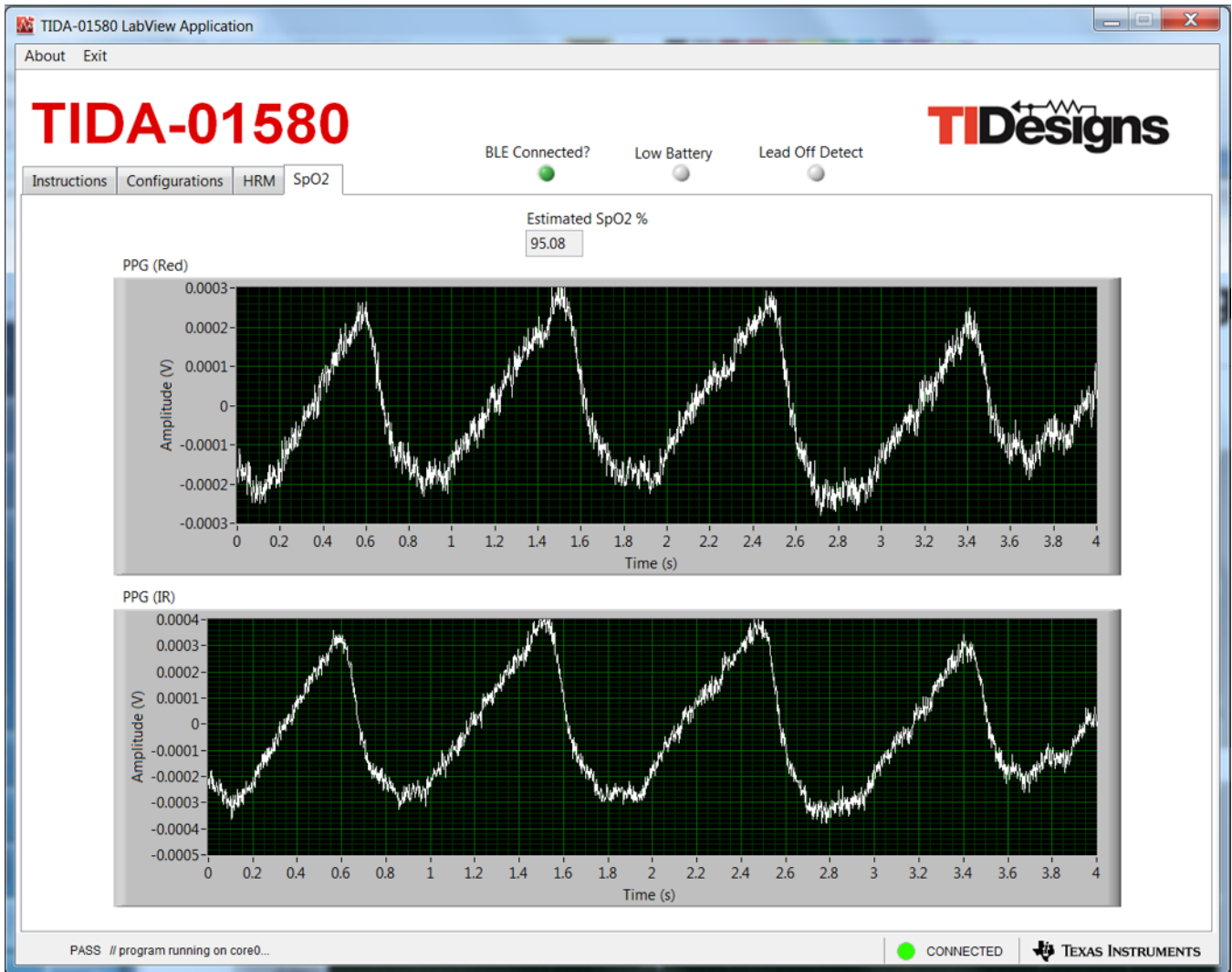

图 52. Measurement Showing Constant PTT

注: During testing, it was observed that the power line noise and other motion artifacts getting coupled to the PPG signals drastically reduced the SNR. For HRM applications, it is imperative to remove the noise and baseline drift. Heart-rate estimation usually requires an algorithm that filters the noise and detects the beat-to-beat heart rate and average heart rate. Even under rest conditions, extraction of heart rate data can get complicated, due to sudden changes in the DC level of the signal, due to respiration and motion artifacts. The heart rate can be calculated by measuring the separation between the successive peaks of the signal after eliminating the effect of the sudden DC-level shifts. In the presence of artifacts such as motion, the PPG signal can be buried. This occurrence requires motion cancellation algorithms, usually aided by data from accelerometers, to be able to remove the motion artifact and extract the heart rate.

3.2.2.4 Lead-Off Detect

Lead-off detect is implemented on the TIDA-01580 board. The onboard LED D2 indicates the same. Lead-off detection is also highlighted on the TIDA-01580 GUI by turning on the LED.

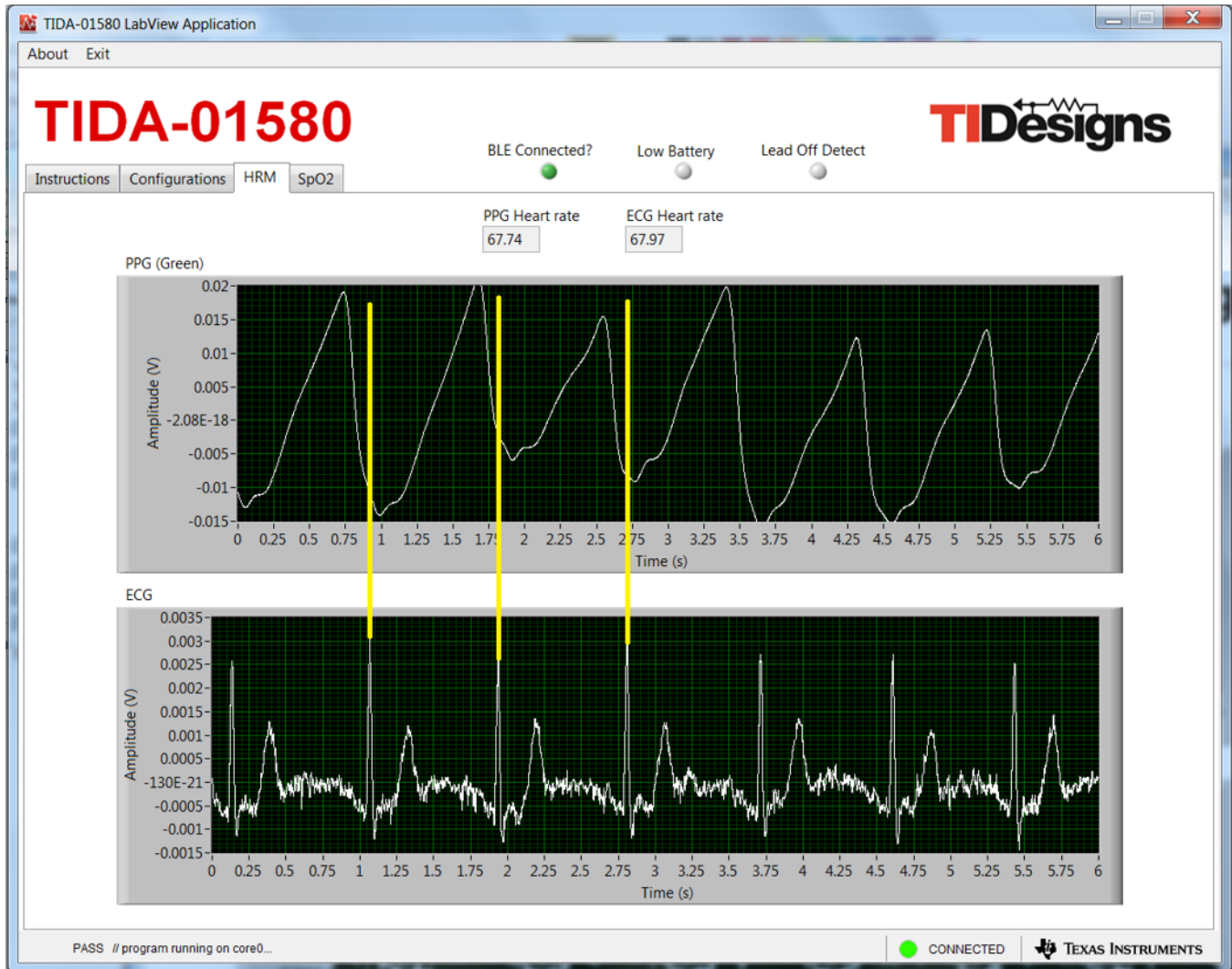
3.2.2.4.1 AC Lead-Off Detect

图 53 shows the settings for AC lead-off detection (using the AFE4900 EVM GUI).



图 53. Settings for AC Lead-Off Detection

3.2.2.4.2 DC Lead-Off Detect

图 54 shows the settings for DC lead-off detection (using the AFE4900 EVM GUI).

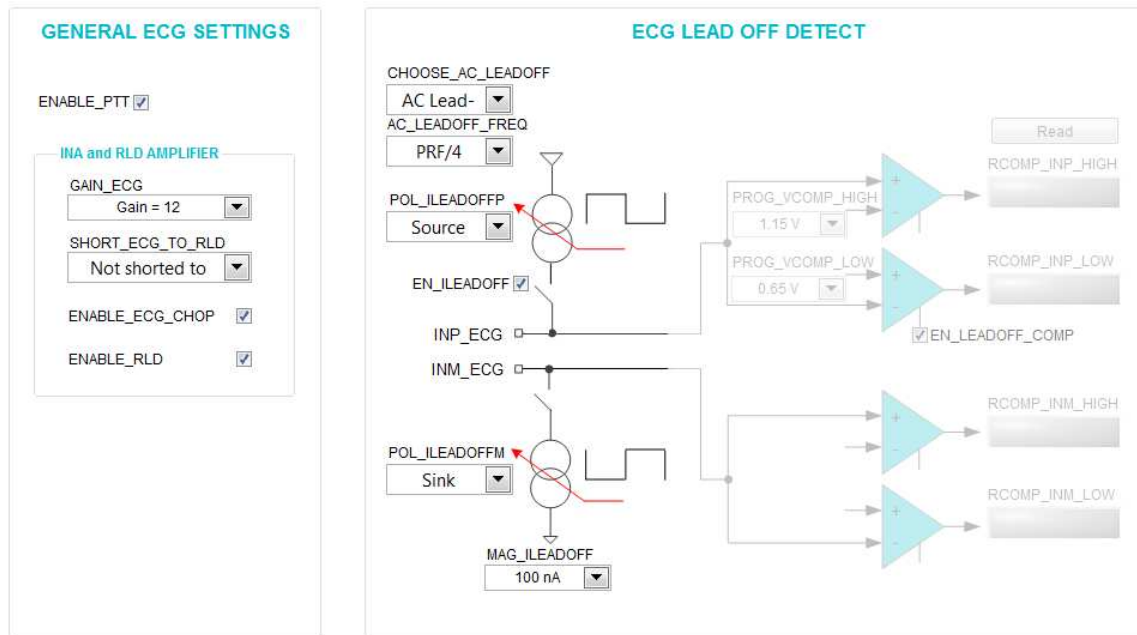

图 54. Settings for DC Lead-Off Detection

3.2.2.5 Low-Battery Indication

Low-battery indication is implemented on the TIDA-01580 board. The onboard LED D3 indicates the same. Low-battery is also highlighted on the TIDA-01580 GUI by turning on the LED. The low-battery detection threshold is set at 1.9 V.

3.2.2.6 Waveforms for DC/DC Converters

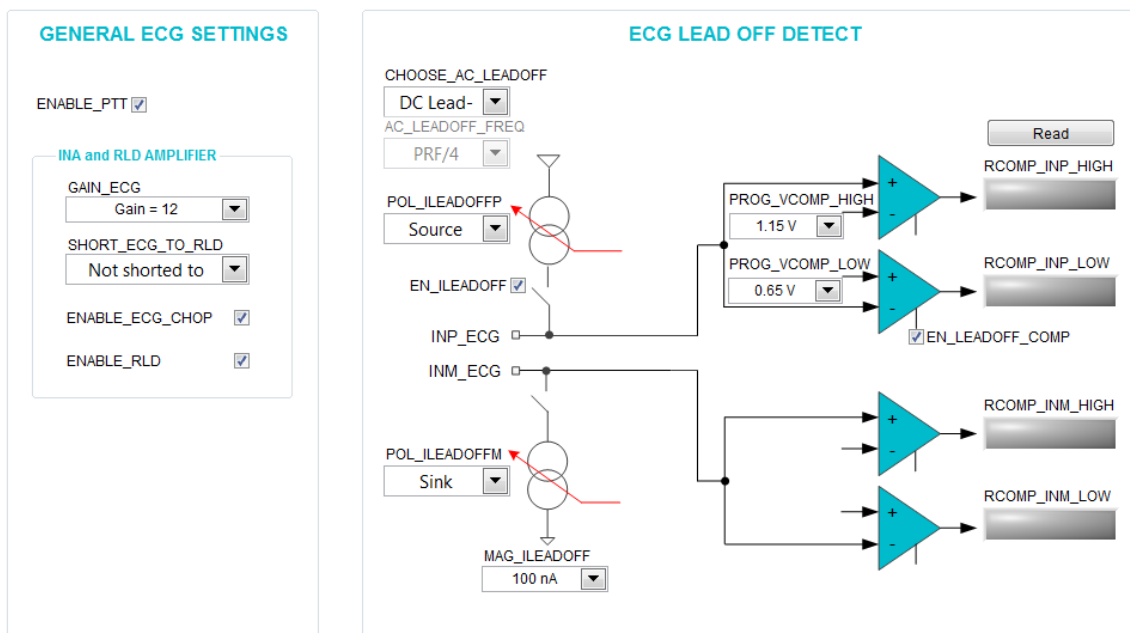
图 55 through 图 59 show waveforms for DC/DC converters.



图 55. Waveform Showing Ibattery (Pink), RX_SUP (Yellow), TX_SUP (Green), and Vbattery (Purple)



图 56. Waveform Showing Ibattery (Pink), Ripple on RX_SUP (Yellow), Ripple on TX_SUP (Green), and Ripple on Vbattery (Purple)

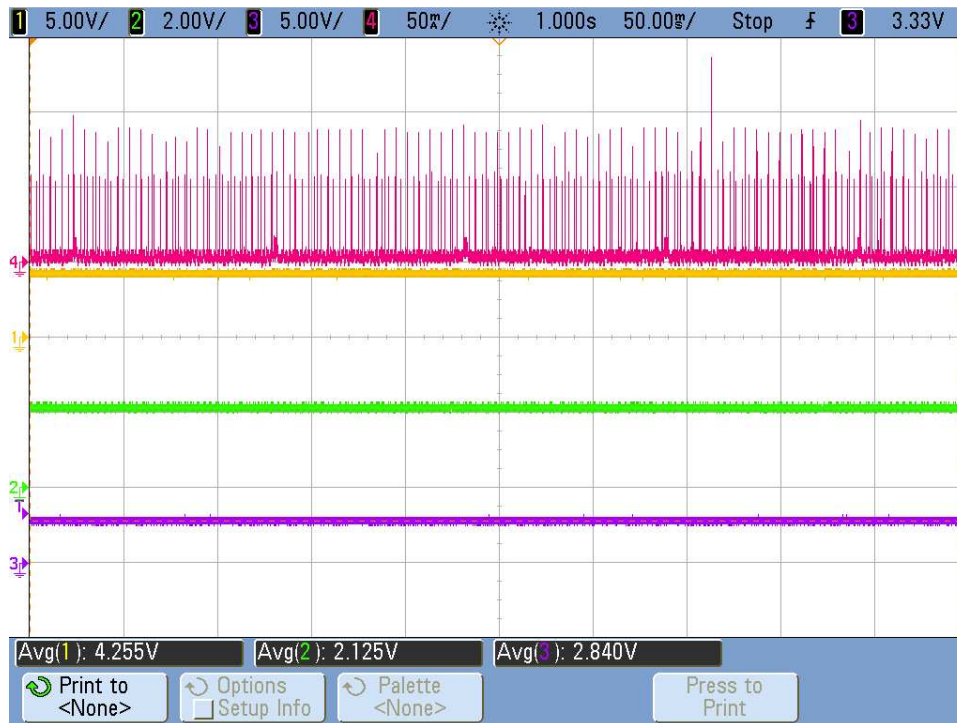

图 57. Pink Waveform Shows 100-ms Advertising Time for BLE

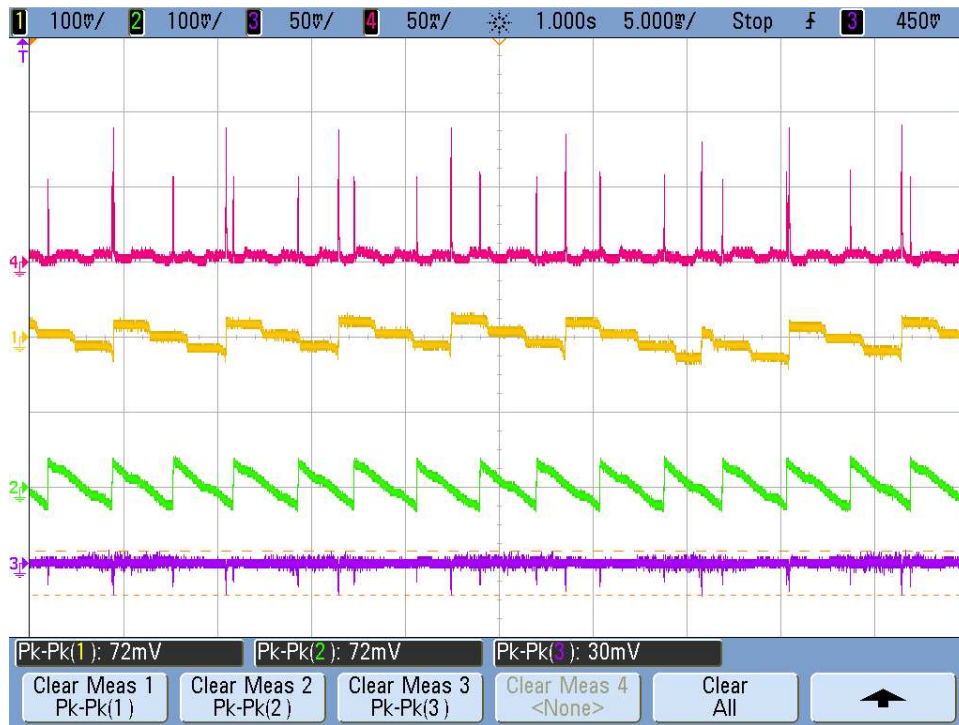

图 58. Three Pulses Showing Standard Advertising for BLE

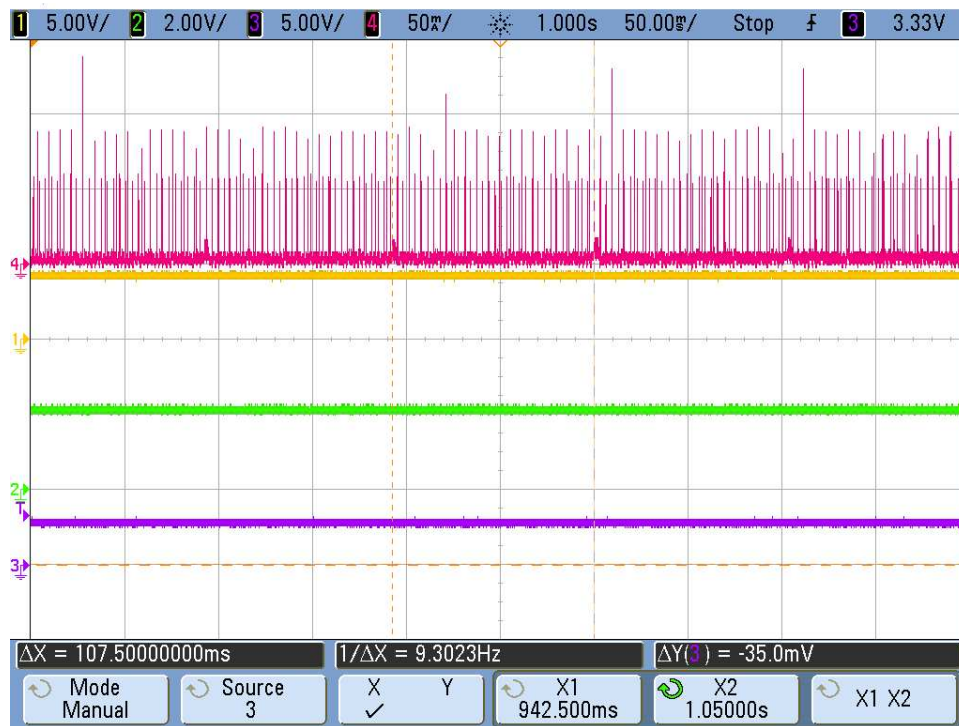

图 59. Pulse Showing Standard BLE Once Connected

3.2.2.7 Battery Life Test

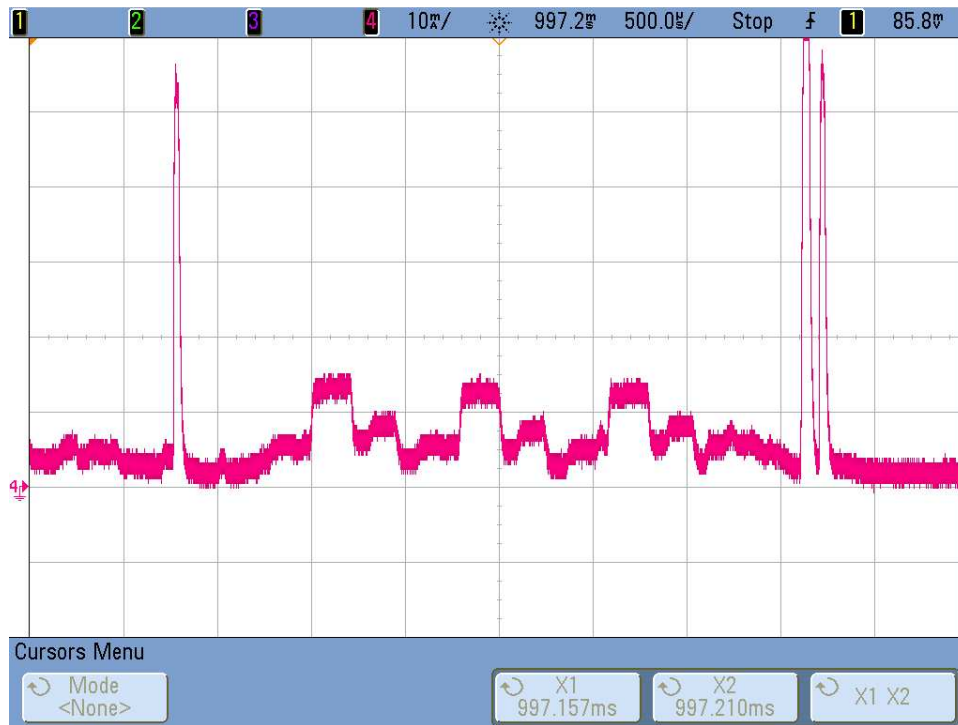
The battery life test is done by keeping the TIDA-01580 board on for continuous transmission of the data. The CR3032 battery works continuously for 100 hours.

4 Design Files

4.1 Schematics

To download the schematics, see the design files at [TIDA-01580](#).

4.2 Bill of Materials

To download the bill of materials (BOM), see the design files at [TIDA-01580](#).

4.3 PCB Layout Recommendations

Device-specific layout guidelines for each TI part used in this design can be found in the corresponding data sheets. 图 25 和 图 26 显示 TIDA-01580 PCB 的顶部和底部视图，分别。重要的部分用红色箭头和说明突出显示。

4.3.1 Layout for Main Board



图 60. Top Layer for TIDA-01580 Board



图 61. Bottom Layer for TIDA-01580 Board

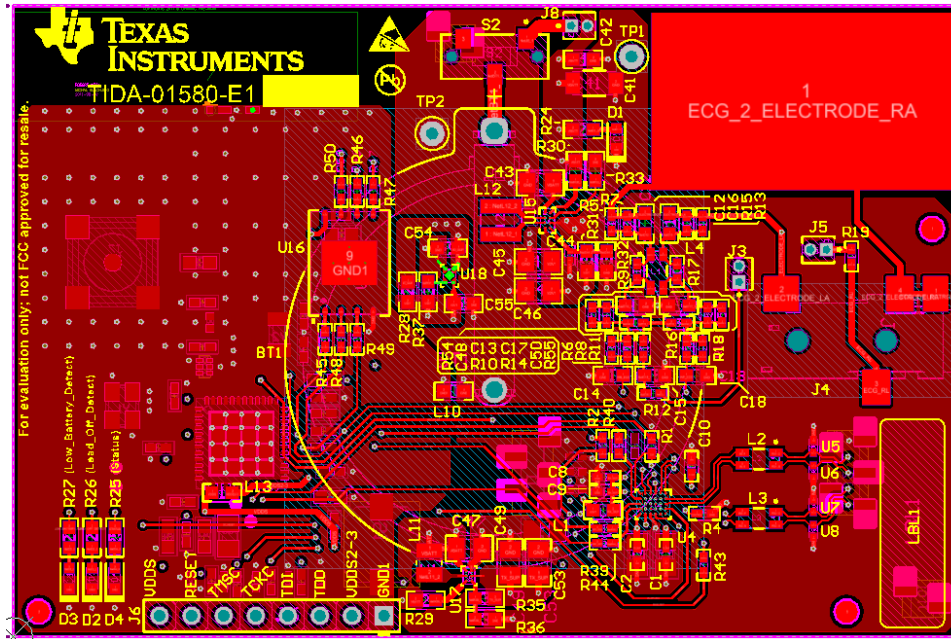

图 62. Power Layer for TIDA-01580 Board

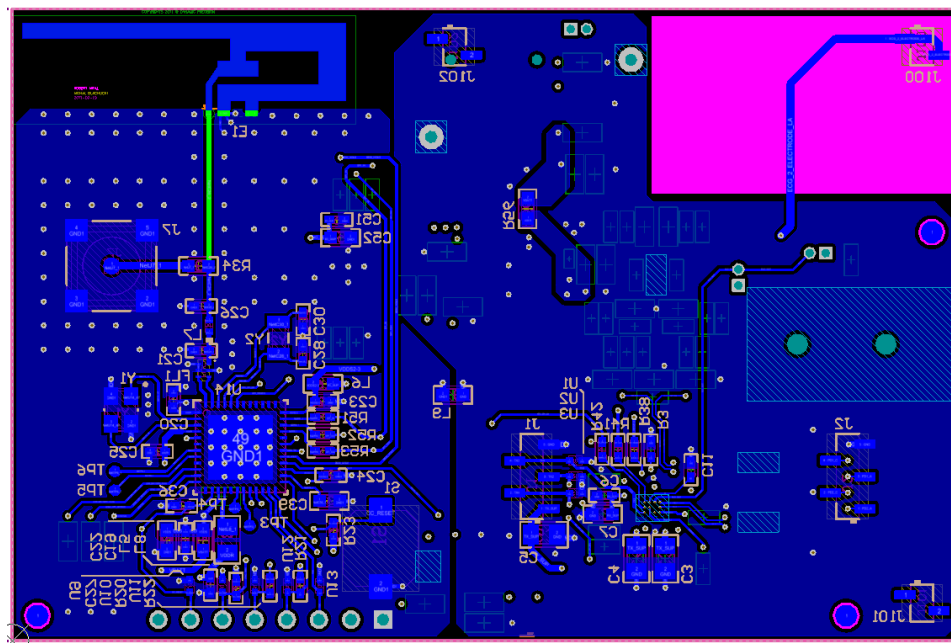

图 63. Ground Layer for TIDA-01580 Board

4.3.2 Connection From PDs to AFE

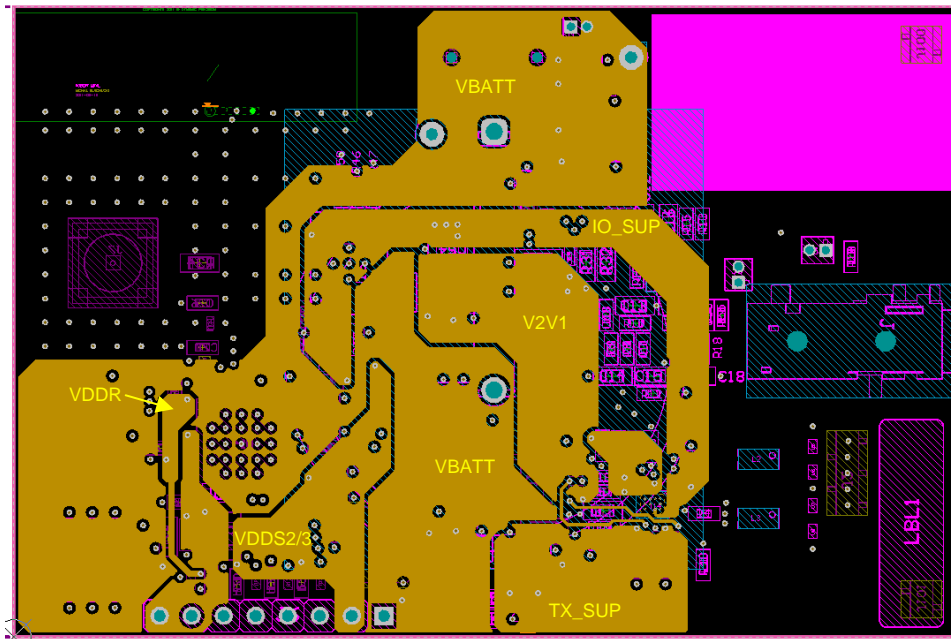

图 64. Traces From PDs to AFE

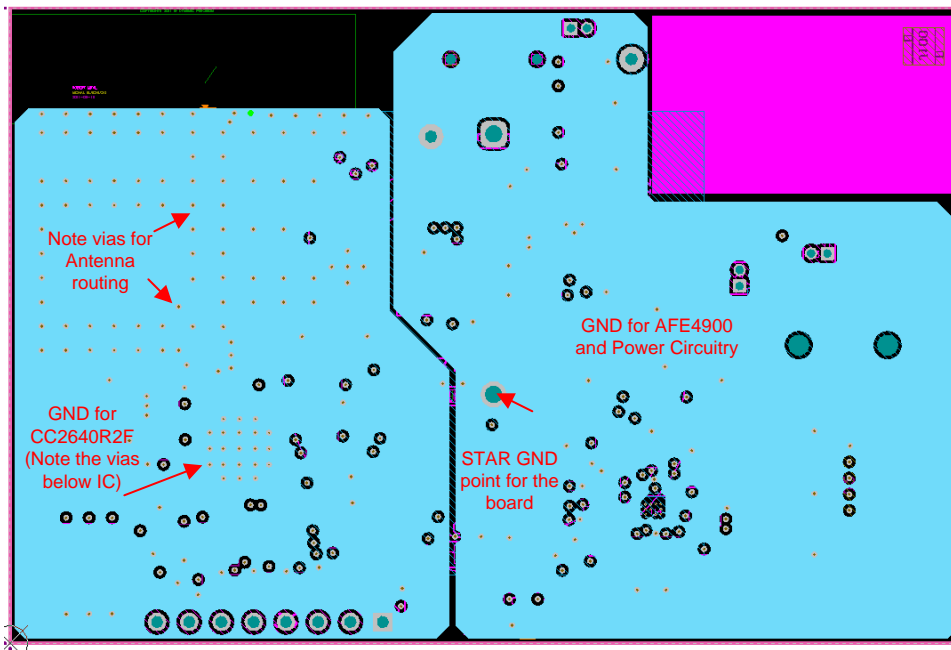
4.3.3 Connections From LEDs to AFE

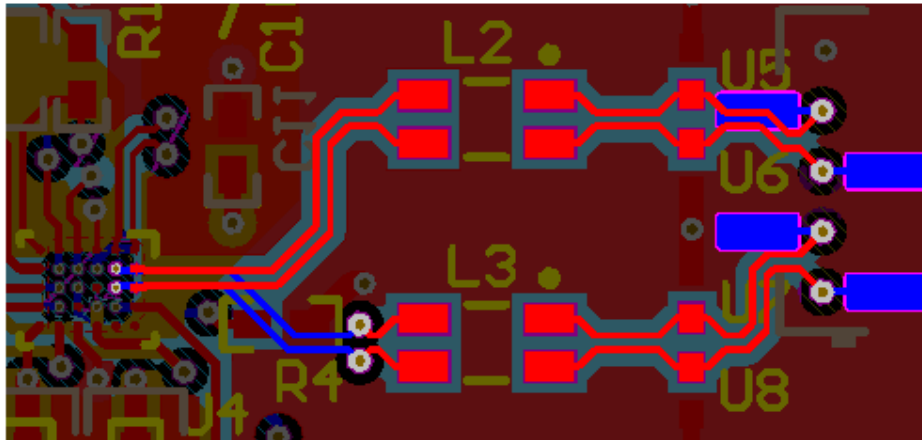

图 65. Traces From LEDs to AFE

4.3.5 Connections Between BT and AFE

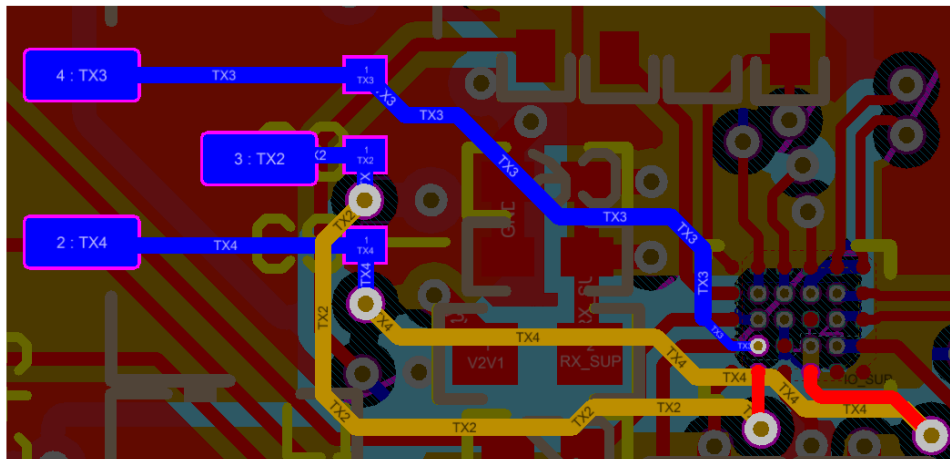

图 67. Traces Between CC2640R2F and AFE4900

4.3.7 Boost Converter

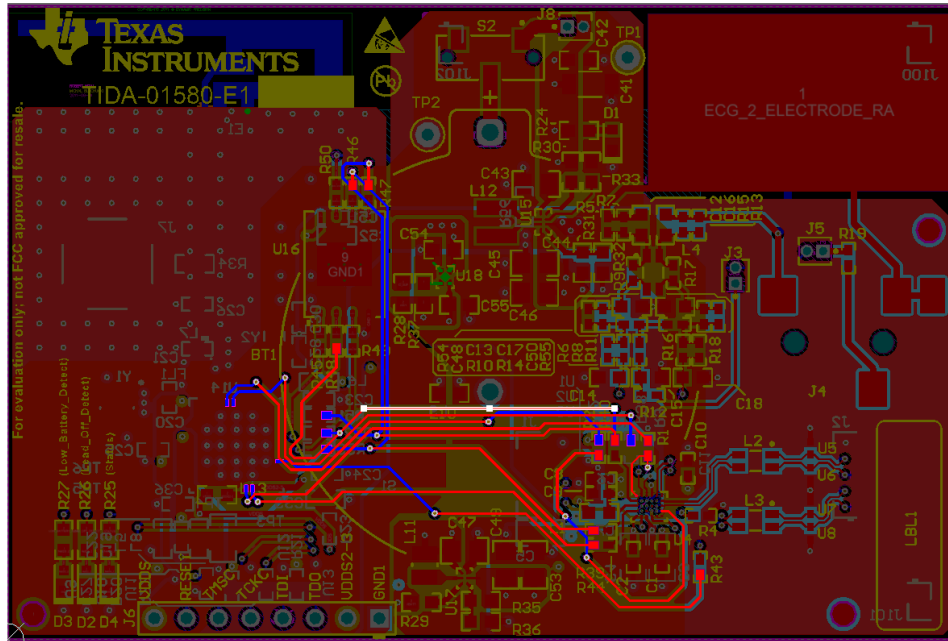

图 69. Layout and Traces for Boost Converter, TPS61099

4.3.8 Buck-Boost Converter

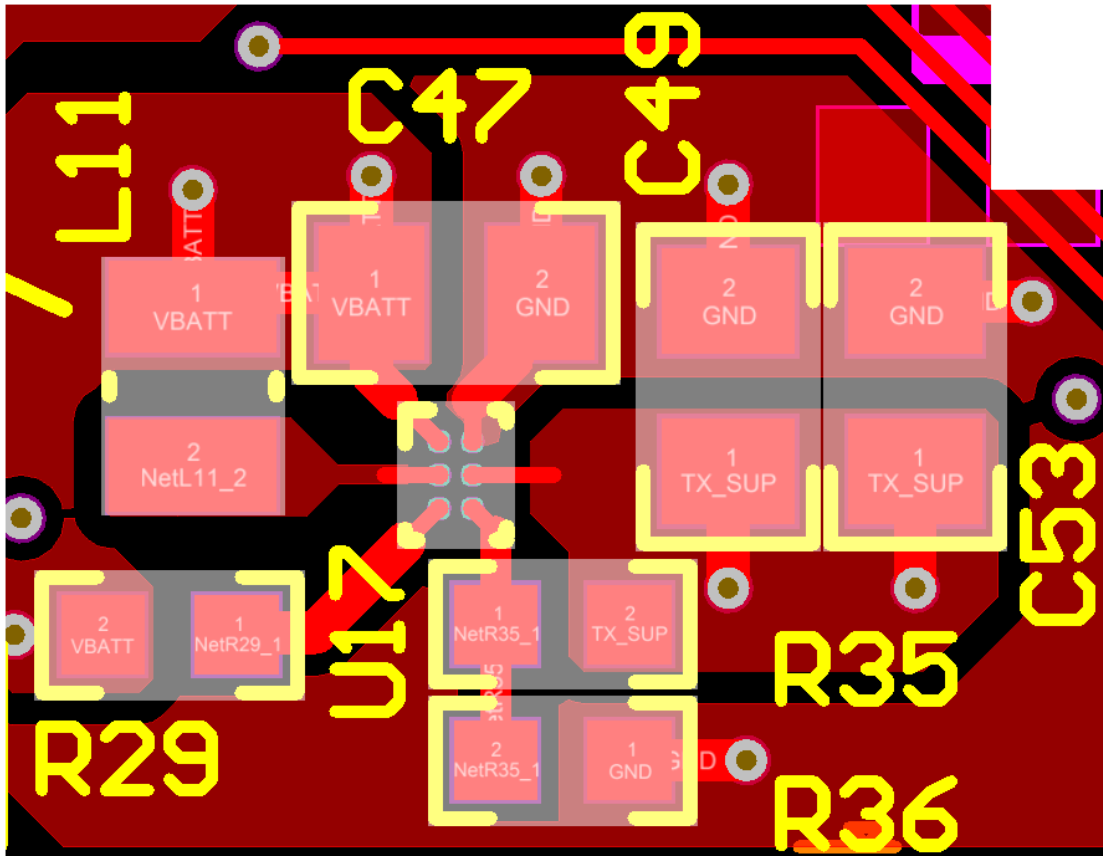

图 70. Layout and Traces for Buck-Boost Converter, TPS63036

4.3.9 Layouts for PPG Sensor Boards



图 71. Layout for SFH 7072 Board (Top Layer)

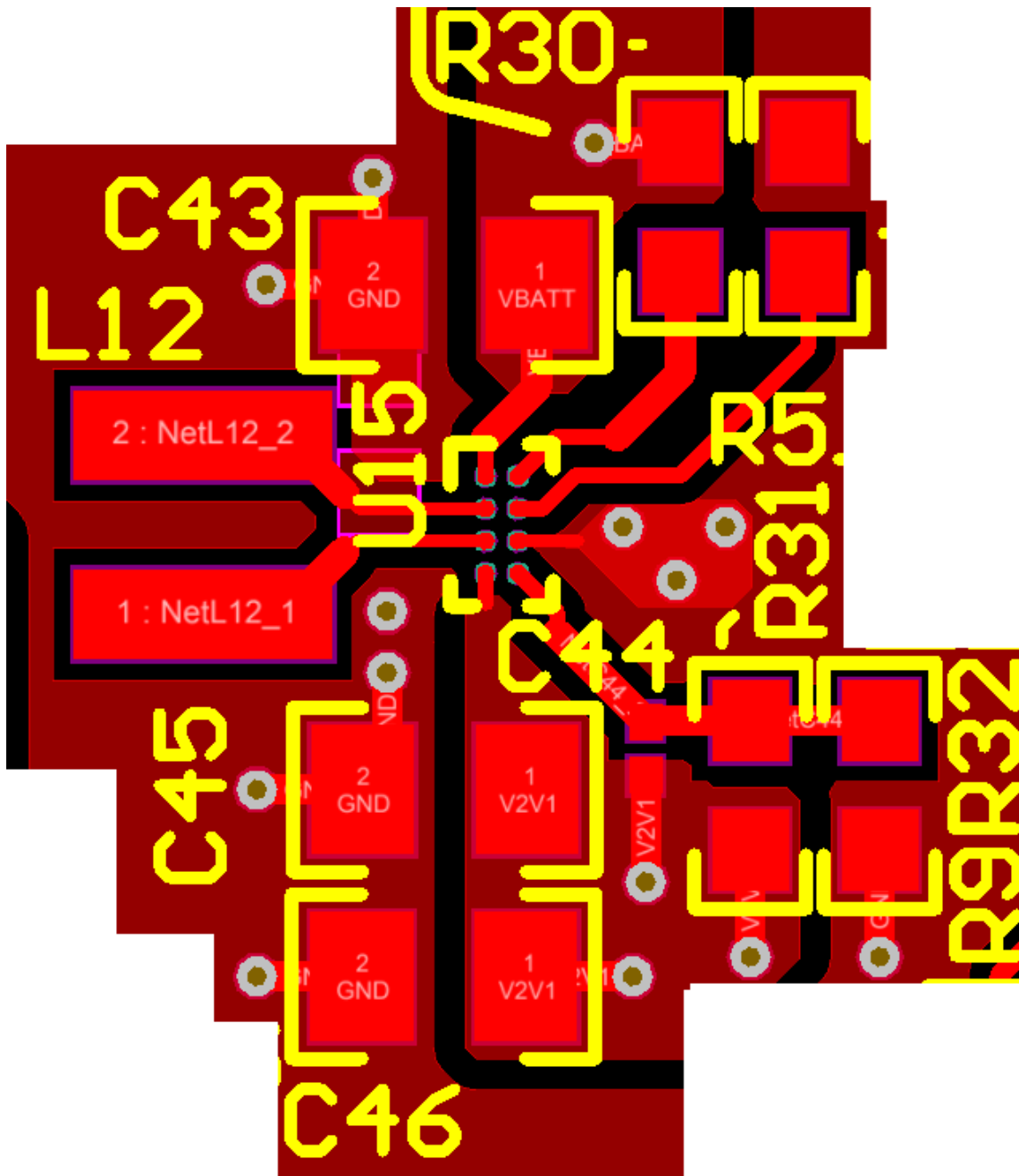

图 72. Layout for SFH 7072 Board (Bottom Layer)

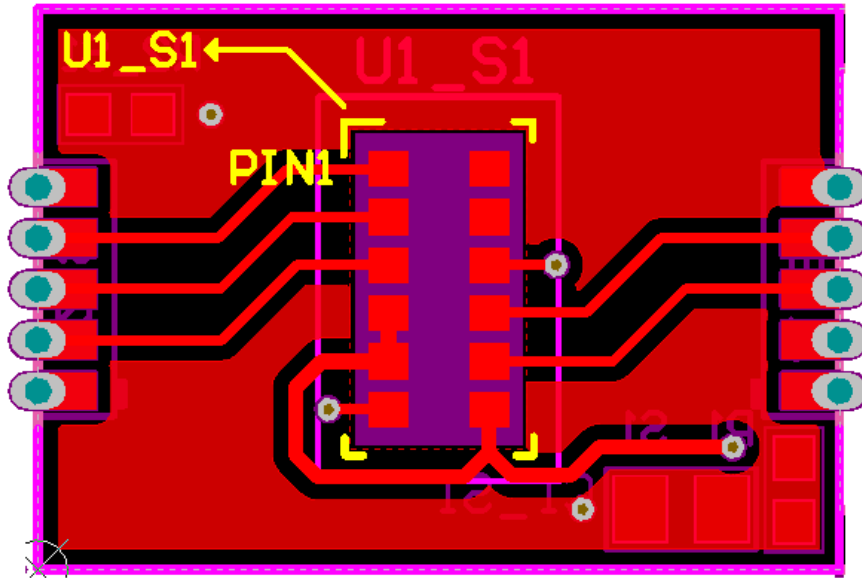

图 73. Layout for OCS112 Board (Top Layer)

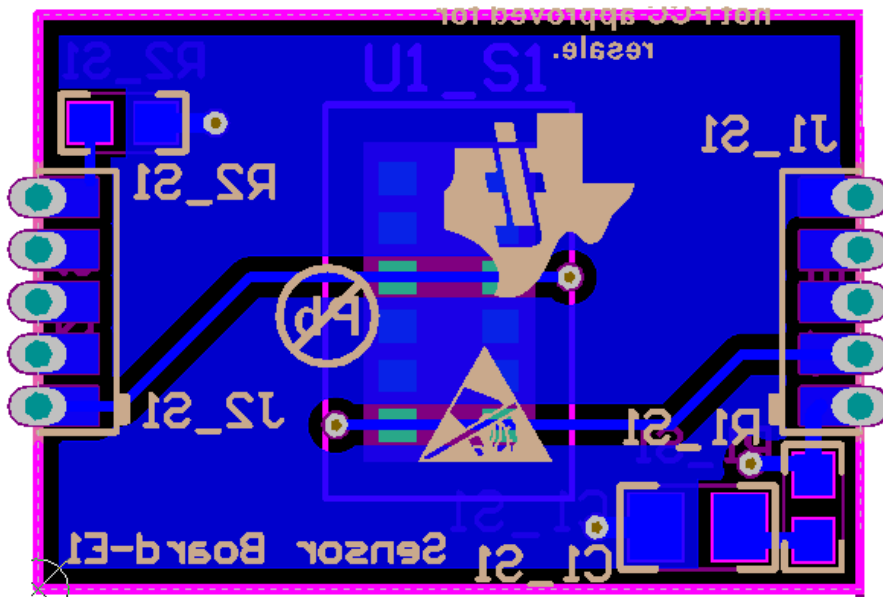

图 74. Layout for OCS112 Board (Bottom Layer)

4.3.10 Layout for ECG Sensor Board

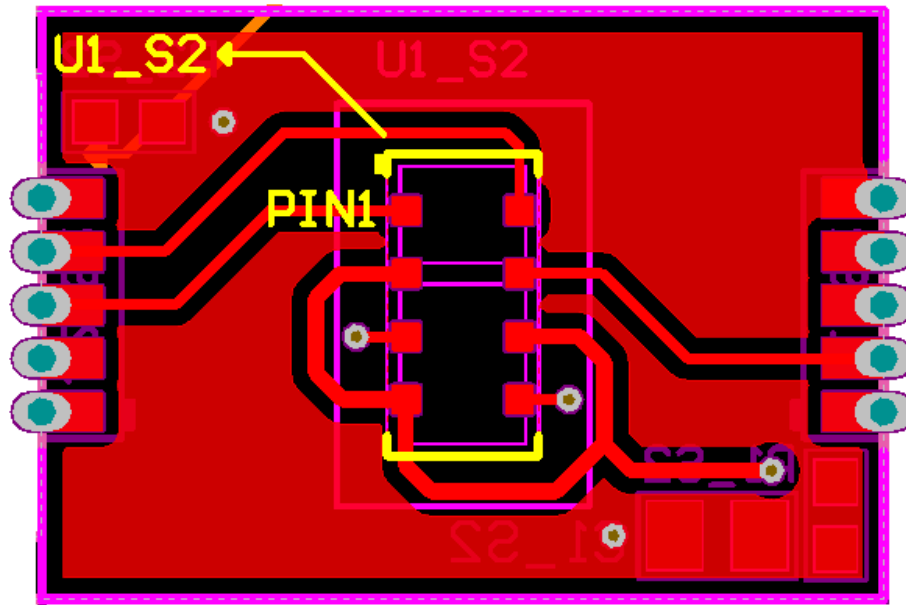

图 75. Layout for ECG Board (Top Layer)

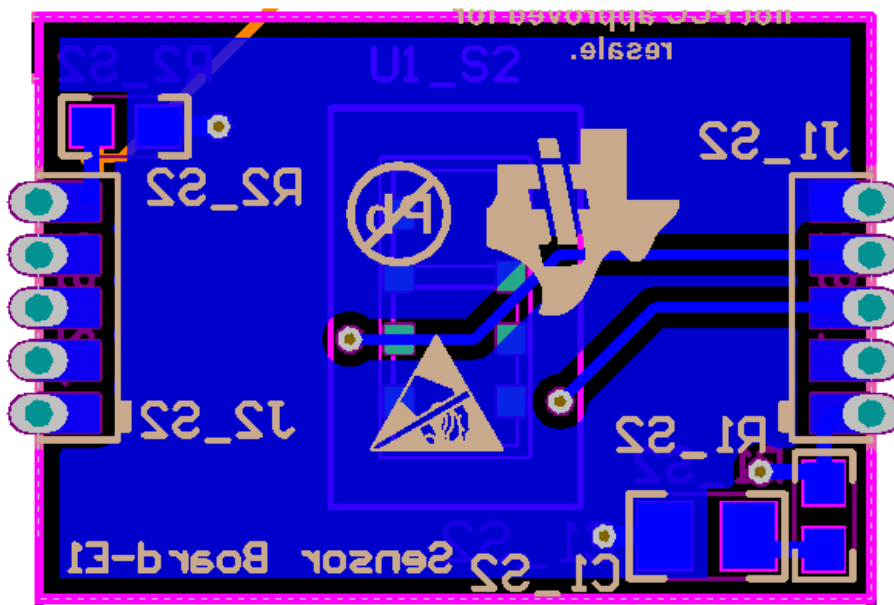

图 76. Layout for ECG Board (Bottom Layer)

4.3.11 Layout Prints

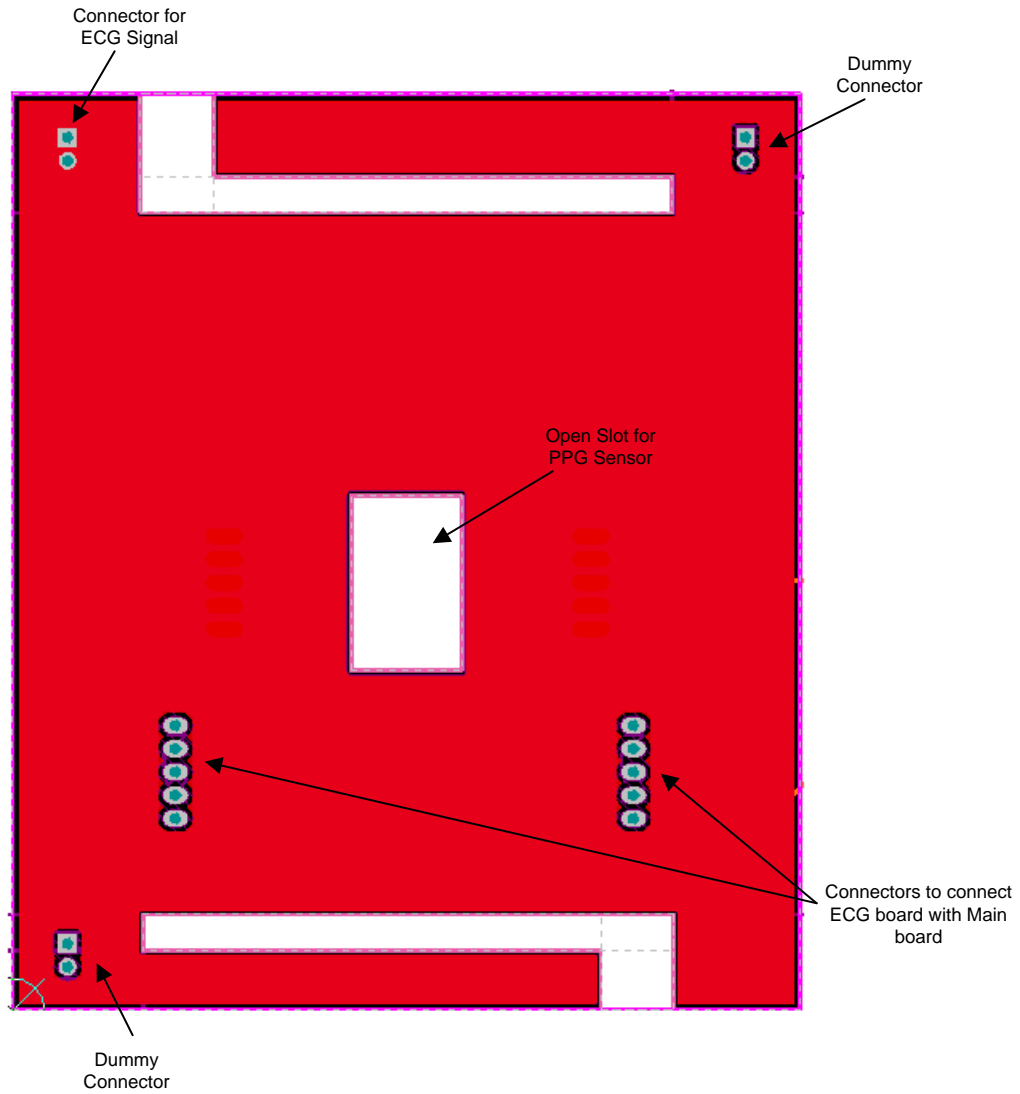
To download the layer plots, see the design files at [TIDA-01580](#).

4.4 Altium Project

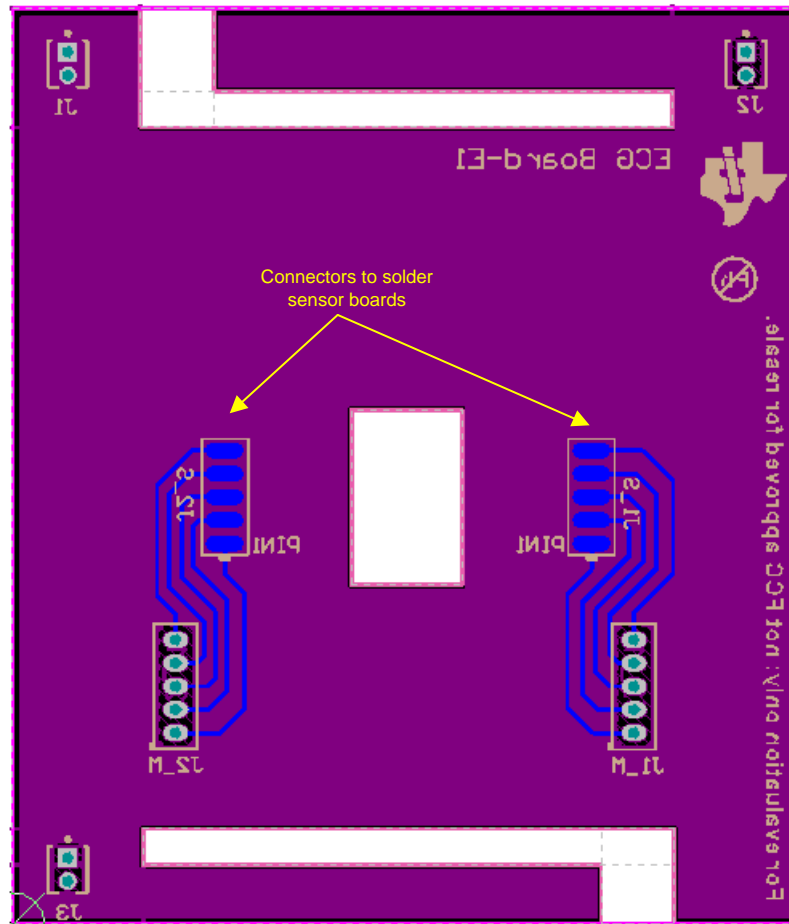
To download the Altium project files, see the design files at [TIDA-01580](#).

4.5 Gerber Files

To download the Gerber files, see the design files at [TIDA-01580](#).

4.6 Assembly Drawings

To download the assembly drawings, see the design files at [TIDA-01580](#).

5 Software Files

To download the software files, see the design files at [TIDA-01580](#).

6 Related Documentation

1. Texas Instruments, [TINA-TI Simulation Software](#)
2. Texas Instruments, [Miniaturized Pulse Oximeter Reference Design Getting Started Guide](#)
3. Texas Instruments, [How to Design Peripheral Oxygen Saturation \(SpO2\) and Optical Heart Rate Monitoring \(OHRM\) Systems Using the AFE4403](#), application report
4. Texas Instruments, [Understanding Lead-Off Detection in ECG](#), application report
5. Texas Instruments, [Measuring Bluetooth® Low Energy Power Consumption](#), application report
6. Texas Instruments, [Measuring Bluetooth Low Energy Power Consumption](#), application report

6.1 商标

E2E, SimpleLink, TINA-TI, Code Composer Studio are trademarks of Texas Instruments.

WEBENCH is a registered trademark of Texas Instruments.

Arm, Cortex are registered trademarks of Arm Limited.

Bluetooth is a registered trademark of Bluetooth SIG.

LabVIEW is a trademark of National Instruments.

OSRAM is a registered trademark of OSRAM Opto Semiconductors GmbH.

Wi-Fi is a registered trademark of Wi-Fi Alliance.

All other trademarks are the property of their respective owners.

7 About the Authors

SANJAY PITHADIA is a systems designer at Texas Instruments, where he is responsible for developing subsystem design solutions for the Medical Healthcare and Fitness sector. Sanjay has been with TI since 2008 and has been involved in designing reference designs related to energy, smart grid, industrial motor drives, and medical imaging. Sanjay brings to this role his experience in analog design, mixed signal design, industrial interfaces, and power supplies. Sanjay earned his bachelor of technology in electronics engineering at the Veermata Jijabai Technological Institute, Mumbai.

KIRAN RAJMOHAN is a test engineer at Texas Instruments, where he is responsible for testing and characterization of high-performance analog IPs like ADC, DAC, PGA, PLL, and RF-signal chains in TI microcontrollers. Kiran has been with TI since 2015. Kiran earned his bachelor of technology in electronics and communication engineering at the College of Engineering, Trivandrum, Kerala.

修订历史记录

注：之前版本的页码可能与当前版本有所不同。

Changes from Original (April 2018) to A Revision	Page
• 已更改 将标题从可穿戴无线多参数患者监护仪参考设计 更改为用于医疗和消费类可穿戴设备的无线 ECG、SpO2、PTT 和心率监护仪参考设计	1
• 已删除 从“应用”中删除了无线患者监护仪	1
• 已添加 向“应用”中添加了医疗传感器贴片、智能手表和智能追踪器	1
• 已添加 information to <i>ECG Measurement</i> section.....	15
• 已添加 information to <i>Three-Electrode Configuration</i> section.....	16
• 已更改 values in <i>Component Mounting for Two-Electrode and Three-Electrode Configurations (DC and AC Lead-Off Detection)</i> table	17

重要声明和免责声明

TI 均以“原样”提供技术性 & 可靠性数据（包括数据表）、设计资源（包括参考设计）、应用或其他设计建议、网络工具、安全信息和其他资源，不保证其中不含任何瑕疵，且不做任何明示或暗示的担保，包括但不限于对适销性、适合某特定用途或不侵犯任何第三方知识产权的暗示担保。

所述资源可供专业开发人员应用 TI 产品进行设计使用。您将对以下行为独自承担全部责任：(1) 针对您的应用选择合适的 TI 产品；(2) 设计、验证并测试您的应用；(3) 确保您的应用满足相应标准以及任何其他安全、安保或其他要求。所述资源如有变更，恕不另行通知。TI 对您使用所述资源的授权仅限于开发资源所涉及 TI 产品的相关应用。除此之外不得复制或展示所述资源，也不提供其它 TI 或任何第三方的知识产权授权许可。如因使用所述资源而产生任何索赔、赔偿、成本、损失及债务等，TI 对此概不负责，并且您须赔偿由此对 TI 及其代表造成的损害。

TI 所提供产品均受 TI 的销售条款 (<http://www.ti.com.cn/zh-cn/legal/termsofsale.html>) 以及 [ti.com.cn](http://www.ti.com.cn) 上或随附 TI 产品提供的其他可适用条款的约束。TI 提供所述资源并不扩展或以其他方式更改 TI 针对 TI 产品所发布的可适用的担保范围或担保免责声明。

邮寄地址：上海市浦东新区世纪大道 1568 号中建大厦 32 楼，邮政编码：200122
Copyright © 2019 德州仪器半导体技术（上海）有限公司

重要声明和免责声明

TI 均以“原样”提供技术性 & 可靠性数据（包括数据表）、设计资源（包括参考设计）、应用或其他设计建议、网络工具、安全信息和其他资源，不保证其中不含任何瑕疵，且不做任何明示或暗示的担保，包括但不限于对适销性、适合某特定用途或不侵犯任何第三方知识产权的暗示担保。

所述资源可供专业开发人员应用 TI 产品进行设计使用。您将对以下行为独自承担全部责任：(1) 针对您的应用选择合适的 TI 产品；(2) 设计、验证并测试您的应用；(3) 确保您的应用满足相应标准以及任何其他安全、安保或其他要求。所述资源如有变更，恕不另行通知。TI 对您使用所述资源的授权仅限于开发资源所涉及 TI 产品的相关应用。除此之外不得复制或展示所述资源，也不提供其它 TI 或任何第三方的知识产权授权许可。如因使用所述资源而产生任何索赔、赔偿、成本、损失及债务等，TI 对此概不负责，并且您须赔偿由此对 TI 及其代表造成的损害。

TI 所提供产品均受 TI 的销售条款 (<http://www.ti.com.cn/zh-cn/legal/termsofsale.html>) 以及 [ti.com.cn](http://www.ti.com.cn) 上或随附 TI 产品提供的其他可适用条款的约束。TI 提供所述资源并不扩展或以其他方式更改 TI 针对 TI 产品所发布的可适用的担保范围或担保免责声明。

邮寄地址：上海市浦东新区世纪大道 1568 号中建大厦 32 楼，邮政编码：200122
Copyright © 2019 德州仪器半导体技术（上海）有限公司