

OPA828 低失调电压、低漂移、低噪声 45MHz、36V JFET 输入、RRO 运算放大器

1 特性

- 低输入电压噪声密度：
1kHz 时为 $4\text{nV}/\sqrt{\text{Hz}}$
- 输入电压噪声：
0.1Hz 至 10Hz: 60nV_{RMS}
- 低输入偏置电流: 1pA
- 输入失调电压: $50\mu\text{V}$
- 输入温漂: $0.45\mu\text{V}/^\circ\text{C}$
- 支持多路复用器的输入
- 增益带宽: 45MHz
- 压摆率: $150\text{V}/\mu\text{s}$
- 14 位趋稳时间: 120ns
- 过载功率限制器
- 宽电源电压范围: $\pm 4\text{V}$ 至 $\pm 18\text{V}$
- 封装: 8 引脚 SOIC

2 应用

- 数据采集 (DAQ)
- 光学模块
- 地震测试设备
- 混合模块
- 超声波扫描仪

3 说明

OPA828 JFET 是下一代 OPA627 和 OPA827 运算放大器，集高速度与高直流精密、高交流性能于一体。该运算放大器可实现低失调电压 ($50\mu\text{V}$)、低温漂 ($0.45\mu\text{V}/^\circ\text{C}$ 典型值)、低偏置电流 (1pA 典型值) 和低噪声 ($4\text{nV}/\sqrt{\text{Hz}}$ 典型值)，噪声仅为 60nV_{RMS} 0.1Hz 至 10Hz。OPA828 在 $\pm 4\text{V}$ 至 $\pm 18\text{V}$ 的宽电源电压范围内工作，每通道电源电流仅为 5.5mA (典型值)。

交流特性 (包括 45MHz 增益带宽积 (GBW))、 $150\text{V}/\mu\text{s}$ 的压摆率和精密直流特性使得 OPA828 成为各种系统的理想选择。其中包括高速和高分辨率数据采集系统 (例如 16 位和 18 位混合信号系统)、跨阻 (I/V 转换) 放大器、滤波器、精密 $\pm 10\text{V}$ 前端和高阻抗传感器接口应用。

OPA828 器件可提供符合工业标准的 8 引脚 SOIC 表面贴装封装，额定工作温度范围为 -40°C 到 $+125^\circ\text{C}$ 。

器件信息⁽¹⁾

器件型号	封装	封装尺寸 (标称值)
OPA828	SOIC (8)	4.90mm x 3.91mm

(1) 如需了解所有可用封装，请参阅产品说明书末尾的可订购产品附录。

开环增益和相位与频率间的关系

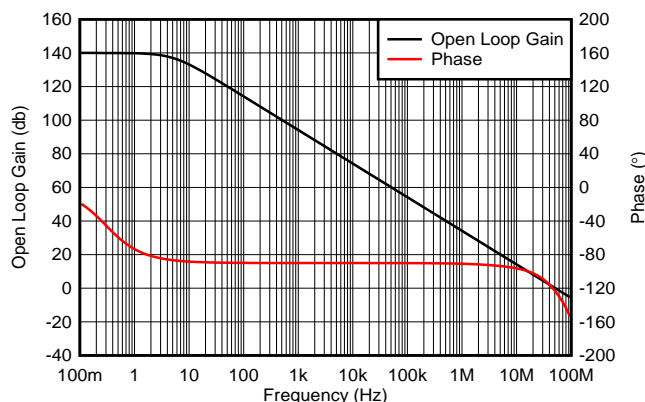

失调电压漂移

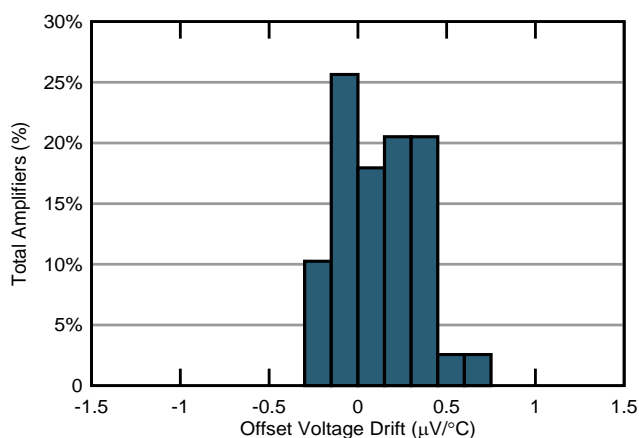

目录

1	特性	1	8	Application and Implementation	27
2	应用	1	8.1	Application Information.....	27
3	说明	1	8.2	Typical Applications	27
4	修订历史记录	2	9	Power Supply Recommendations	31
5	Pin Configuration and Functions	3	10	Layout	32
6	Specifications	4	10.1	Layout Guidelines	32
6.1	Absolute Maximum Ratings	4	10.2	Layout Example	33
6.2	ESD Ratings.....	4	11	器件和文档支持	34
6.3	Recommended Operating Conditions	4	11.1	器件支持	34
6.4	Thermal Information	4	11.2	文档支持	34
6.5	Electrical Characteristics	5	11.3	接收文档更新通知	34
6.6	Typical Characteristics	8	11.4	社区资源	34
7	Detailed Description	16	11.5	商标	34
7.1	Overview	16	11.6	静电放电警告	34
7.2	Functional Block Diagram	16	11.7	术语表	34
7.3	Feature Description.....	17	12	机械、封装和可订购信息	34
7.4	Device Functional Modes.....	26			

4 修订历史记录

注：之前版本的页码可能与当前版本有所不同。

Changes from Revision A (November 2018) to Revision B		Page
•	首次发布生产数据数据表	1

5 Pin Configuration and Functions

**D Package
8-Pin SOIC
Top View**

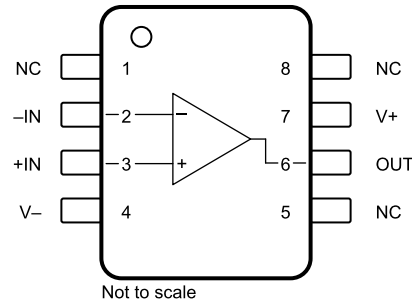

NC: no internal connection

Pin Functions

NAME	NO.	I/O	DESCRIPTION
-IN	2	I	Negative (inverting) input
+IN	3	I	Positive (non-inverting) input
NC	1, 5, 8	—	No internal connection (can be left floating or grounded)
OUT	6	O	Output
V+	7	—	Positive (highest) power supply
V-	4	—	Negative (lowest) power supply

6 Specifications

6.1 Absolute Maximum Ratings

over operating free-air temperature range (unless otherwise noted)⁽¹⁾

		MIN	MAX	UNIT	
Supply voltage, $V_S = (V+) - (V-)$	Single-supply		40	V	
	Dual-supply		±20		
Signal input pins	Voltage	Common-mode ⁽²⁾	(V-) – 0.5		(V+) + 0.5
		Differential ⁽³⁾			(V+) – (V-)
	Current ⁽²⁾			±10	mA
Output short current ⁽⁴⁾			Continuous		
Temperature	Junction, T_J	-55	150	°C	
	Storage, T_{stg}	-65	150		

- (1) Stresses beyond those listed under *Absolute Maximum Ratings* may cause permanent damage to the device. These are stress ratings only, which do not imply functional operation of the device at these or any other conditions beyond those indicated under *Recommended Operating Ratings*. Exposure to absolute-maximum-rated conditions for extended periods may affect device reliability.
- (2) Input terminals are diode-clamped to the power-supply rails. Current-limit input signals that can swing more than 0.5 V beyond the supply rails to 10 mA or less.
- (3) Input terminals are not clamped to each other with anti-parallel diodes. The JFET input stage allows large differential voltage values up to the supply voltage of the device.
- (4) Short circuit to ground, one amplifier per package.

6.2 ESD Ratings

		VALUE	UNIT	
$V_{(ESD)}$	Electrostatic discharge	Human body model (HBM), per ANSI/ESDA/JEDEC JS-001, all pins ⁽¹⁾	±2000	V
		Charged device model (CDM), per JEDEC specification JESD22-C101, all pins ⁽²⁾	±500	

- (1) JEDEC document JEP155 states that 500-V HBM allows safe manufacturing with a standard ESD control process.
- (2) JEDEC document JEP157 states that 250-V CDM allows safe manufacturing with a standard ESD control process.

6.3 Recommended Operating Conditions

over operating free-air temperature range (unless otherwise noted)

		MIN	NOM	MAX	UNIT
V_S	Supply voltage, (V+) – (V-)	Single supply	8	36	V
		Dual supply	±4	±18	
	Ambient temperature	-40		125	°C

6.4 Thermal Information

THERMAL METRIC ⁽¹⁾		OPA828	UNIT
		D (SOIC)	
		8 PINS	
$R_{\theta JA}$	Junction-to-ambient thermal resistance	121.5	°C/W
$R_{\theta JC(top)}$	Junction-to-case (top) thermal resistance	64.3	°C/W
$R_{\theta JB}$	Junction-to-board thermal resistance	65	°C/W
Ψ_{JT}	Junction-to-top characterization parameter	18	°C/W
Ψ_{JB}	Junction-to-board characterization parameter	64.3	°C/W

- (1) For more information about traditional and new thermal metrics, see the [Semiconductor and IC Package Thermal Metrics](#) application report.

6.5 Electrical Characteristics

At $T_A = 25^\circ\text{C}$, $(V+) = 15\text{ V}$, $(V-) = -15\text{ V}$, $V_{CM} = V_O = \text{midsupply}$, $C_L = 20\text{ pF}$, $R_L = 2\text{ k}\Omega$ connected to midsupply, unless otherwise noted.

PARAMETER		TEST CONDITIONS		MIN	TYP	MAX	UNIT	
OFFSET VOLTAGE								
V_{OS}	Input offset voltage				± 50	± 300	μV	
		$T_A = 0^\circ\text{C to } 85^\circ\text{C}$				± 350		
		$T_A = -40^\circ\text{C to } 125^\circ\text{C}$				± 400		
dV_{OS}/dT	Input offset voltage drift	$T_A = 0^\circ\text{C to } 85^\circ\text{C}$			± 0.3	± 1.3	$\mu\text{V}/^\circ\text{C}$	
		$T_A = -40^\circ\text{C to } 125^\circ\text{C}$			± 0.45	± 1.5		
PSRR	Power-supply rejection ratio	$8\text{ V} \leq V_S \leq 36\text{ V}$				1.4	± 5.6	$\mu\text{V}/\text{V}$
			$T_A = -0^\circ\text{C to } 85^\circ\text{C}$				± 7	
			$T_A = -40^\circ\text{C to } 125^\circ\text{C}$				± 10	
INPUT BIAS CURRENT								
I_B	Input bias current				± 1	± 8	pA	
		$T_A = 0^\circ\text{C to } 85^\circ\text{C}$				± 400		
		$T_A = -40^\circ\text{C to } 125^\circ\text{C}$				± 3		
I_{OS}	Input offset current				± 1	± 8	pA	
		$T_A = 0^\circ\text{C to } 85^\circ\text{C}$				± 500		
		$T_A = -40^\circ\text{C to } 125^\circ\text{C}$				± 1.5		
NOISE								
E_N	Input voltage noise	$f = 0.1\text{ Hz to } 10\text{ Hz, peak-to-peak}$			0.34		μV_{PP}	
		$f = 0.1\text{ Hz to } 10\text{ Hz, RMS}$			0.06		μV_{RMS}	
e_N	Input voltage noise density	$f = 10\text{ Hz}$			7.5		$\text{nV}/\sqrt{\text{Hz}}$	
		$f = 100\text{ Hz}$			4.8			
		$f = 1\text{ kHz}$			4			
i_N	Input current noise density	$f = 1\text{ kHz}$			1.2		$\text{fA}/\sqrt{\text{Hz}}$	
INPUT VOLTAGE								
V_{CM}	Common-mode voltage range			$(V-) + 2.5$		$(V+) - 3.5$	V	
CMRR	Common-mode rejection ratio	$(V-) + 2.5\text{ V} < V_{CM} < (V+) - 3.5\text{ V}$			108	115	dB	
				$T_A = 0^\circ\text{C to } 85^\circ\text{C}$	105			
				$T_A = -40^\circ\text{C to } 125^\circ\text{C}$	103			
INPUT IMPEDANCE								
Z_{ID}	Differential				$10^{12} \parallel 6$		$\Omega \parallel \text{pF}$	
Z_{ICM}	Common-mode				$10^{12} \parallel 9$		$\Omega \parallel \text{pF}$	

Electrical Characteristics (continued)

At $T_A = 25^\circ\text{C}$, $(V+) = 15\text{ V}$, $(V-) = -15\text{ V}$, $V_{\text{CM}} = V_O = \text{midsupply}$, $C_L = 20\text{ pF}$, $R_L = 2\text{ k}\Omega$ connected to midsupply, unless otherwise noted.

PARAMETER		TEST CONDITIONS		MIN	TYP	MAX	UNIT
OPEN-LOOP GAIN							
A_{OL}	Open-loop voltage gain	$(V-) + 1.6\text{ V} < V_O < (V+) - 1.6\text{ V}$, $R_L = 600\ \Omega$		120	130		dB
		$(V-) + 1.5\text{ V} < V_O < (V+) - 1.5\text{ V}$, $R_L = 10\text{ k}\Omega$		120	130		
		$T_A = -0^\circ\text{C}$ to 85°C	$(V-) + 1.6\text{ V} < V_O < (V+) - 1.6\text{ V}$, $R_L = 600\ \Omega$	117			
			$(V-) + 1.5\text{ V} < V_O < (V+) - 1.5\text{ V}$, $R_L = 10\text{ k}\Omega$	118			
		$T_A = -40^\circ\text{C}$ to 125°C	$(V-) + 1.6\text{ V} < V_O < (V+) - 1.6\text{ V}$, $R_L = 600\ \Omega$	114			
			$(V-) + 1.5\text{ V} < V_O < (V+) - 1.5\text{ V}$, $R_L = 10\text{ k}\Omega$	114			
FREQUENCY RESPONSE							
	Unity gain frequency	$V_O = 10\text{ mV}_{\text{PP}}$, $C_L = 30\text{ pF}$			45		MHz
	Phase margin	$V_O = 10\text{ mV}_{\text{PP}}$, $C_L = 30\text{ pF}$			57		Degrees
GBW	Gain-bandwidth product	$V_O = 10\text{ mV}_{\text{PP}}$, $C_L = 30\text{ pF}$			45		MHz
SR	Slew rate	$V_O = 10\text{-V}$ step	$G = +1$		150		V/ μs
			$G = -1$		150		
t_s	Settling time (input to output)	$V_O = 10\text{-V}$ step, $C_L = 30\text{ pF}$, $G = -1$	$T_o \pm 0.0244\%$ (12-bit accuracy)		110		ns
			$T_o \pm 0.0061\%$ (14-bit accuracy)		120		
	Overshoot	$V_O = 100\text{-mV}$ step, $G = +1$, $C_L = 30\text{ pF}$	$V_O = 100\text{-mV}$ step, $G = +1$, $C_L = 30\text{ pF}$		8%		
	Overload recovery time	$G = -10$			55		ns
	Total harmonic distortion + noise (THD+N)	$V_O = 3.5\text{ V}_{\text{RMS}}$, $G = +1$, $f = 1\text{ kHz}$	$R_L = 10\text{ k}\Omega$		0.000028%		dB
					-130		
			$R_L = 600\ \Omega$		0.000028%		dB
					-130		
HD2	Second-order harmonic distortion	$V_O = 5\text{ V}_{\text{PP}}$, $G = +1$	$f = 100\text{ kHz}$		119		dBc
			$f = 500\text{ kHz}$		90		
HD3	Third-order harmonic distortion	$V_O = 5\text{ V}_{\text{PP}}$, $G = +1$	$f = 100\text{ kHz}$		125		dBc
			$f = 500\text{ kHz}$		105		
IMD	Second-order intermodulation distortion	SMPTE/DIN two-tone, 4:1 (60 Hz and 7 kHz), $G = 1$, $V_O = 3\text{ V}_{\text{RMS}}$, $R_L = 2\text{ k}\Omega$, 90-kHz measurement bandwidth			132		dB
	Third-order intermodulation distortion	CCIF twin-tone (19 kHz and 20 kHz), $G = 1$, $V_O = 3\text{ V}_{\text{RMS}}$, $R_L = 2\text{ k}\Omega$, 90-kHz measurement bandwidth			137		dB

Electrical Characteristics (continued)

At $T_A = 25^\circ\text{C}$, $(V+) = 15\text{ V}$, $(V-) = -15\text{ V}$, $V_{CM} = V_O = \text{midsupply}$, $C_L = 20\text{ pF}$, $R_L = 2\text{ k}\Omega$ connected to midsupply, unless otherwise noted.

PARAMETER		TEST CONDITIONS		MIN	TYP	MAX	UNIT	
OUTPUT								
	Output voltage swing	$R_L = 10\text{ k}\Omega$			0.9	1.2	V	
		$R_L = 600\ \Omega$			1.2			
I_O	Output current	For linear operation, $A_{OL} \geq 120\text{ dB}$			± 30		mA	
I_{SC}	Short-circuit current				± 50		mA	
C_L	Capactive load drive				See Typical Curves		pF	
Z_O	Open-loop output impedance	$f = 1\text{ MHz}$, $I_O = 0\text{ mA}$			13.5		Ω	
POWER SUPPLY								
V_S	Specified voltage			± 4		± 18	V	
I_Q	Quiescent current (per amplifier)	$I_O = 0\text{ A}$			5.5	6.2	mA	
		$I_O = 0\text{ A}$	$T_A = 0^\circ\text{C to } 85^\circ\text{C}$				7.1	mA
			$T_A = -40^\circ\text{C to } 125^\circ\text{C}$				7.9	mA
TEMPERATURE RANGE								
T_A	Operating ambient temperature			-40		125	$^\circ\text{C}$	

6.6 Typical Characteristics

表 1. Table of Graphs

DESCRIPTION	FIGURE
Input Voltage Noise Density vs Frequency	图 1
. Integrated Input Voltage Noise vs Bandwidth	图 2
Total Harmonic Distortion + Noise Ratio vs Frequency	图 3
Total Harmonic Distortion + Noise Ratio vs Output Amplitude	图 4
. 0.1-Hz To 10-Hz Noise	图 5
Offset Voltage Production Distribution	图 6
Offset Voltage Drift Production Distribution	图 7
Offset Voltage vs Common-Mode Voltage	图 8
Offset Voltage vs Power Supply Voltage	图 9
Offset Voltage vs Output Voltage	图 10
. Offset Voltage vs Temperature	图 11
Input Bias and Input Offset Current vs Common-Mode Voltage	图 12
Input Bias and Input Offset Current vs Temperature	图 13
Quiescent Current vs Output Voltage	图 14
Quiescent Current vs Temperature	图 15
Output Voltage Swing vs Output Sourcing Current	图 16
Output Voltage Swing vs Output Sinking Current	图 17
Power-Supply Rejection Ratio vs Frequency	图 18
Common-Mode Rejection Ratio vs Frequency	图 19
Power-Supply Rejection Ratio vs Temperature	图 20
Common-Mode Rejection Ratio vs Temperature	图 21
Open-Loop Gain and Phase vs Frequency	图 22
Closed-Loop Gain vs Frequency	图 23
Open-Loop Gain vs Temperature	图 24
Open-Loop Output Impedance vs Frequency	图 25
Small-Signal Overshoot vs Capacitive Load, Gain = +1	图 26
Small-Signal Overshoot vs Capacitive Load, Gain = -1	图 27
No Phase Reversal	图 28
Positive Overload Recovery	图 29
Negative Overload Recovery	图 30
. Small-Signal Step Response	图 31
Large-Signal Step Response	图 32
12-bit, 14-bit Settling Time	图 33
Short-Circuit Current vs Temperature	图 35
Slew Rate vs Temperature	图 36
Slew Rate vs Output Step Size	图 37
Maximum Output Voltage vs Frequency	图 38
Intermodulation Distortion	图 39
Electromagnetic Interference Rejection	图 40
Harmonic Distortion vs Frequency	图 41

At $T_A = 25^\circ\text{C}$, $R_L = 2\text{ k}\Omega$ connected to midsupply, and $V_{CM} = V_{OUT} = \text{midsupply}$, $V_S = \pm 18\text{V}$, unless otherwise noted.



图 1. Input Voltage Noise Density vs Frequency



图 2. Integrated Input Voltage Noise vs Bandwidth

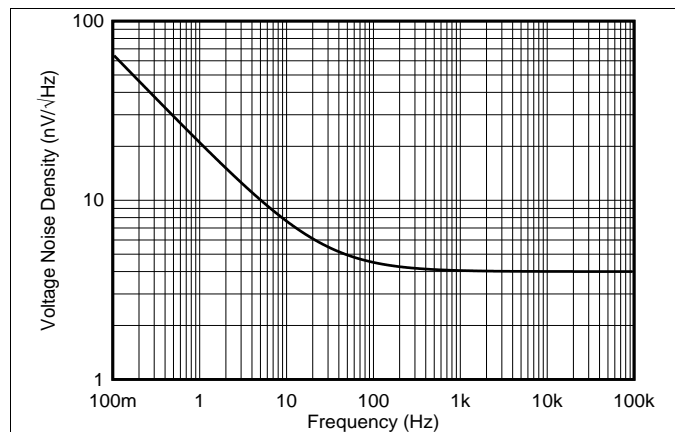

图 3. Total Harmonic Distortion + Noise Ratio vs Frequency

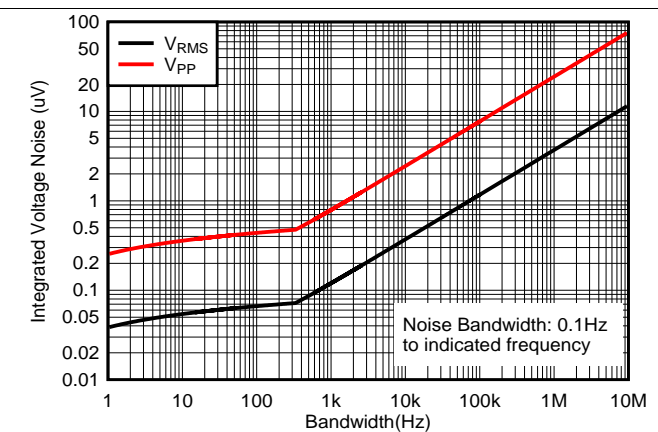

图 4. Total Harmonic Distortion + Noise Ratio vs Output Amplitude

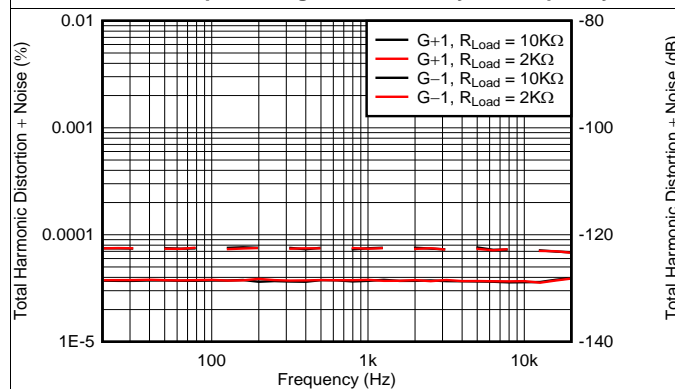

图 5. 0.1-Hz To 10-Hz Noise

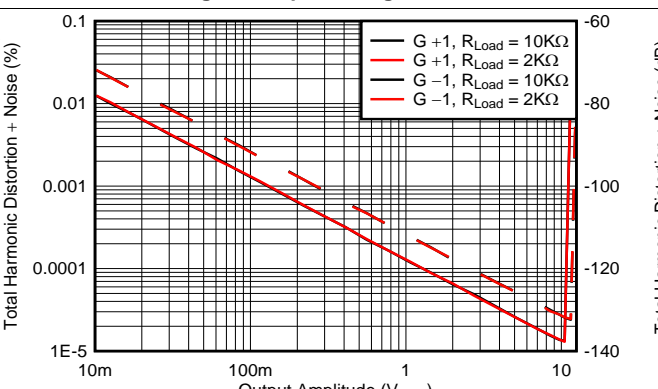

图 6. Offset Voltage Production Distribution

At $T_A = 25^\circ\text{C}$, $R_L = 2\text{ k}\Omega$ connected to midsupply, and $V_{CM} = V_{OUT} = \text{midsupply}$, $V_s = \pm 18\text{V}$, unless otherwise noted.

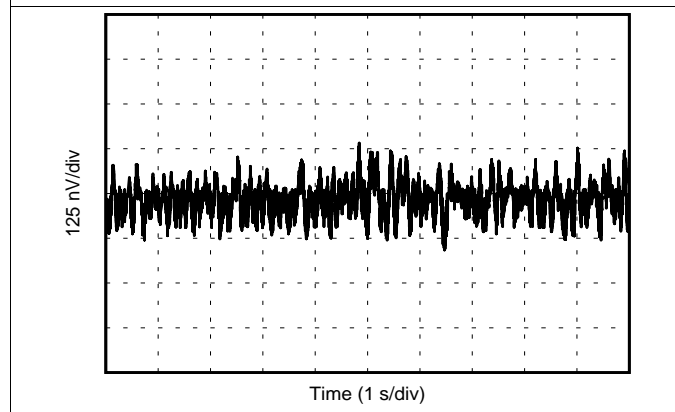

At $T_A = 25^\circ\text{C}$, $R_L = 2\text{ k}\Omega$ connected to midsupply, and $V_{CM} = V_{OUT} = \text{midsupply}$, $V_s = \pm 18\text{V}$, unless otherwise noted.

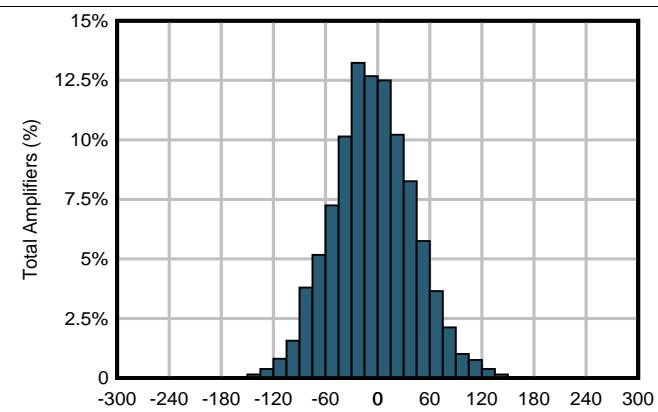
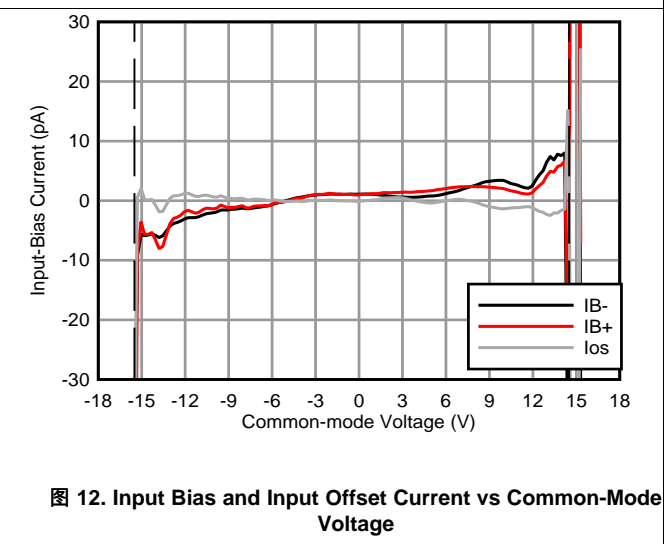
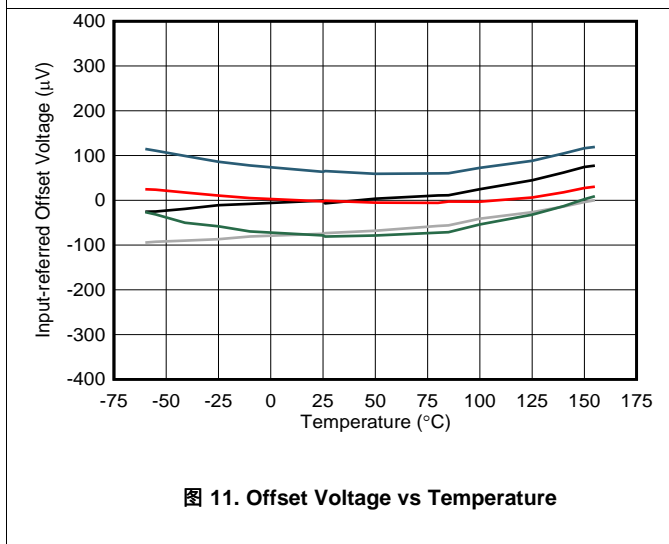
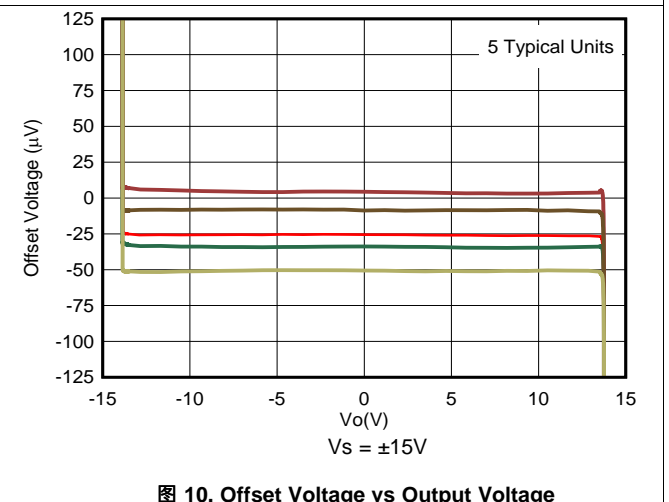
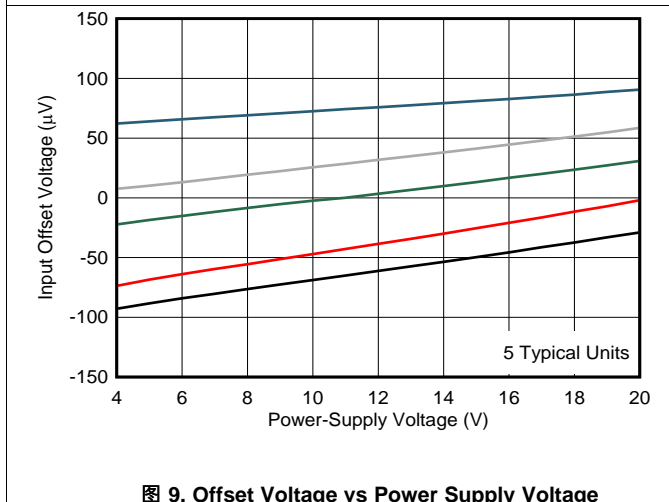
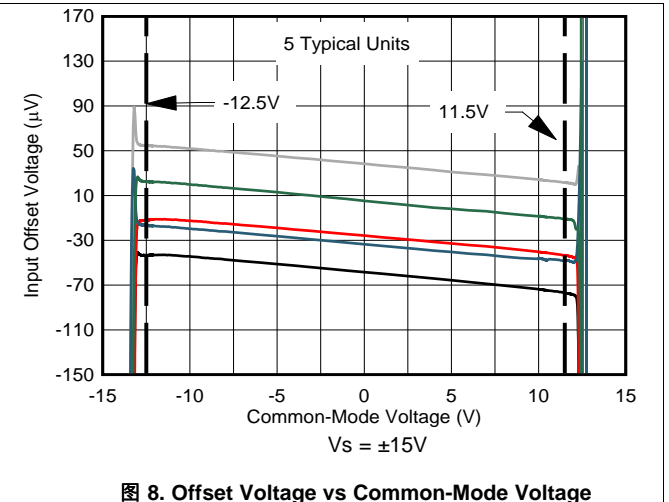
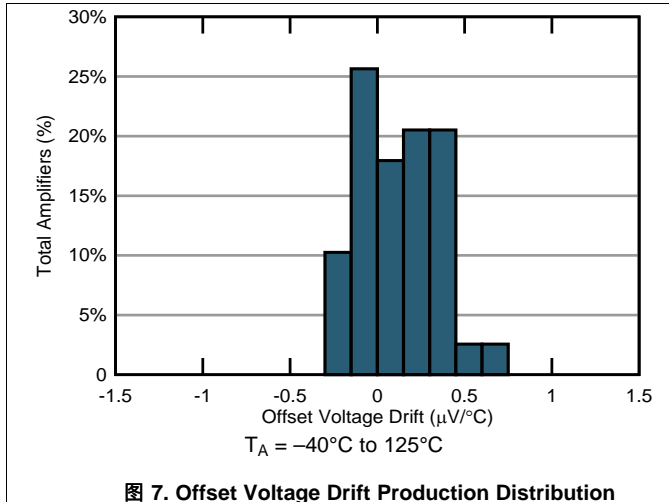

图 13. Input Bias and Input Offset Current vs Temperature



图 14. Quiescent Current vs Output Voltage

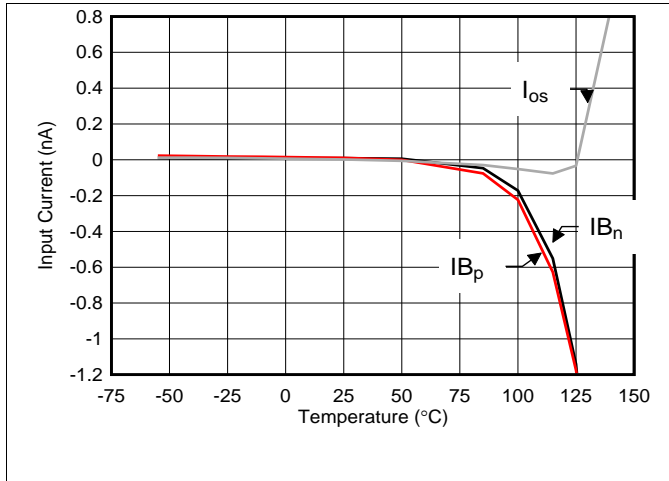

图 15. Quiescent Current vs Temperature

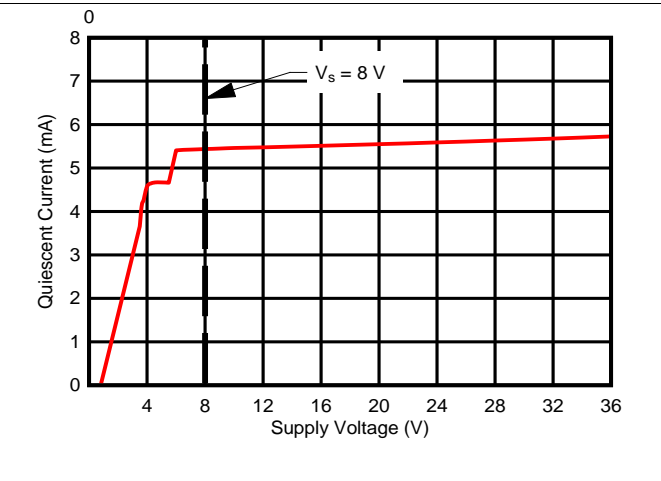

图 16. Output Voltage Swing vs Output Sourcing Current

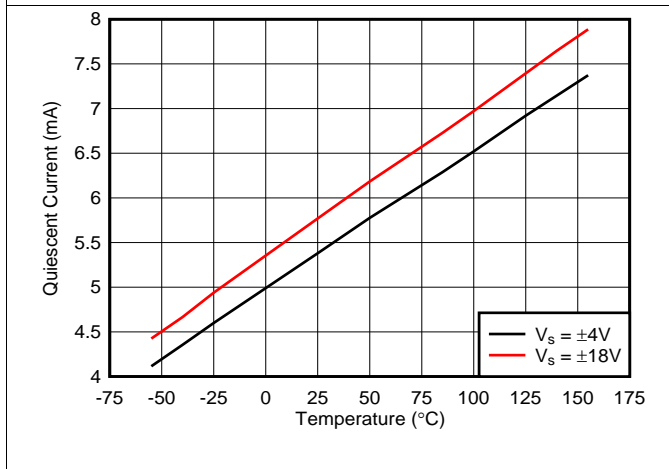

图 17. Output Voltage Swing vs Output Sinking Current

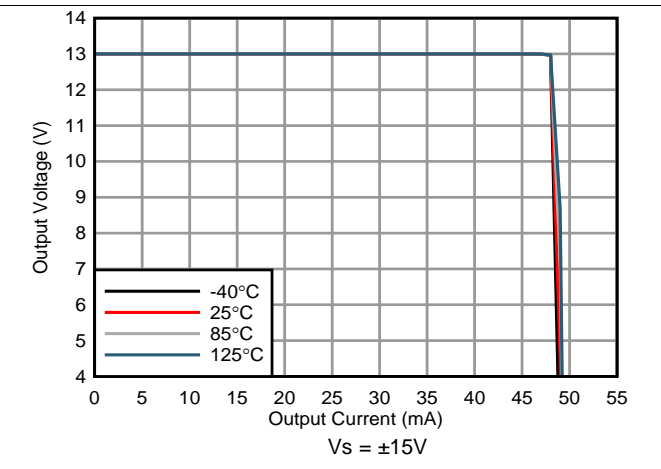

图 18. Power-Supply Rejection Ratio vs Frequency

At $T_A = 25^\circ\text{C}$, $R_L = 2\text{ k}\Omega$ connected to midsupply, and $V_{CM} = V_{OUT} = \text{midsupply}$, $V_s = \pm 18\text{V}$, unless otherwise noted.

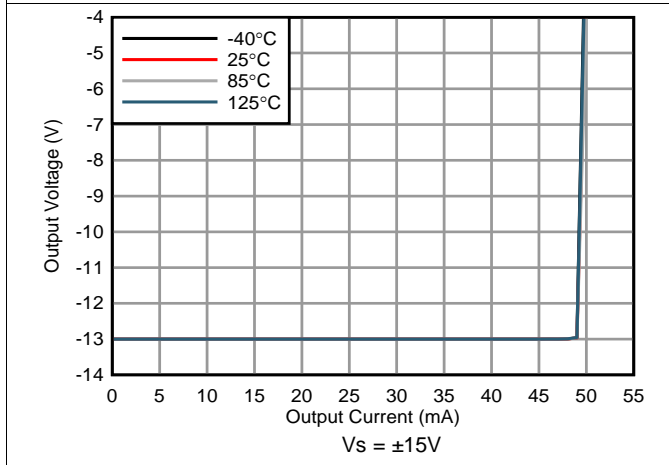

At $T_A = 25^\circ\text{C}$, $R_L = 2\text{ k}\Omega$ connected to midsupply, and $V_{CM} = V_{OUT} = \text{midsupply}$, $V_s = \pm 18\text{V}$, unless otherwise noted.

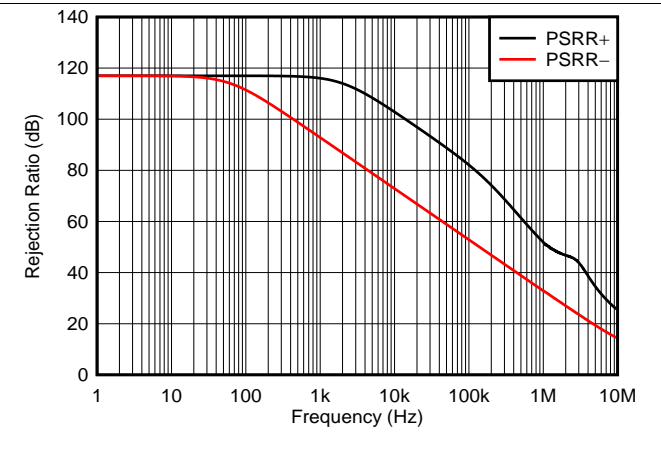
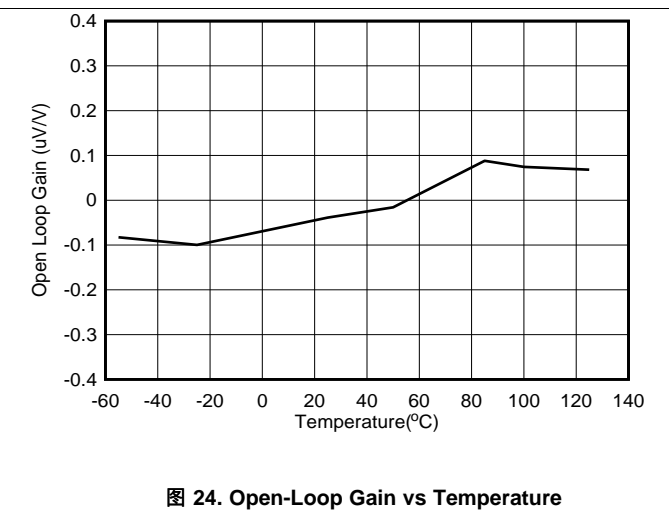
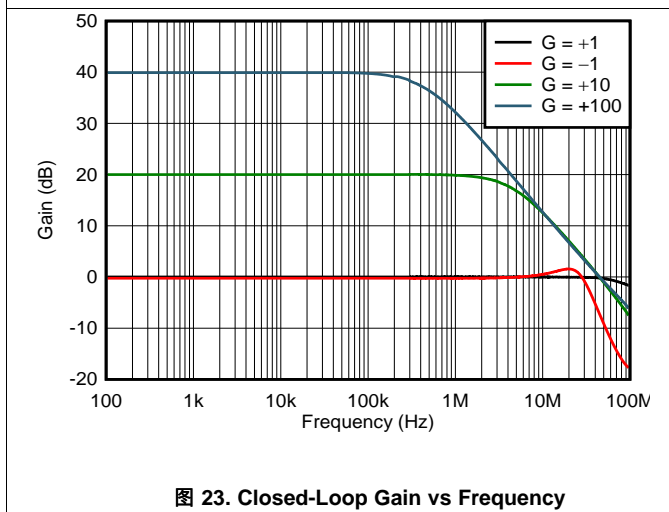
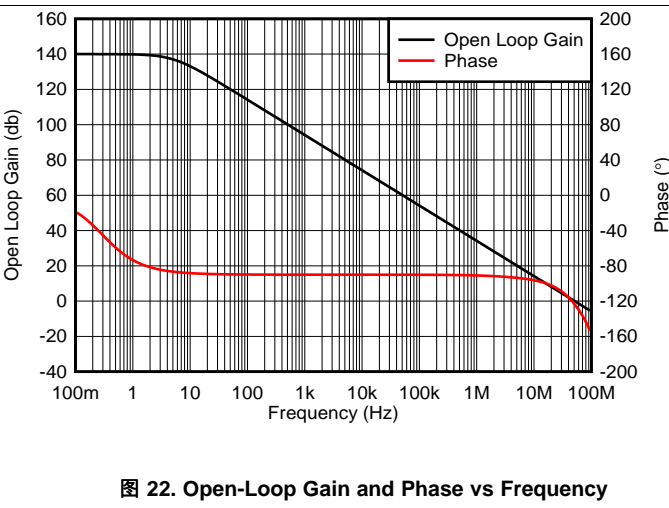
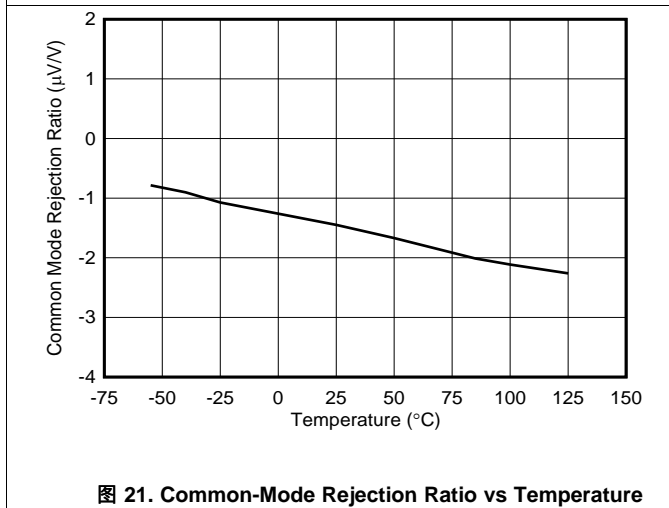
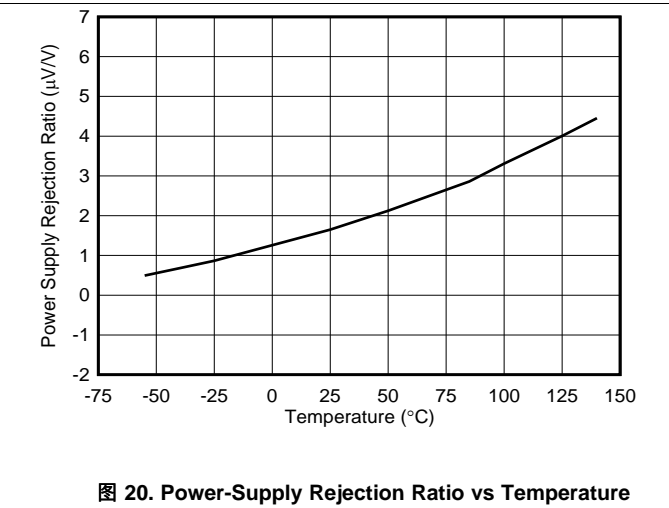
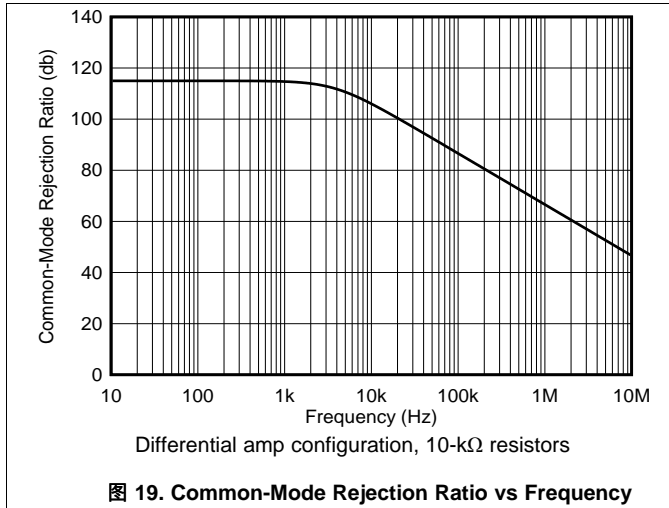

图 25. Open-Loop Output Impedance vs Frequency



图 26. Small-Signal Overshoot vs Capacitive Load, Gain = +1

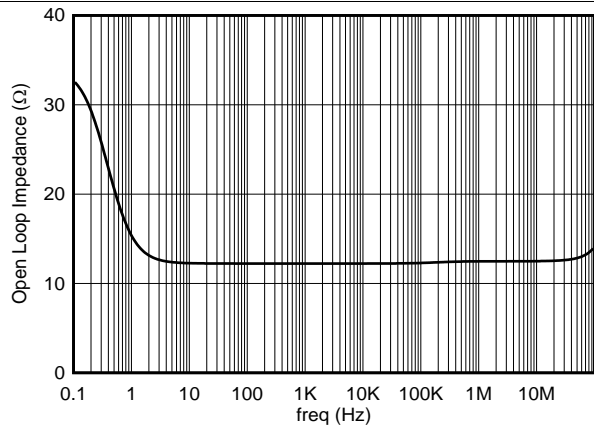

图 27. Small-Signal Overshoot vs Capacitive Load, Gain = -1

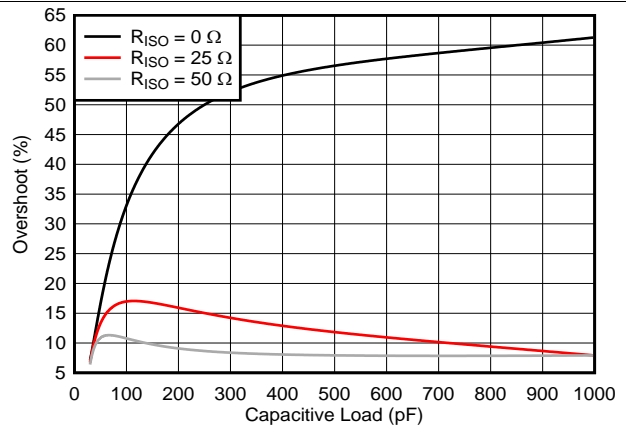

图 28. No Phase Reversal

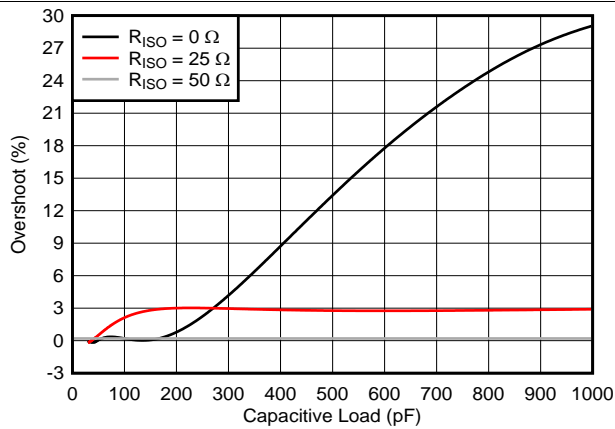

图 29. Positive Overload Recovery

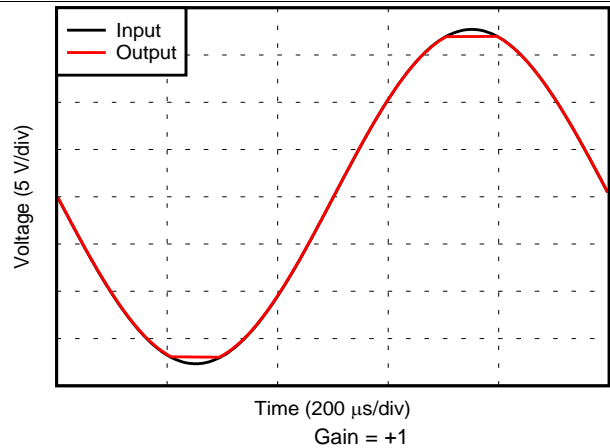

图 30. Negative Overload Recovery

At $T_A = 25^\circ\text{C}$, $R_L = 2\text{ k}\Omega$ connected to midsupply, and $V_{CM} = V_{OUT} = \text{midsupply}$, $V_s = \pm 18\text{V}$, unless otherwise noted.

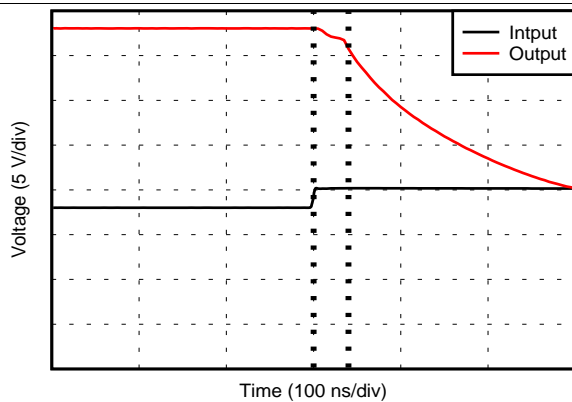

图 31. Small-Signal Step Response

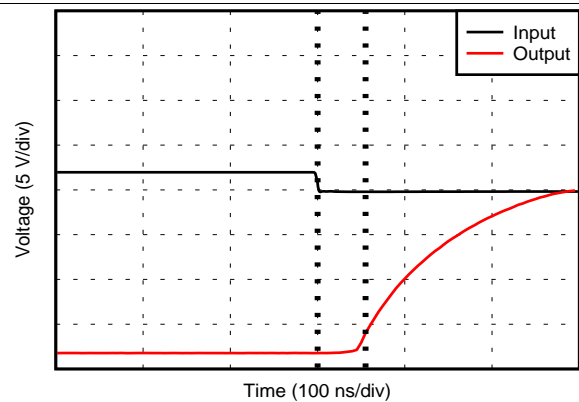

图 32. Large-Signal Step Response

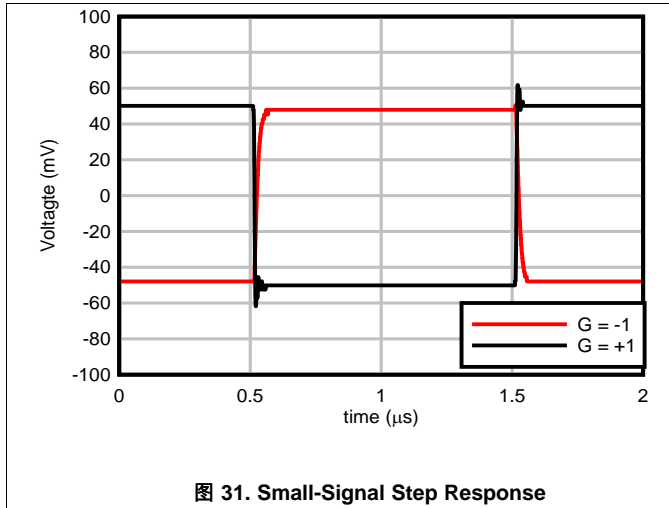

图 33. 12-bit Settling Time

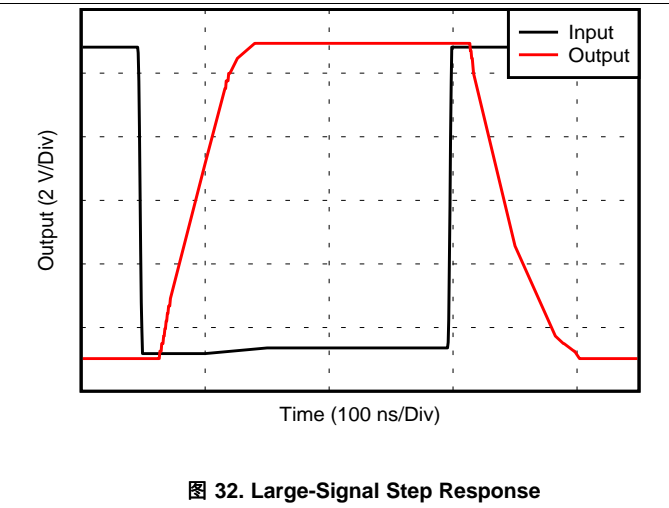

图 34. 14-bit Settling Time

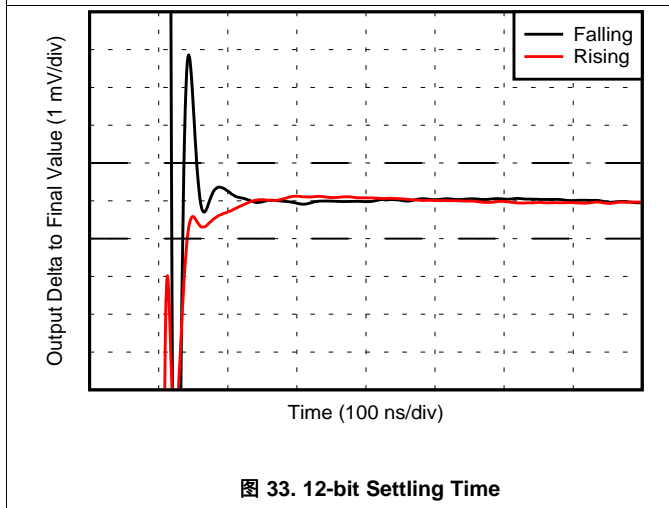

图 35. Short-Circuit Current vs Temperature

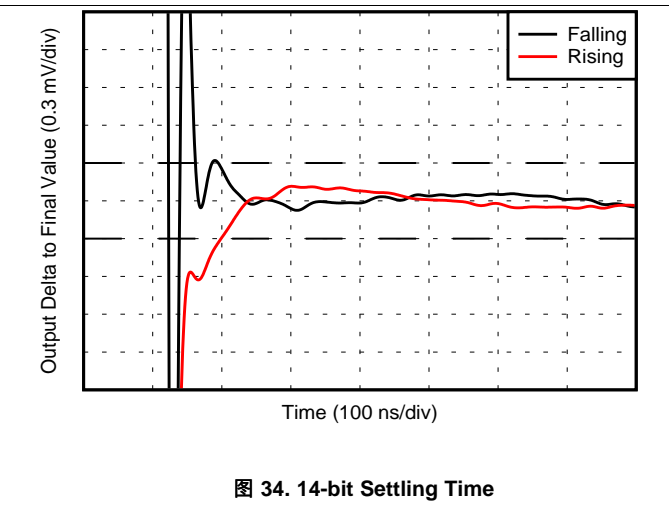

图 36. Slew Rate vs Temperature

At $T_A = 25^\circ\text{C}$, $R_L = 2\text{ k}\Omega$ connected to midsupply, and $V_{CM} = V_{OUT} = \text{midsupply}$, $V_S = \pm 18\text{V}$, unless otherwise noted.

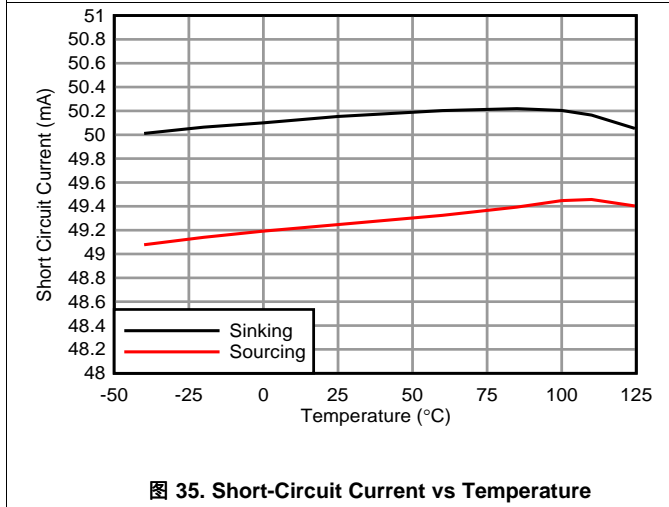

图 37. Slew Rate vs Output Step Size

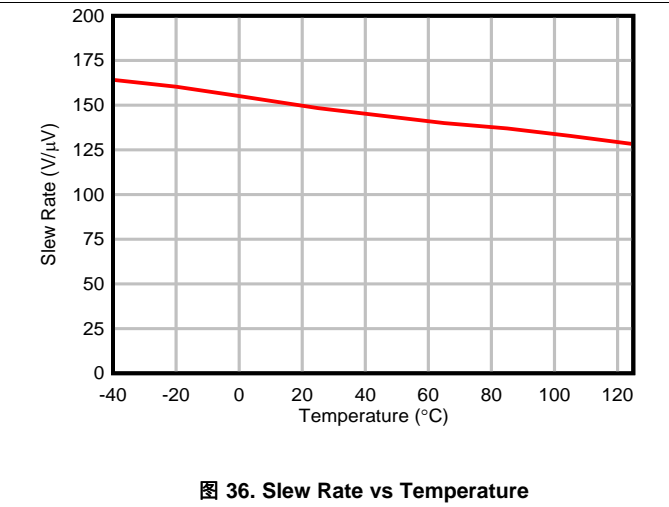

图 38. Maximum Output Voltage vs Frequency

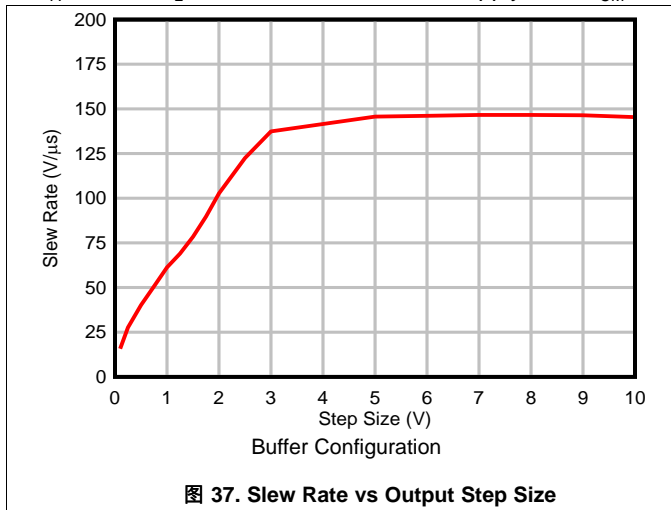

图 39. Intermodulation Distortion

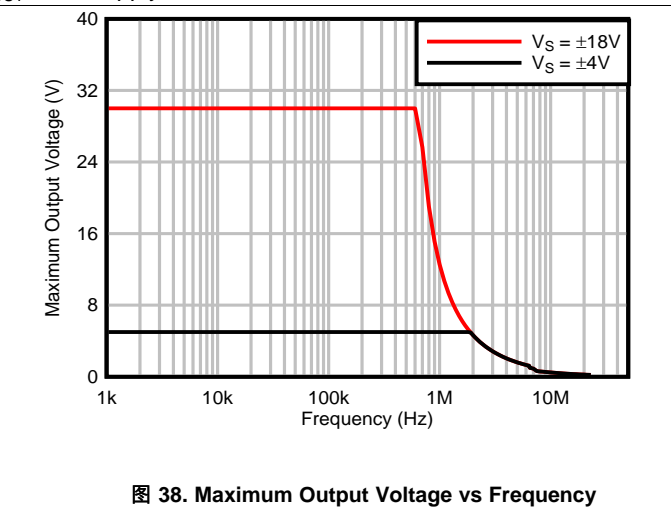

图 40. Electromagnetic Interference Rejection

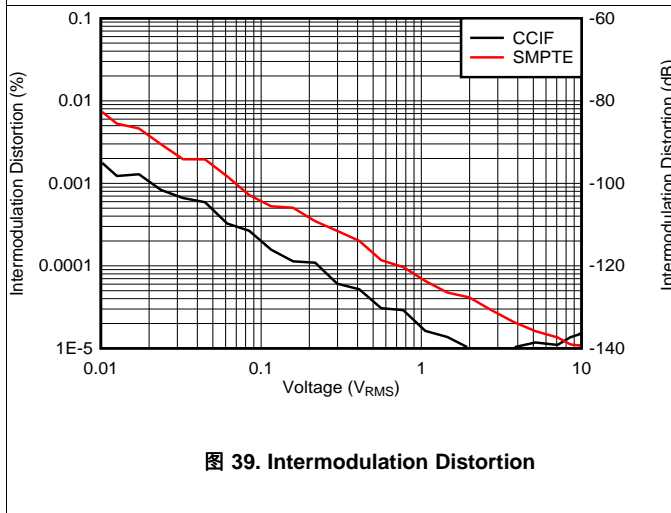

图 41. Harmonic Distortion vs Frequency

7 Detailed Description

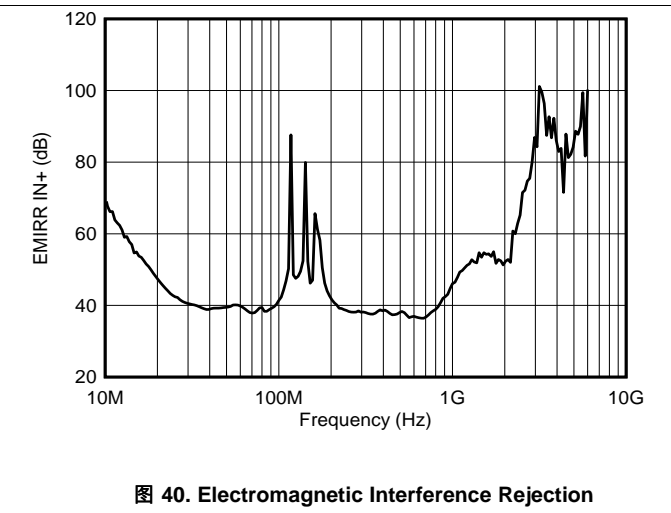
7.1 Overview

The OPA828 is a low-noise, high-speed JFET input amplifier providing the highest levels of precision and accuracy. Each device is laser trimmed in production to ensure the lowest input referred offset voltage. Likewise, input referred offset voltage drift is trimmed and guaranteed over the specified junction temperature range from -40°C to $+125^{\circ}\text{C}$. Additionally each device has its quiescent current laser trimmed to minimize part-to-part variations for dynamic parameters such as input referred noise voltage, gain-bandwidth product, slew rate, and settling time. The combination of low-noise, DC precision, and dynamic performance of the OPA828 is unsurpassed in the industry with the OPA828 taking full advantage of the latest and most advanced high-voltage, SiGe-complementary, JFET/bipolar process technology.

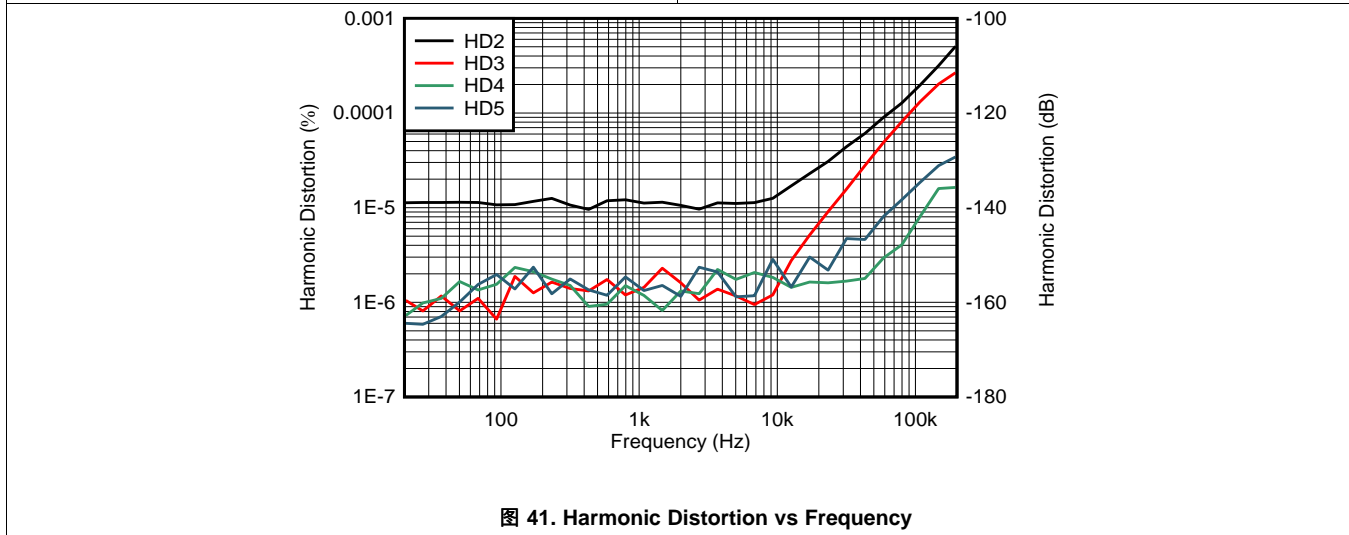
7.2 Functional Block Diagram

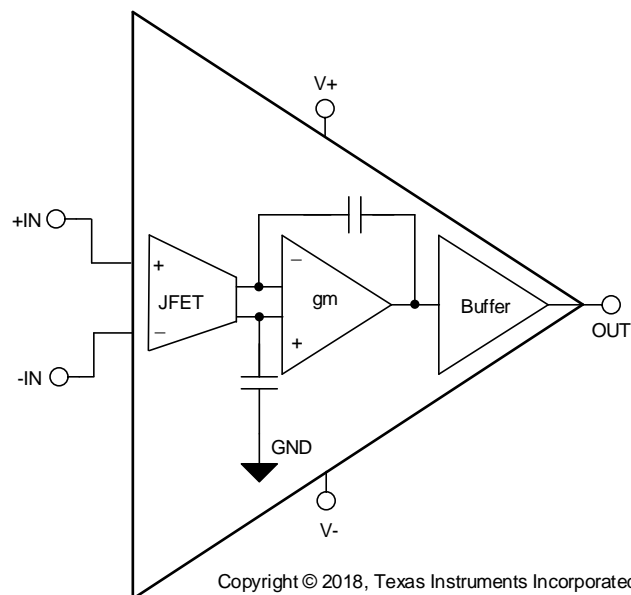

7.3 Feature Description

7.3.1 Operating Characteristics

The OPA828 operational amplifier is specified for operation from 8 V to 36 V (± 4 V to ± 18 V). Many of the specifications apply from -40°C to $+125^{\circ}\text{C}$. Parameters that can exhibit significant variance with regard to operating voltage or temperature are shown in *Typical Characteristics*.

7.3.2 Phase-Reversal Protection

Many operational amplifiers exhibit a phase reversal when the input drives beyond their specified input common-mode range. This condition is most often encountered in non-inverting circuits when the input drives beyond the specified common-mode voltage range, which can cause the output to reverse into the opposite rail. The OPA828 has an internal phase-reversal protection circuitry. The input architecture of the OPA828 prevents phase reversal with input common-mode voltages that exceed the specified maximum and minimum values. The OPA828 output limits to the appropriate rail. This performance is shown in [Figure 42](#). When input voltages can exceed the minimum or maximum specified limits, care must be taken to limit the maximum input current through internal ESD protection diodes.



图 42. No Phase Reversal

7.3.3 Electrical Overstress

The OPA828 is internally protected against ESD events which can occur during manufacturing, handling, or printed-circuit-board assembly. The internal ESD protection diodes are not intended to protect the OPA828 during normal operation when the device is operating under power. The ESD protection circuitry involves several current-steering diodes connected from the input and output pins and routed back to the internal power-supply lines, where the diodes meet at the power-supply ESD cell, an absorption device, internal to the operational amplifier. This protection circuitry is intended to remain inactive during normal circuit operation. In cases where the inputs or output can be driven above the positive power supply or below the negative power supply care must be taken to limit the current through the internal diodes to 10 mA or less. In harsh electrical environments external protection circuitry may be required and is dependant upon the application requirements and environmental conditions.

Feature Description (接下页)

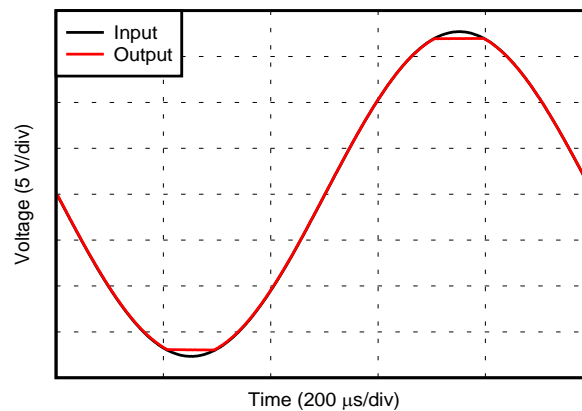
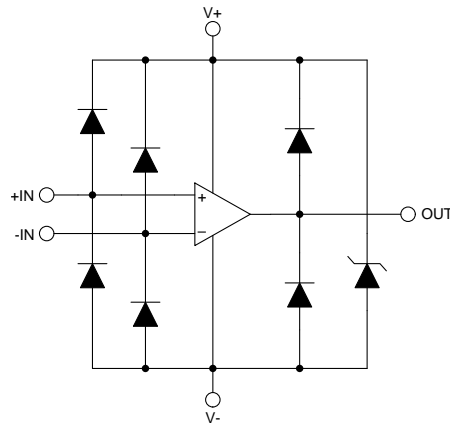

Copyright © 2018, Texas Instruments Incorporated

图 43. Equivalent Internal ESD Circuitry

One example of protecting the OPA828 inputs against an input over-voltage condition is illustrated in [图 44](#). In this example the non-inverting input to the OPA828 is protected with the addition of an external resistor. If the input voltage, V_{IN} , exceeds either power supply voltage, the input ESD diodes become forward biased at approximately 0.5 V. It is recommended to limit the current through the forward-biased internal ESD diodes under such conditions; see [Absolute Maximum Ratings](#). In this specific example illustrated in [图 44](#), the addition of the input resistor provides the necessary current limiting and allows for input voltages at V_{IN} up to ± 25.5 V. Assuming a symmetrical, dual power supply configuration, the maximum input voltage for this circuit configuration can be determined from [公式 1](#):

$$\pm |V_{IN}| = |V_S| + 0.5V + 10mA \times R_{IN} \quad (1)$$

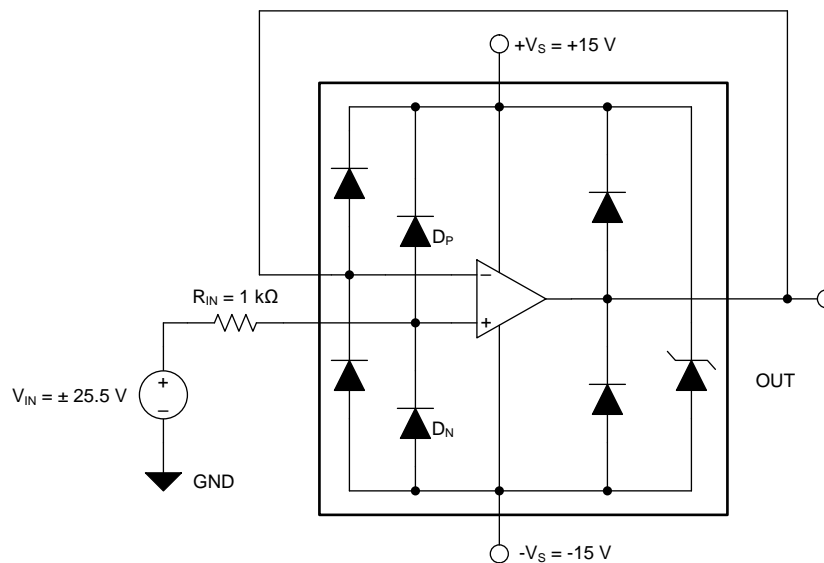

Copyright © 2018, Texas Instruments Incorporated

图 44. Limiting the Input Current

Adding the series input protection resistor as described above will add an additional source of noise to the circuit. Resistance values below 250 Ω contribute less than 10% of additional noise. A resistance value of 1 k Ω increases the noise by approximately by 40%. The OPA828 has an equivalent input noise resistance of approximately 1 k Ω .

Feature Description (接下页)

7.3.4 MUX Friendly Inputs

Multiplexing is a frequently-used technique to perform data acquisition in multi-channel systems with minimal signal-chain requirements. In this context, the role of the multiplexer (MUX) in an acquisition system is to switch between channels and send each signal as fast as possible to a single data converter — maximizing system throughput and minimizing delay. To ensure accurate processing, a precision amplifier is placed downstream from the multiplexer to precisely drive the analog-to-digital converter (ADC). This concept is illustrated in 图 45.

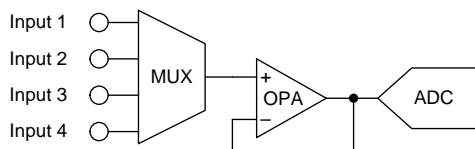

Copyright © 2018, Texas Instruments Incorporated

图 45. Typical Multiplexed System Block Diagram

In a typical multiplexed application it is common that large transient voltages can be presented to the input of the op amp driving the ADC. Large input differential voltages are commonly seen during slewing or open-loop operation, which is especially common when switching from one MUX input to another. Traditional precision amplifiers often consist of a differential transistor pair that is protected from large differential transient input voltages with anti-parallel diodes between the inputs of the amplifier. These anti-parallel diodes are effective at limiting the voltage differential between the inputs to one or two forward diode voltage drops, which protects the precision input devices from damage. However, the anti-parallel diodes do have considerable drawbacks such as large inrush currents when they are turned on. If passive filtering or high source impedance is present, large inrush current can disturb settling time, limiting the throughput of the system and degrading signal-chain precision. The OPA828 does not need anti-parallel diodes to protect the input JFET transistors and is free from large inrush currents even with differential input voltages as large as ± 18 V. These concepts are illustrated in 图 46:

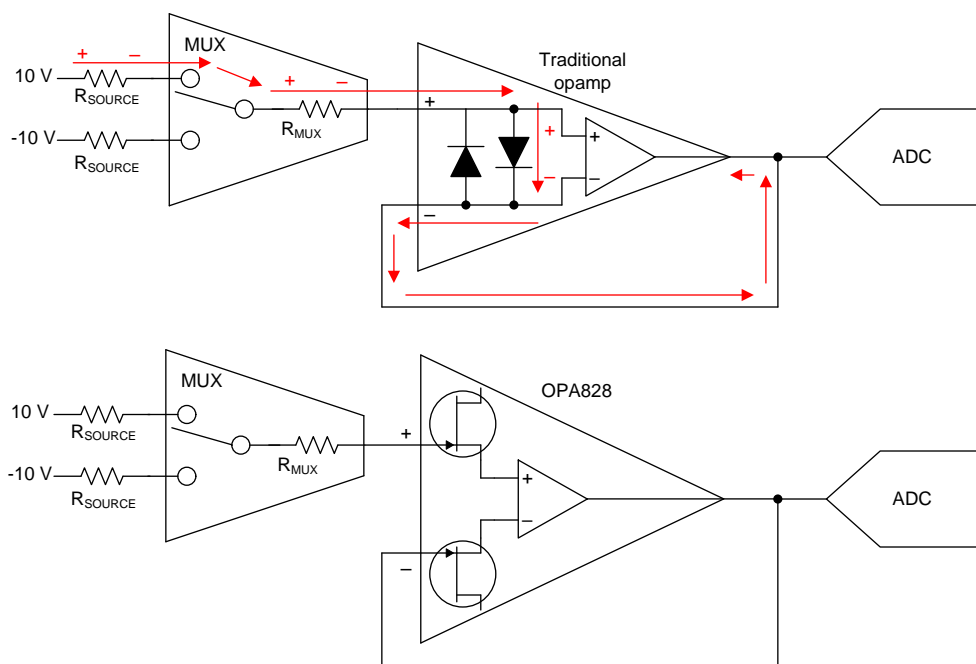

Copyright © 2018, Texas Instruments Incorporated

图 46. Typical Multiplexed System Block Diagram

Feature Description (接下页)

7.3.5 Overload Power Limiter

In many applications, tight limits on opamp power consumption exist and it is therefore highly desirable that the amplifier's power consumption remains constant even during fault conditions, such as a large voltage across the inputs or the output hitting the rail. In particular, high slew-rate amplifiers, such as the OPA828 temporarily increase the supply current when the amplifier is slewing. In slew-boosted amplifiers, the presence of a large input signal can present a specific problem, since it applies a large voltage across the amplifier's inputs. This will activate the slew-boost and can lead to a significant increase in current consumption. In addition, at high supply voltages the large current consumption can lead to significant amplifier self-heating.

OPA828 offers a high slew rate of 150 V/us in combination with a comparably low supply current of 5.5 mA. Like many other amplifiers, this is achieved by a so called slew-boosting method, which temporarily increases the amplifier's current consumption when the amplifier is slewing. Such a slewing condition is detected by measuring the voltage across the input pins. In quiescent condition, this voltage is very small (equal to the amplifier's offset). If, on the other hand, an input voltage is changed rapidly, a large voltage will be applied across the inputs and the amplifier output needs to slew. On OPA828, the supply current increase is gradual and proportional to the applied input voltage, ensuring a well-behaved large step response and excellent THD. Because the high slew rate ensures the output re-settles in less than about 300ns, the increased power consumption is absorbed by the decoupling capacitors, and therefore does not additionally load the power supplies.

In OPA828, such an increase in current consumption is avoided by an additional protection circuit, which continuously monitors both the amplifier's inputs and output. If a large input voltage is detected, the protection circuit checks for the presence of a rapid change in voltage at the output. If the output voltage is not changing, for instance because the output is at a supply rails, the protection circuit will disable the slew-boost circuit after a delay of about 300ns. After the overload condition is removed, the amplifier rapidly recovers to a normal operating condition. This is indicated in [图 47](#), where the amplifiers supply current is measured with its decoupling capacitors removed. It can be observed that after 300 ns, the power consumption of the amplifier goes back to quiescent levels. At the same time, the amplifier still has an excellent overload recovery time of less than 55 ns.



图 47. Supply Current Change with Overloaded Output

7.3.6 Capacitive Load and Stability

[图 48](#) shows the total circuit noise for varying source impedances with the operational amplifier in a unity-gain configuration (with no feedback resistor network and therefore no additional noise contributions). The OPA828 and OPA211 are shown with total circuit noise calculated. The op amp itself contributes both a voltage noise component and a current noise component. The voltage noise is commonly modeled as a time-varying component of the offset voltage. The current noise is modeled as the time-varying component of the input bias current and reacts with the source resistance to create a voltage component of noise. Therefore, the lowest noise

Feature Description (接下页)

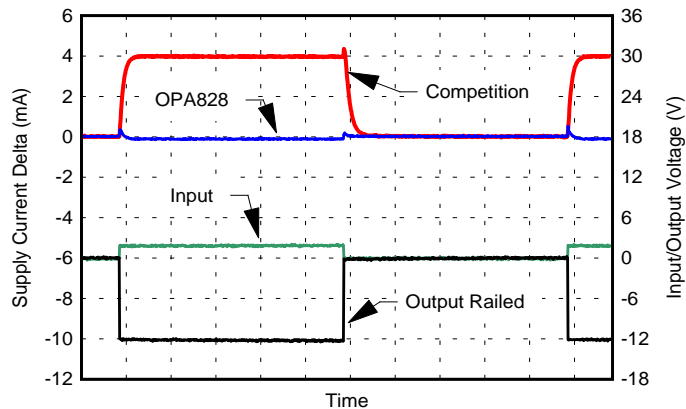
op amp for a given application depends on the source impedance. For low source impedance, current noise is negligible, and voltage noise generally dominates. The OPA828 device has both low voltage noise and extremely low current noise because of the FET input of the op amp. As a result, the current noise contribution of the OPA828 is negligible for any practical source impedance, which makes it the better choice for applications with high source impedance.

The equation in shows the calculation of the total circuit noise, with these parameters:

- e_n = voltage noise
- i_n = current noise
- R_S = source impedance
- k = Boltzmann's constant = 1.38×10^{-23} J/K
- T = temperature in degrees Kelvin (K)



图 48. Noise Performance of the OPA828 and OPA211 in Unity-Gain Buffer Configuration

7.3.7 Capacitive Load and Stability

The dynamic characteristics of the OPA828 are optimized for common operating conditions. The combination of low closed-loop gain and high capacitive loads decreases the phase margin of the amplifier and can lead to gain peaking or oscillations. As a result, heavier capacitive loads must be isolated from the output. The simplest way to achieve this isolation is to add a small resistor (for example, R_{OUT} equal to 50Ω) in series with the output. The 图 49 graph show small-signal overshoot versus capacitive load. See [Feedback Plots Define Op Amp AC Performance](#) for details of analysis techniques and application circuits.

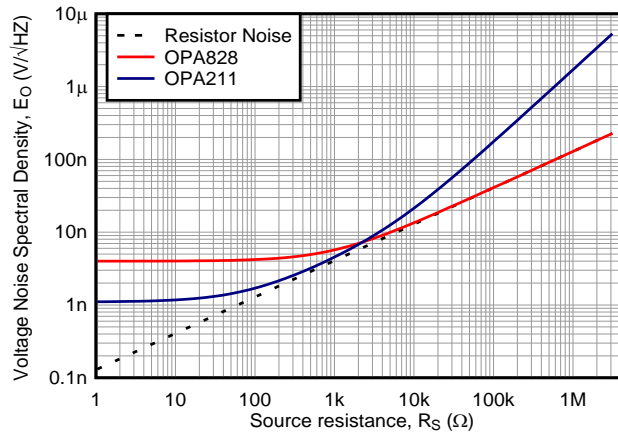

图 49. Small-Signal Overshoot vs Capacitive Load

Feature Description (接下页)

7.3.8 Settling Time

Settling time is a measure of an amplifiers output to settle to within some percentage (error band) of the input amplitude and is used to describe an amplifiers response to a step input. An amplifiers settling time is comprised of both a large signal response and small signal response. The large signal response is characterized by the rise and fall times while the small signal response is characterized by overshoot and ringing. 图 50 illustrates the concepts and terminology associated with an amplifiers settling time. Specifically the settling time is defined as the time it takes the output to settle to within a specified error band from the time the input signal was applied.

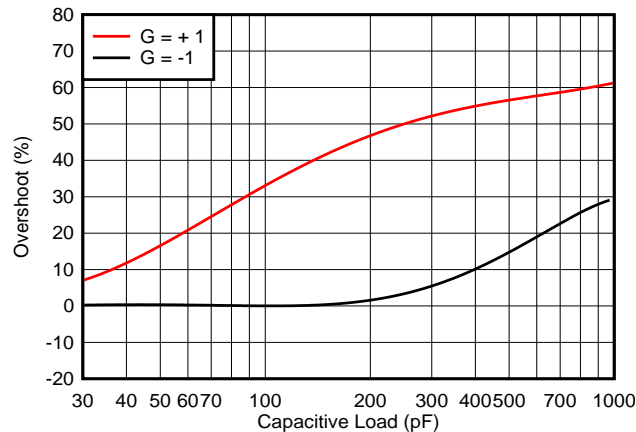

图 50. Settling Time

The OPA828 minimizes settling time for high-resolution systems by incorporating an internal slew boost circuit which minimizes rise and fall times and having wide bandwidth with excellent phase margin with low ringing, enabling small signal settling in minimal time. The OPA828 is trimmed in laser production that will minimize part-to-part variation in the device slew rate, bandwidth and phase margin thus mainlining excellent unit-to-unit variations across all manufacturing lots.

7.3.9 Slew Rate

The parameter of an amplifier that best describes the large signal dynamic behavior is the slew rate. Slew rate is a measure the maximum rate of change of the output voltage with respect to time and is generally expressed in units of volts-per-microsecond, (V/μs). Typically the slew rate is measured as the time it takes for the output to swing from 10% of its final value to 90% of its final value. The slew rate for the signal illustrated in 图 50 is given by 公式 2.

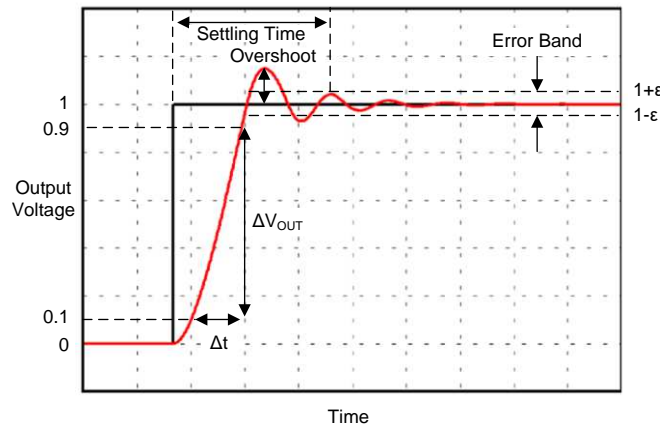
$$Slew\ Rate = \frac{\Delta V_{OUT}}{\Delta t} = \frac{(V_{OUT_{90}} - V_{OUT_{10}})}{(t_{90} - t_{10})} \quad (2)$$

The slew rate of an amplifier is limited by the internal architecture of the amplifier, the amplifiers quiescent power and internal capacitances. The OPA828 maximizes slew rate by incorporating a slew-boost circuit. The proprietary slew boost circuit used in the OPA828 results in a very high slew rate while maintaining low quiescent power levels. The internal slew boost circuit measures the input differential voltage present between +IN and -IN input pins. If this input differential voltage is sufficiently large enough, the internal slew boost circuit increases the internal biasing currents of the amplifier thereby increasing the ability of the output to slew faster. TI recommends placing power supply bypass capacitors close to the OPA828 to make sure of optimum dynamic performance.

Should the inputs of the amplifier have a large static or DC differential voltage present, the OPA828 recognizes that condition, not as an indicator of the need to slew faster, but rather as an overload condition. In this case the OPA828 internal biasing currents do not increase, and the quiescent current remains unchanged from normal operation.

Feature Description (接下页)

7.3.10 Full Power Bandwidth

The full power bandwidth of an amplifier describes the frequency at which the largest sinusoidal signal the amplifier can provide at its output before slew rate induced distortion becomes a dominant source of error. This concept is illustrated in 图 51.



图 51. Slew Rate Induced Distortion

If the inputs of the amplifier are driven too far apart, such as when a multiplexer connected to the inverting input changes channels, a slew boost circuit is enabled to help settling time but can distort the signal. If low distortion is needed, avoid driving the inputs too far apart from each other. The OPA828 has a full power bandwidth of 1.2 MHz with $10 \cdot V_{PEAK}$ output voltage. The maximum output voltage as a function of frequency is illustrated in 图 52.

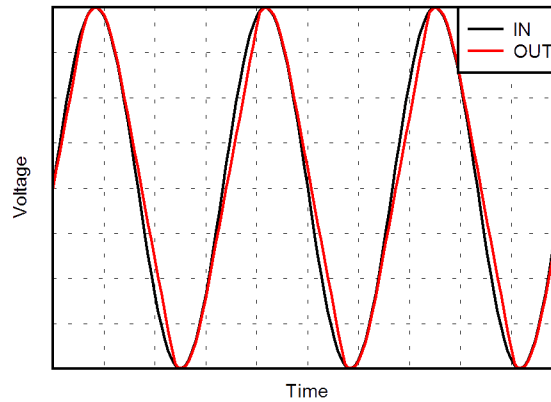

图 52. Maximum Output Voltage vs Frequency

7.3.11 Small Signal Response

The parameters of an amplifier that best describes the small signal dynamic behaviour are the gain-bandwidth product (GBP), unity gain frequency (UGF) and phase margin (PM) of an amplifier. The GBP is a useful parameter to determine the bandwidth of an application in closed loop configurations. 公式 3 can be used to approximate the closed loop bandwidth for the OPA828. Typically the GBP is a specified parameter with the amplifier configured in a non-inverting gain of 100 (40 dB). The GBP of an amplifier is generally assumed to be constant over frequency but in some higher speed amplifiers this is not always the case. The OPA828 has a constant GBP all the way to its UGF, as such the OPA828 open-loop gain has a constant -20 dB/decade slope (-6 dB/octave). The UGF is defined as the frequency at which the gain of the amplifier crosses $1V/V$ (0 dB). 图 53 illustrates the concept of GBP and UGF. The OPA828 has both a GBP and UGF of 45 MHz.

Feature Description (接下页)

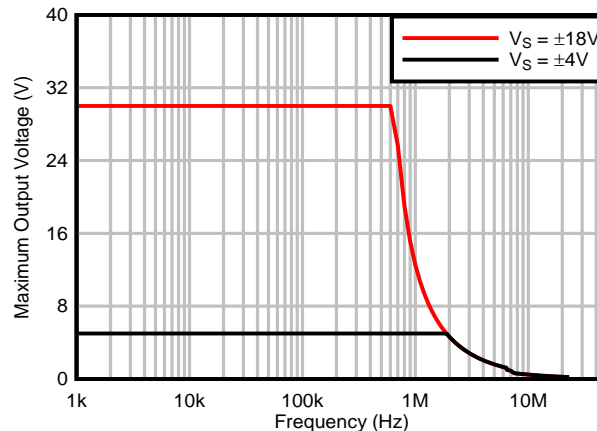
$$\text{Bandwidth} = \frac{GBP}{A_{CL}} = \frac{45\text{MHz}}{A_{CL}} \quad (3)$$



图 53. Gain-Bandwidth Product and Unity Gain Frequency

7.3.12 Thermal Considerations

Through normal operation the OPA828 experiences self-heating, a natural increase in the die junction temperature which occurs in every amplifier. This is a result of several factors including the quiescent power consumption, the package's thermal resistance, PCB layout and the device operating conditions.

To fully ensure the amplifier will operate without entering thermal shutdown it is important to calculate the approximate junction (die) temperature which can be done using 公式 4.

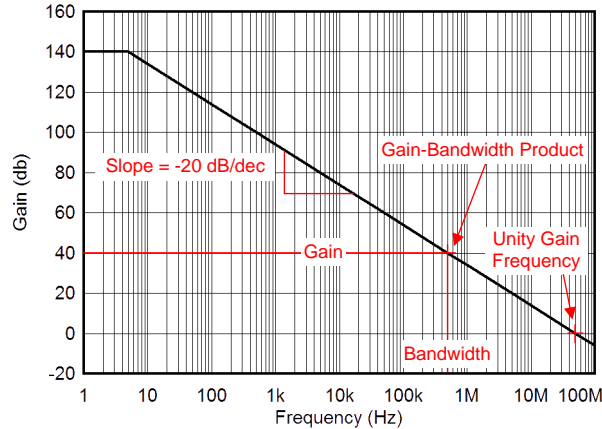
$$T_j = P_D * \Theta_{JA} + T_A \quad (4)$$

公式 5 shows the approximate junction temperature for the OPA828 while unloaded with an ambient temperature of 25°C.

$$T_j = (36V * 5.5mA) * 121.5^\circ C / W + 25^\circ C$$

$$T_j = 49^\circ C \quad (5)$$

For high voltage, high precision amplifiers such as the OPA828 the junction temperature can easily be 10s of degrees higher than the ambient temperature in a quiescent (unloaded) condition. If the device then begins to drive a heavy load the junction temperature may rise and trip the thermal shutdown circuit. The 图 54 shows the maximum output voltage of the OPA828 without entering thermal shutdown vs ambient temperature in both a loaded and unloaded condition.

Feature Description (接下页)



图 54. OPA828 Thermal Safe Operating Area

7.3.13 Thermal Shutdown

The OPA828 is protected from thermal overloads due to an internal thermal shutdown feature. The shutdown design assures thermal protection when operated in demanding, high-temperature industrial environments. The device accurately measures the die junction temperature at the hottest spot on the die. As the junction temperature reaches the thermal shutdown temperature the device is disabled by placing the output into a high impedance state — this prevents further power dissipation by the OPA828 and allows the OPA828 to begin cooling. Once the junction temperature reduces by the thermal hysteresis amount, the OPA828 resumes normal operation. If the output condition that caused the OPA828 to heat up is still present the device may enter thermal shutdown again. The OPA828 quiescent current during shutdown reduces to approximately 20 μ A. Identify the cause of any thermal shutdown, and correct for normal device operation. Thermal shutdown occurs when the OPA828 junction temperature exceeds approximately 165°C. Once in thermal shutdown, the OPA828 returns to normal operation when the junction temperature cools to approximately 145°C.

7.3.14 Low Noise

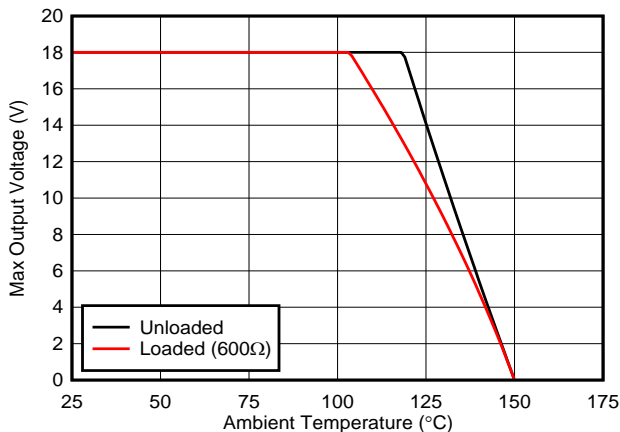
The OPA828 is fabricated on a state-of-the-art SiGe Precision, High-Speed, High-Voltage, BiFET wafer process. Patented wafer processing techniques are used to reduce the noise associated with the JFET gate regions. The OPA828 noise spectral density is shown in 图 55.



图 55. Noise Spectral Density vs Frequency

Feature Description (接下页)

7.3.15 Low Offset Voltage Drift

Each OPA828 is laser trimmed in production. Input offset voltage is trimmed at two temperatures assuring low input offset voltage drift across the full temperature range.

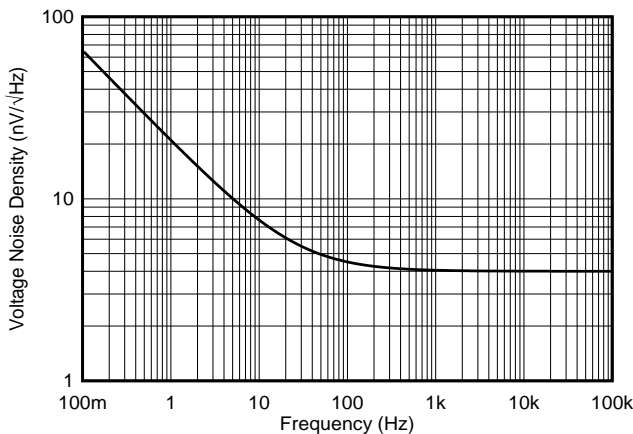

图 56. Input Offset Voltage vs Temperature

7.3.16 Overload Recovery

Overload recovery is defined as the time required for the op amp output to recover from the saturated state to the linear state. The output devices of the op amp enter the saturation region when the output voltage exceeds the rated operating voltage resulting from the high input voltage or the high gain. After the device enters the saturation region, the charge carriers in the output devices must have time to return back to the normal state. After the charge carriers return back to the equilibrium state, the device begins to slew at the normal slew rate. As a result, the propagation delay (in case of an overload condition) is the sum of the overload recovery time and the slew time. The overload recovery time for the OPA828 is approximately 55 ns.

7.4 Device Functional Modes

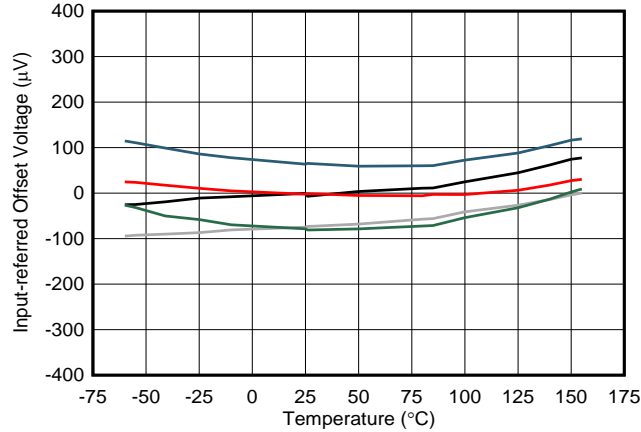
7.4.1 Functional Modes

The OPA828 is operational when the applied power supply voltage is between ± 4 V and ± 18 V. When operating the OPA828 device self-heating occurs. Device self-heating is a function of the power-supply voltage and power delivered to the load. Under heavy loading conditions and elevated ambient temperatures the OPA828 may enter thermal shutdown. Thermal shutdown occurs when the OPA828 junction temperature exceeds approximately 165°C . Once in thermal shutdown, the OPA828 returns to normal operation when the junction temperature cools to approximately 145°C .

8 Application and Implementation

注

Information in the following applications sections is not part of the TI component specification, and TI does not warrant its accuracy or completeness. TI's customers are responsible for determining suitability of components for their purposes. Customers should validate and test their design implementation to confirm system functionality.

8.1 Application Information

The OPA828 combines low offset and offset drift with low noise across a wide bandwidth, making it well suited for a variety of test equipment and data acquisition systems.

8.2 Typical Applications

8.2.1 Typical Application: SAR ADC Driver

The high DC precision and AC performance of the OPA828 along with the 45-MHz bandwidth enable it to quickly and accurately drive a 16-bit successive approximate register (SAR) analog-to-digital converter (ADC).



图 57. OPA828 Configured as a SAR Driver

8.2.1.1 Design Requirements

The design requirements for this example include:

- Power the OPA828 from ± 15 -V power supplies
- Amplifier output must settle to 16-bit accuracy in less than 290 ns
- Gain = $-1/4$
- Amplifier output is biased to 2V
- Amplifier input = ± 10 V, Output = 0 V to 5 V

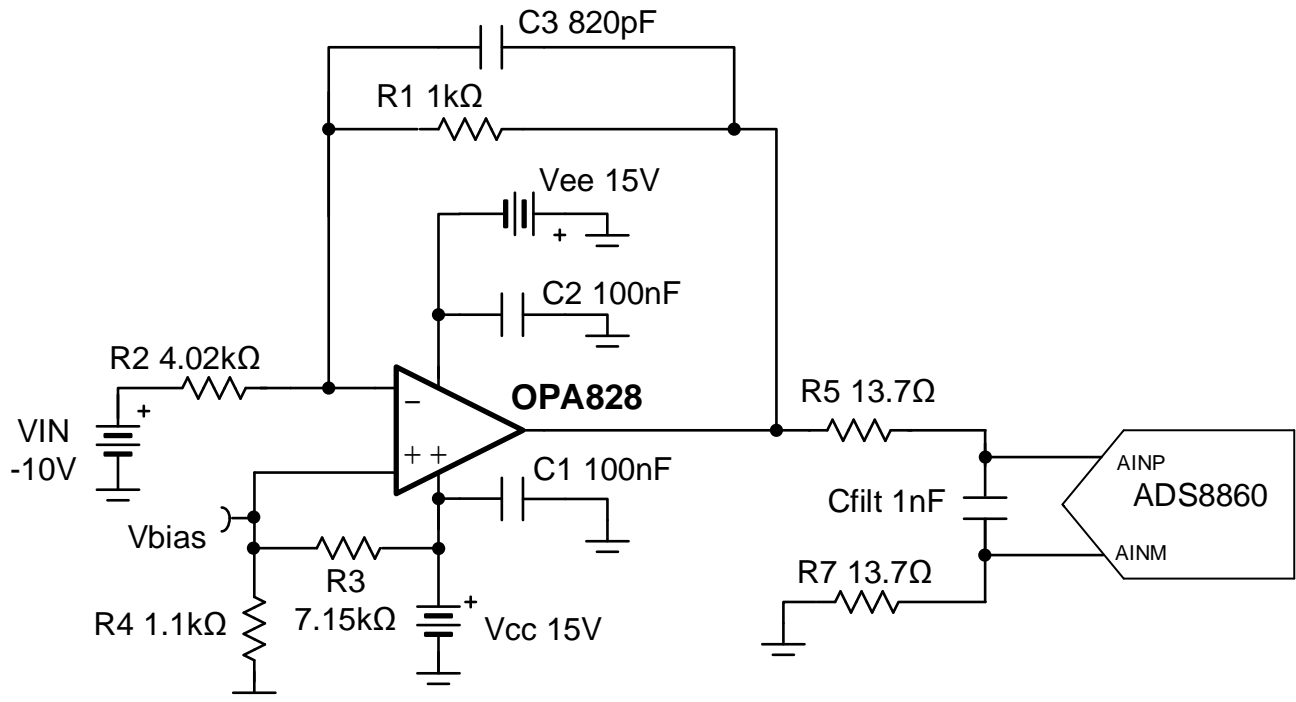
Typical Applications (接下页)

8.2.1.2 Detailed Design Procedure

The OPA828 is configured as shown in to enable a wide input voltage range of ± 10 V to be attenuated to 0 V to 5 V. The output range of the amplifier is selected based on the full scale input range of the ADS8860, a 16-bit, 1 MSPS SAR ADC. Supply rails of ± 15 V are used so the amplifier can achieve linear swing across the full input range. This design allows the amplifier output to settle to 16-bits within the 290-ns acquisition time of the selected ADC.

The [Analog Engineer's Calculator](#) is used to select the resistors and capacitors used to set the signal attenuation as well as the charge bucket between the amplifier and ADC. The input and feedback resistors are chosen to provide a gain of $-1/4$ (for example, a $4\times$ attenuation in an inverting configuration). V_{BIAS} is fixed at 2 V to enable the output to swing from 0 V to 5 V. shows the simulated settling time of this circuit. To function properly the output of the amplifier must settle to within $\pm 1/2$ LSB before the end of the ADC's acquisition cycle. In this example using the OPA8860, the output of the amplifier must settle to within ± 38.15 μ V. V_{error} is the difference between the expected output and the actual output of the amplifier.

An 820 pF capacitor is added to the feedback to create a lowpass filter with a cutoff frequency of 194 kHz. This filter reduces the noise seen by the ADC and improves the accuracy of the system. The DC transfer function of this circuit is shown in [图 59](#) and the AC response in shown in [图 60](#).

See [TI Precision Labs](#) for more details and training on configuring an amplifier for ADC drive, selecting the resistors and capacitor for the charge bucket and other signal chain topics.

8.2.1.3 Application Curves



图 58. OPA828 Output Settling Time



图 59. OPA828 DC Transfer Function

Typical Applications (接下页)

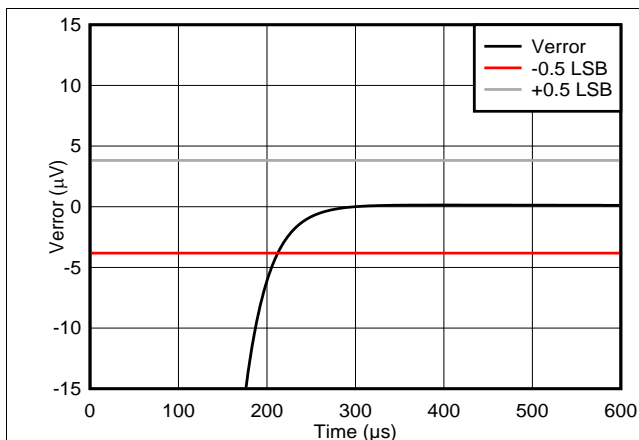

8.2.2 Typical Application: Low-Pass Filter

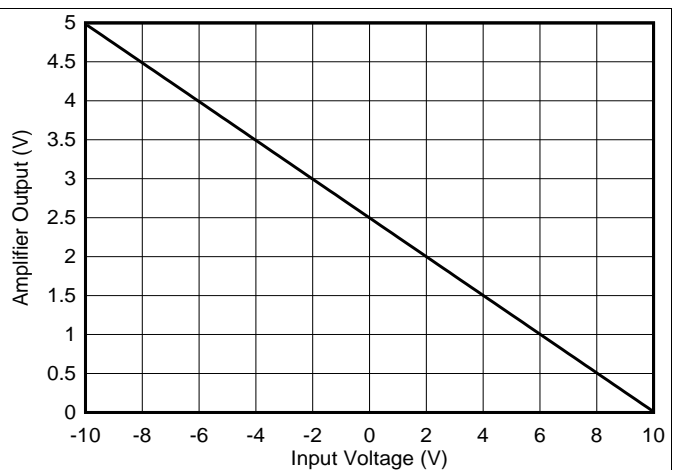
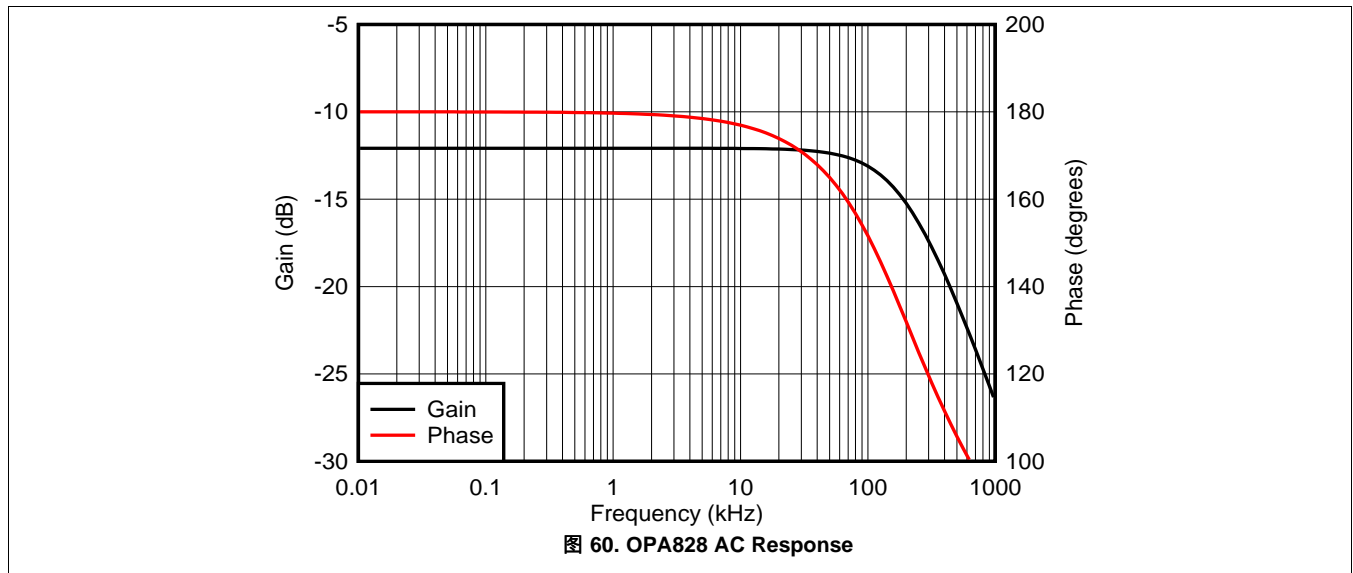
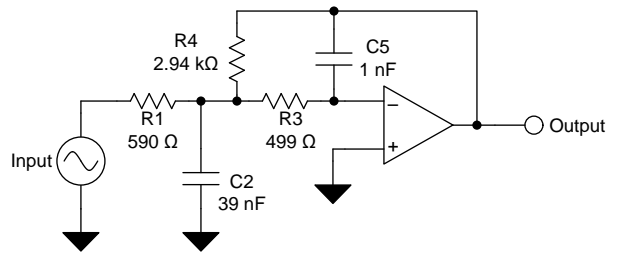

Copyright © 2016, Texas Instruments Incorporated

图 61. Typical OPA828 Application Schematic

8.2.2.1 Design Requirements

Use the following parameters for this design example:

- Gain = 5 V/V (inverting gain)
- Low-pass cutoff frequency = 25 kHz
- Second-order Chebyshev filter response with 3-dB gain peaking in the passband

8.2.2.2 Detailed Design Procedure

The infinite-gain multiple-feedback circuit for a low-pass network function is shown in 图 61. Use 公式 6 to calculate the voltage transfer function.

$$\frac{\text{Output}}{\text{Input}}(s) = \frac{-1/R_1 R_3 C_2 C_5}{s^2 + (s/C_2)(1/R_1 + 1/R_3 + 1/R_4) + 1/R_3 R_4 C_2 C_5} \quad (6)$$

This circuit produces a signal inversion. For this circuit, the gain at dc and the low-pass cutoff frequency are calculated by 公式 7:

$$\text{Gain} = \frac{R_4}{R_1}$$

$$f_c = \frac{1}{2\pi} \sqrt{1/R_3 R_4 C_2 C_5} \quad (7)$$

Typical Applications (接下页)

Software tools are readily available to simplify filter design. [WEBENCH® Filter Designer](#) is a simple, powerful, and easy-to-use active filter design program. The WEBENCH Filter Designer lets designers create optimized filter designs using a selection of TI operational amplifiers and passive components from TI's vendor partners.

Available as a web-based tool from the WEBENCH® Design Center, [WEBENCH® Filter Designer](#) allows to design, optimize, and simulate complete multi-stage active filter solutions within minutes.

8.2.2.3 Application Curve



图 62. Low-Pass Filter Transfer Function

9 Power Supply Recommendations

The OPA828 is specified to operate from 8 V to 36 V (± 4 V to ± 18 V); many specifications apply from -40°C to $+125^{\circ}\text{C}$. Parameters that can exhibit significant variance with regard to operating voltage or temperature are presented in the typical curves.

Place 0.1- μF bypass capacitors close to the power-supply pins to reduce errors coupling in from noisy or highimpedance power supplies. For more detailed information on bypass capacitor placement, refer to the [Layout](#) section.

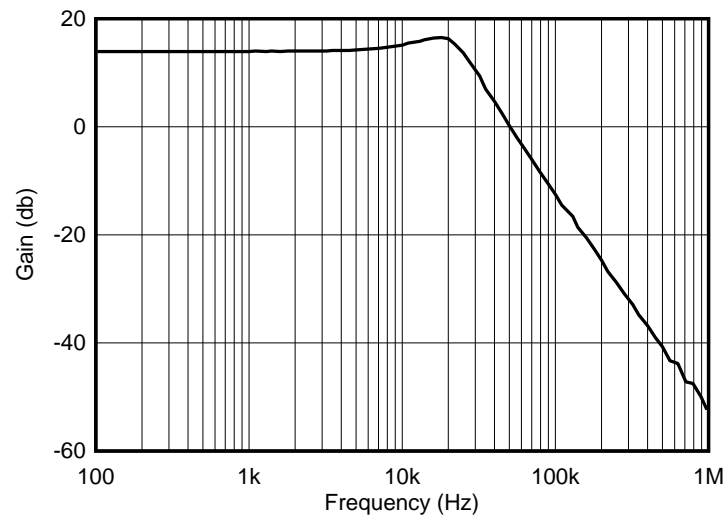
10 Layout

10.1 Layout Guidelines

For best operational performance of the device, use good printed circuit board (PCB) layout practices, including the following guidelines:

- Noise can propagate into analog circuitry through the power pins of the circuit as a whole and op amp itself. Use bypass capacitors to reduce the coupled noise by providing low-impedance power sources local to the analog circuitry.
- Connect low-ESR, 0.1- μ F ceramic bypass capacitors between each supply pin and ground, placed as close as possible to the device. A single bypass capacitor from V+ to ground is applicable for single-supply applications.
- Separate grounding for analog and digital portions of circuitry is one of the simplest and most-effective methods of noise suppression. One or more layers on multilayer PCBs are usually devoted to ground planes. A ground plane helps distribute heat and reduces EMI noise pickup. Make sure to physically separate digital and analog grounds paying attention to the flow of the ground current.
- To reduce parasitic coupling, run the input traces as far away from the supply or output traces as possible. If these traces cannot be kept separate, crossing the sensitive trace perpendicular is much better as opposed to in parallel with the noisy trace.
- Place the external components as close as possible to the device.
- Keep the length of input traces as short as possible. Always remember that the input traces are the most sensitive part of the circuit.
- Consider a driven, low-impedance guard ring around the critical traces. A guard ring can significantly reduce leakage currents from nearby traces that are at different potentials.
- TI recommends cleaning the PCB following board assembly for best performance.
- Any precision integrated circuit may experience performance shifts due to moisture ingress into the plastic package. Following any aqueous PCB cleaning process, baking the PCB assembly is recommended to remove moisture introduced into the device packaging during the cleaning process. A low-temperature, post-cleaning bake at 85°C for 30 minutes is sufficient for most circumstances.

10.2 Layout Example

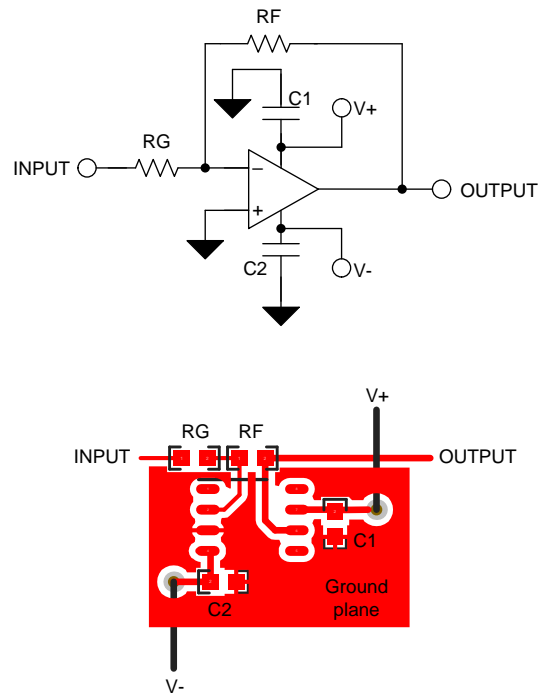

Copyright © 2017, Texas Instruments Incorporated

图 63. OPA828 PCB Example

11 器件和文档支持

11.1 器件支持

11.1.1 开发支持

相关开发支持请参阅以下资源：

[WEBENCH® 滤波器设计器](#)

11.2 文档支持

11.2.1 相关文档

请参阅如下相关文档：

[《用直观方式补偿跨阻放大器》](#)

11.3 接收文档更新通知

要接收文档更新通知，请导航至 [TI.com.cn](#) 上的器件产品文件夹。单击右上角的通知我进行注册，即可每周接收产品信息更改摘要。有关更改的详细信息，请查阅已修订文档中包含的修订历史记录。

11.4 社区资源

下列链接提供到 TI 社区资源的连接。链接的内容由各个分销商“按照原样”提供。这些内容并不构成 TI 技术规范，并且不一定反映 TI 的观点；请参阅 TI 的 [《使用条款》](#)。

TI E2E™ 在线社区 [TI 的工程师对工程师 \(E2E\) 社区](#)。此社区的创建目的在于促进工程师之间的协作。在 [e2e.ti.com](#) 中，您可以咨询问题、分享知识、拓展思路并与同行工程师一道帮助解决问题。

设计支持 [TI 参考设计支持](#) 可帮助您快速查找有帮助的 E2E 论坛、设计支持工具以及技术支持的联系信息。

11.5 商标

E2E is a trademark of Texas Instruments.
All other trademarks are the property of their respective owners.

11.6 静电放电警告



这些装置包含有限的内置 ESD 保护。存储或装卸时，应将导线一起截短或将装置放置于导电泡棉中，以防止 MOS 门极遭受静电损伤。

11.7 术语表

[SLYZ022](#) — TI 术语表。

这份术语表列出并解释术语、缩写和定义。

12 机械、封装和可订购信息

以下页面包含机械、封装和可订购信息。这些信息是指定器件的最新可用数据。数据如有变更，恕不另行通知，且不会对此文档进行修订。如需获取此数据表的浏览器版本，请查阅左侧的导航栏。

重要声明和免责声明

TI 均以“原样”提供技术性数据（包括数据表）、设计资源（包括参考设计）、应用或其他设计建议、网络工具、安全信息和其他资源，不保证其中不含任何瑕疵，且不做任何明示或暗示的担保，包括但不限于对适销性、适合某特定用途或不侵犯任何第三方知识产权的暗示担保。

所述资源可供专业开发人员应用TI 产品进行设计使用。您将对以下行为独自承担全部责任：(1) 针对您的应用选择合适的TI 产品；(2) 设计、验证并测试您的应用；(3) 确保您的应用满足相应标准以及任何其他安全、安保或其他要求。所述资源如有变更，恕不另行通知。TI 对您使用所述资源的授权仅限于开发资源所涉及TI 产品的相关应用。除此之外不得复制或展示所述资源，也不提供其它TI 或任何第三方的知识产权授权许可。如因使用所述资源而产生任何索赔、赔偿、成本、损失及债务等，TI 对此概不负责，并且您须赔偿由此对TI 及其代表造成的损害。

TI 所提供产品均受TI 的销售条款 (<http://www.ti.com.cn/zh-cn/legal/termsofsale.html>) 以及ti.com.cn上或随附TI产品提供的其他可适用条款的约束。TI提供所述资源并不扩展或以其他方式更改TI 针对TI 产品所发布的可适用的担保范围或担保免责声明。

邮寄地址：上海市浦东新区世纪大道 1568 号中建大厦 32 楼，邮政编码：200122
Copyright © 2019 德州仪器半导体技术（上海）有限公司

PACKAGING INFORMATION

Orderable Device	Status (1)	Package Type	Package Drawing	Pins	Package Qty	Eco Plan (2)	Lead/Ball Finish (6)	MSL Peak Temp (3)	Op Temp (°C)	Device Marking (4/5)	Samples
OPA828ID	ACTIVE	SOIC	D	8	75	Green (RoHS & no Sb/Br)	NIPDAU	Level-2-260C-1 YEAR	-40 to 125	OPA828	Samples
OPA828IDR	ACTIVE	SOIC	D	8	2500	Green (RoHS & no Sb/Br)	NIPDAU	Level-2-260C-1 YEAR	-40 to 125	OPA828	Samples

(1) The marketing status values are defined as follows:

ACTIVE: Product device recommended for new designs.

LIFEBUY: TI has announced that the device will be discontinued, and a lifetime-buy period is in effect.

NRND: Not recommended for new designs. Device is in production to support existing customers, but TI does not recommend using this part in a new design.

PREVIEW: Device has been announced but is not in production. Samples may or may not be available.

OBSELETE: TI has discontinued the production of the device.

(2) **RoHS:** TI defines "RoHS" to mean semiconductor products that are compliant with the current EU RoHS requirements for all 10 RoHS substances, including the requirement that RoHS substance do not exceed 0.1% by weight in homogeneous materials. Where designed to be soldered at high temperatures, "RoHS" products are suitable for use in specified lead-free processes. TI may reference these types of products as "Pb-Free".

RoHS Exempt: TI defines "RoHS Exempt" to mean products that contain lead but are compliant with EU RoHS pursuant to a specific EU RoHS exemption.

Green: TI defines "Green" to mean the content of Chlorine (Cl) and Bromine (Br) based flame retardants meet JS709B low halogen requirements of <=1000ppm threshold. Antimony trioxide based flame retardants must also meet the <=1000ppm threshold requirement.

(3) MSL, Peak Temp. - The Moisture Sensitivity Level rating according to the JEDEC industry standard classifications, and peak solder temperature.

(4) There may be additional marking, which relates to the logo, the lot trace code information, or the environmental category on the device.

(5) Multiple Device Markings will be inside parentheses. Only one Device Marking contained in parentheses and separated by a "~" will appear on a device. If a line is indented then it is a continuation of the previous line and the two combined represent the entire Device Marking for that device.

(6) Lead/Ball Finish - Orderable Devices may have multiple material finish options. Finish options are separated by a vertical ruled line. Lead/Ball Finish values may wrap to two lines if the finish value exceeds the maximum column width.

Important Information and Disclaimer:The information provided on this page represents TI's knowledge and belief as of the date that it is provided. TI bases its knowledge and belief on information provided by third parties, and makes no representation or warranty as to the accuracy of such information. Efforts are underway to better integrate information from third parties. TI has taken and continues to take reasonable steps to provide representative and accurate information but may not have conducted destructive testing or chemical analysis on incoming materials and chemicals. TI and TI suppliers consider certain information to be proprietary, and thus CAS numbers and other limited information may not be available for release.

In no event shall TI's liability arising out of such information exceed the total purchase price of the TI part(s) at issue in this document sold by TI to Customer on an annual basis.

TAPE AND REEL INFORMATION



QUADRANT ASSIGNMENTS FOR PIN 1 ORIENTATION IN TAPE



*All dimensions are nominal

Device	Package Type	Package Drawing	Pins	SPQ	Reel Diameter (mm)	Reel Width W1 (mm)	A0 (mm)	B0 (mm)	K0 (mm)	P1 (mm)	W (mm)	Pin1 Quadrant
OPA828IDR	SOIC	D	8	2500	330.0	12.4	6.4	5.2	2.1	8.0	12.0	Q1

TAPE AND REEL BOX DIMENSIONS



*All dimensions are nominal

Device	Package Type	Package Drawing	Pins	SPQ	Length (mm)	Width (mm)	Height (mm)
OPA828IDR	SOIC	D	8	2500	367.0	367.0	35.0



D0008A

PACKAGE OUTLINE

SOIC - 1.75 mm max height

SMALL OUTLINE INTEGRATED CIRCUIT



4214825/C 02/2019

NOTES:

- Linear dimensions are in inches [millimeters]. Dimensions in parenthesis are for reference only. Controlling dimensions are in inches. Dimensioning and tolerancing per ASME Y14.5M.
- This drawing is subject to change without notice.
- This dimension does not include mold flash, protrusions, or gate burrs. Mold flash, protrusions, or gate burrs shall not exceed $.006$ [0.15] per side.
- This dimension does not include interlead flash.
- Reference JEDEC registration MS-012, variation AA.

EXAMPLE BOARD LAYOUT

D0008A

SOIC - 1.75 mm max height

SMALL OUTLINE INTEGRATED CIRCUIT



LAND PATTERN EXAMPLE
EXPOSED METAL SHOWN
SCALE:8X



SOLDER MASK DETAILS

4214825/C 02/2019

NOTES: (continued)

- 6. Publication IPC-7351 may have alternate designs.
- 7. Solder mask tolerances between and around signal pads can vary based on board fabrication site.

EXAMPLE STENCIL DESIGN

D0008A

SOIC - 1.75 mm max height

SMALL OUTLINE INTEGRATED CIRCUIT



SOLDER PASTE EXAMPLE
BASED ON .005 INCH [0.125 MM] THICK STENCIL
SCALE:8X

4214825/C 02/2019

NOTES: (continued)

8. Laser cutting apertures with trapezoidal walls and rounded corners may offer better paste release. IPC-7525 may have alternate design recommendations.
9. Board assembly site may have different recommendations for stencil design.

重要声明和免责声明

TI 均以“原样”提供技术性及其可靠性数据（包括数据表）、设计资源（包括参考设计）、应用或其他设计建议、网络工具、安全信息和其他资源，不保证其中不含任何瑕疵，且不做任何明示或暗示的担保，包括但不限于对适销性、适合某特定用途或不侵犯任何第三方知识产权的暗示担保。

所述资源可供专业开发人员应用TI 产品进行设计使用。您将对以下行为独自承担全部责任：(1) 针对您的应用选择合适的TI 产品；(2) 设计、验证并测试您的应用；(3) 确保您的应用满足相应标准以及任何其他安全、安保或其他要求。所述资源如有变更，恕不另行通知。TI 对您使用所述资源的授权仅限于开发资源所涉及TI 产品的相关应用。除此之外不得复制或展示所述资源，也不提供其它TI 或任何第三方的知识产权授权许可。如因使用所述资源而产生任何索赔、赔偿、成本、损失及债务等，TI 对此概不负责，并且您须赔偿由此对TI 及其代表造成的损害。

TI 所提供产品均受TI 的销售条款 (<http://www.ti.com.cn/zh-cn/legal/termsofsale.html>) 以及ti.com.cn上或随附TI产品提供的其他可适用条款的约束。TI提供所述资源并不扩展或以其他方式更改TI 针对TI 产品所发布的可适用的担保范围或担保免责声明。

邮寄地址：上海市浦东新区世纪大道 1568 号中建大厦 32 楼，邮政编码：200122

Copyright © 2020 德州仪器半导体技术（上海）有限公司